

Piston Seals

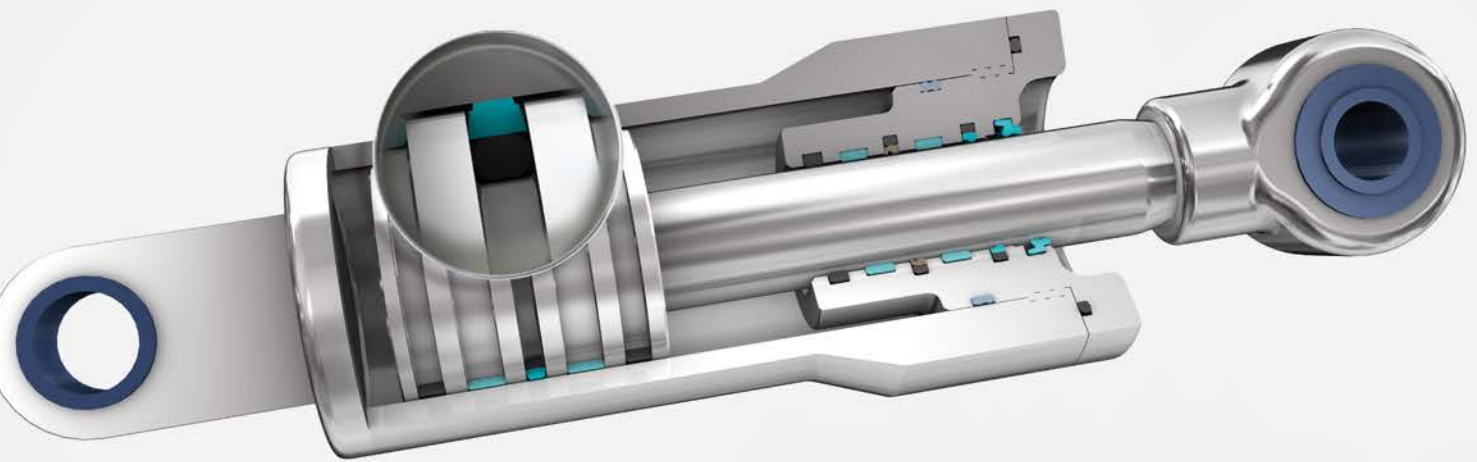

! This page is intentionally left blank.

Contents

240	Choice of the Sealing Element	353	Turcon® Variseal® M2
245	Design Instructions	363	Turcon® VL Seal®
247	Installation of Piston Seals	373	Zurcon® U-Cup PUA
253	Turcon® Glyd Ring®	379	Zurcon® Wynseal
263	Turcon® Glyd Ring® T	385	Zurcon® Wynseal M
273	Turcon® Glyd Ring® Hz	395	POLYPAC® - PHD/P
283	Zurcon® Glyd Ring® D	401	Compact Seal POLYPAC® - Duopac DPS/DPC
289	Zurcon® Glyd Ring® P	409	POLYPAC® - Veepac CH
295	Turcon® AQ-Seal® 5	415	POLYPAC® - Veepac CH/G1
305	Turcon® AQ-Seal®	419	POLYPAC® - Selemaster DSM
315	Turcon® Stepseal® 2K	425	Additional Seals
325	Turcon® Stepseal® V		
335	Turcon® Stepseal® V LM		
345	Turcon® Double Delta®		

■ Choice of the Sealing Element

Sealing elements have a decisive influence on the design, function and service life of hydraulic and pneumatic cylinders and systems.

This applies equally to the piston seals where leak tightness, resistance to wear and gap extrusion, resistance to process media, resistance to high and low temperatures, low friction, compact form and simple installation are demanded in order to meet the requirements of industry for a functional sealing solution.

Trelleborg Sealing Solutions has developed a complete range of seals which, due to their optimized geometries, designs and use of high-quality materials such as Turcon® and Zurcon®, satisfy the technical and economic demands of the industry.

In order to select the most appropriate seal type and material, it is necessary to first define all the desired functional parameters. Table 75 can then be used to make an initial selection of seals according to the specific requirements of the application.

The second column of the table contains the number of the page on which further general information together with specific design and installation instructions on the particular seal type and materials (or material combinations with multi-element seals, e.g. Turcon® Glyd Ring® T) can be found.

Furthermore on page 246, attention is drawn to the quality of the mating surface. We recommend that the limits specified there be observed, as they have a decisive influence on the functionality and service life of the system.

The final choice of seal type and material must also take account of the detailed information on the seal elements.

Please do not hesitate to contact your local Customer Solution Center for further information on specific applications and special technical questions.

NOTE ON ORDERING

All multi-element standard piston seals, e.g. Glyd Ring® T, are generally supplied as complete seal sets. The set includes the seal and matching elastomer energizing elements. The O-Ring does not have to be ordered separately. It is also possible to use other O-Ring materials from our O-Ring catalog. In this case, please order the seal ring and O-Ring separately. We will inform you the sizes of the O-Ring on request.







When ordering the seal ring separately, it is then not necessary to mention the "O-Ring material code" in the TSS Article No. shown in the ordering examples.

Older designs of seals no longer contained in this catalog naturally continue to be available (see chapter "Additional Seals"). For all new applications, however, we recommend the use of the seal types and preferred sizes (ISO series, wherever possible) listed in this catalog.

Other combinations of Turcon® materials and special designs can be developed and supplied for special applications in all sizes up to 2,700 mm diameter, provided there is sufficient demand.

The sizes contained in this catalog are generally available from stock or can be supplied at short notice. We reserve the right to modify our supply programme.







Table 75: Selection Criteria for Piston Seals

Seal		Application	Standard	Action	Size Range	Technical Data*			Recommended Seal Material			
Type	Page					Field of Application	Temp. Range**	Speed		Pressure		
		Light	Media	Heavy	ISO	Single	Double	mm	°C	m/s	MPa max.	
Turcon® Glyd Ring® 	253	Mobile hydraulics	•	•	•	7425-1	X	8 - 2,700	-45/ +200	15	50	M12
		Machine tools	•	•	•						50	T46
		Injection molding machines	•	•	•			20	T05			
		Presses	•	•	•			8 - 2,300	-45/ +110	2	60	Z53
Turcon® Glyd Ring® T 	263	Mobile hydraulics	•	•	•	7425-1	X	8 - 2,700	-45/ +200	15	40	M12
		Standard cylinders	•	•	•						50	T46
		Machine tools	•	•	•			8 - 2,300	-45/ +110	2	60	Z53
		Injection molding machines	•	•	•						Automotive industry	•
Turcon® Glyd Ring® Hz 	273	Machine tools	•	•	7425-1	X	X	8 - 999	-45/ +200	15	30	M12
		Handling machinery	•	•							25	T40
		Servo equipment	•	•							-45/ +80	2
Zurcon® Glyd Ring® D 	283	Earthmoving Equipment	•	•	7425-1 3320	X	30 - 250	-30/ +110	0.5	40	Z13	
Mobile hydraulics	•	•										
Zurcon® Glyd Ring® P 	289	Earthmoving Equipment	•	•	7425-1 3320	X	45 - 200	-30/ +110	1	50	Z66 + NBR	
		Mobile hydraulics	•	•								
		Construction Machinery	•	•								
Turcon® AQ-Seal® 5 	295	Mobile hydraulics	•	•	-	X	40 - 700	-45/ +200	3	50	M12	
		Holding cylinders	•	•						50	T46	
		Piston accumulators	•	•								







* The data below are maximum values and cannot be used at the same time.
The maximum pressure depends on temperature and gap dimension.

** Temperature range depends on choice of elastomer material and media.
In the case of Turcon® piston seals in unpressurized applications in temperatures below 0 °C,
please contact your local Customer Solution Center for assistance!

Table continues on next page

Seal		Application	Standard	Action	Size Range	Technical Data*			Recommended Seal Material			
Type	Page					Field of Application	Temp. Range**	Speed		Pressure		
		Light	Media	Heavy	ISO	Single	Double	mm	°C	m/s	MPa max.	
Turcon® AQ-Seal® 	305	Standard cylinders	•	•	7425-1		X	15 - 700	-45/ +200	2	40	M12
		Piston accumulators	•	•							40	T46
Turcon® Stepseal® 2K 	315	Mobile hydraulics	•	•	7425-1		X	8 - 2,700	-45/ +200	15	50	M12
		Standard cylinders	•	•							50	T46
		Machine tools	•	•				8 - 2,300	-45/ +110	2	60	Z53
		Injection molding machines	•	•								
Presses	•	•										
Turcon® Stepseal® V 	325	Mobile hydraulics	•	•	7425-1		X	15 - 2,700	-45/ +200	15	50	M12
		Machine tools	•	•							50	T46
		Injection molding machines	•	•								
Presses	•	•										
Turcon® Stepseal® V LM 	335	Mobile hydraulics	•	•	7425-1		X	15 - 2,700	45/ +200	15	50	M12
		Wind turbines	•	•							50	T46
		Injection molding machines	•	•								
Presses	•	•										
Turcon® Double Delta® 	345	Machine tools	•	•	3601/ 3771		X	5 - 2,700	-45/ +200	15	20	T05
		Handling devices/ manipulators	•	•	35						M12	
		Valves	•	•	AS4716						35	T46
		Chemical industry	•	•								
Turcon® Variseal® M2 	353	High and low temperatures	•	•	3771		X	6 - 2,500	-70/ +300	15	40	T40
		Aggressive media	•	•	AS4716			6 - 2,700			20	T05
		Foodstuffs	•	•								

* The data below are maximum values and cannot be used at the same time.
 The maximum pressure depends on temperature and gap dimension.
 ** Temperature range depends on choice of elastomer material and media.
 In the case of Turcon® piston seals in unpressurized applications in temperatures below 0 °C,
 please contact your local Customer Solution Center for assistance!

Seal		Application			Standard	Action	Size Range	Technical Data*			Recommended Seal Material	
Type	Page	Field of Application						ISO	Single	Double		Temp. Range**
			Light	Media	Heavy				°C	m/s	MPa max.	
Turcon® VL Seal® 	363	Machine tools	•	•	•	3601/ 3771	X	10 - 2,700	-45/ +200	15	50	M12
		Automotive industry	•	•	•						AS4716	10 - 2,300
		Handling devices / manipulators	•	•	•							
Zurcon® U-Cup PUA 	373	Presses Lift platforms	•	•	•	-	X	14 - 250	-35/ +110	0.5	40	Z20
Zurcon® Wynseal 	379	Standard cylinders Mobile hydraulics	•	•		7425-1	X	12 - 300	-35/ +110	0.5	25	Z20
Zurcon® Wynseal M 	385	Standard cylinders	•	•		7425-1	X	8 - 2,300	-45/ +110	0.5	25	Z54
		Mobile hydraulics	•	•							45	Z53
		Handling machinery Agriculture	•	•							8 - 2,700	-45/ +200
Compact Seal PHD/P 	395	Mobile hydraulics Excavators Heavy duty hydraulic cylinders	•	•	•	-	X	50 - 180	-35/ +110	0.5	35	Z20 + NBR + POM
Duopac DPS / DPC 	401	Mining equipment Presses Steel mills Water hydraulics	•	•	•	-	X	40 - 250	-30/ +130	0.5	40	Fabric rein- forced NBR + POM



* The data below are maximum values and cannot be used at the same time.

The maximum pressure depends on temperature and gap dimension.

** Temperature range depends on choice of elastomer material and media.

In the case of Turcon® piston seals in unpressurized applications in temperatures below 0 °C, please contact your local Customer Solution Center for assistance!

Table continues on next page

Seal		Application			Standard	Action		Size Range	Technical Data*			Recommended Seal Material	
Type	Page	Field of Application	Light	Media		Heavy	ISO		Single	Double	mm		Temp. Range**
										°C	m/s	MPa max.	
Veepac CH 	409	Presses	•	•	•	-	X		20 - 545	-30/ +130	0.5	40	Fabric reinforced Rubber + POM
		Steel mills	•	•	•								
		Ship hydraulics	•	•	•								
		Scrape shears	•	•	•								
		Civil engineering	•	•	•								
		Continuous casting	•	•	•								
		Special hydraulic cylinders	•	•	•								
		Water locks	•	•	•								
Veepac CH/G1 	415	Mining equipment	•	•	•	-	X		40 - 250	-30/ +200	0.5	40	Fabric reinforced Rubber
		Excavators	•	•	•								
		Steel mills	•	•	•								
		Presses	•	•	•								
Selemaster DSM 	419	Mining equipment	•	•	•	-		X	45 - 360	-30/ +130	0.5	70	Fabric reinforced Rubber + POM
		Excavators	•	•	•								
		Steel mills	•	•	•								
		Presses	•	•	•								

* The data below are maximum values and cannot be used at the same time.
 The maximum pressure depends on temperature and gap dimension.
 ** Temperature range depends on choice of elastomer material and media.
 In the case of Turcon® piston seals in unpressurized applications in temperatures below 0 °C, please contact your local Customer Solution Center for assistance!

■ Design Instructions

LEAD-IN CHAMFERS

Piston seals are always fitted with an interference fit. In order to avoid damage during installation, lead-in chamfers and rounded edges must be provided on the cylinder barrel, see Figure 93. If this is not possible for design reasons, a separate installation tool must be used.

The minimum length of the lead-in chamfer Z_{min} depends on the profile size of the seal and can be seen from the following tables.

Generally Z_{min} , from Table 76, Table 77 and Table 78 is recommended, but at 15° Z must also exceed 2.5% of the bore diameter D_N . At 20° Z is calculated correspondingly.

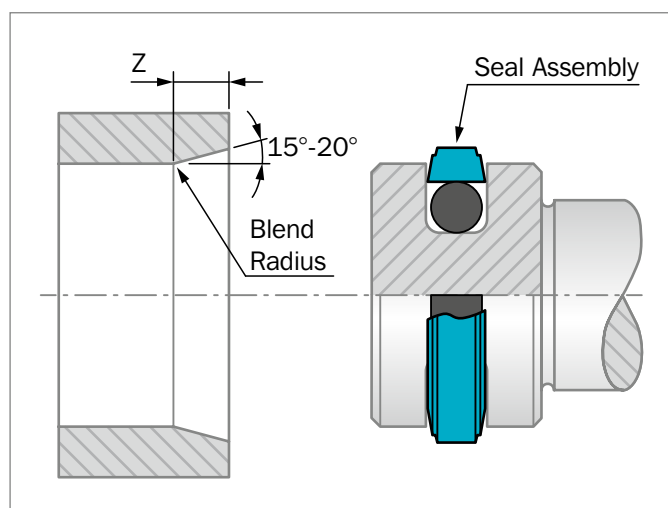

Figure 93: Lead-in chamfer

Table 76: Elastomer Energized Seals

Minimum chamfer for a calibrated seal.

Groove Width L_1^*	Lead-in Chamfer Length Z_{min}	
	15°	20°
2.2	2.5	2.0
3.2	3.0	2.5
4.2	3.5	3.0
6.3	5.0	4.0
8.1	6.5	5.0
9.5	7.5	5.5
13.8	10.5	8.0

* The groove width can be found in table "Installation Dimensions" for Turcon® Glyd Ring®, Glyd Ring® T, Glyd Ring® Hz, AQ-Seal® Stepseal® 2K, Stepseal® V and Zurcon® Wynseal M.

Table 77: Compact Seal and Variseal®

Minimum for a calibrated seal (Variseal)

Compact Seal Groove Depth*	Variseal® M2 Series	Lead-in Chamfer Length Z_{min}	
		15°	20°
3.5		2.5	1.5
4.0		2.5	1.5
5.0		3.0	2.0
7.5	PVA0	4.5	3.0
10.0	PVA1 / PVA2	5.0	4.0
12.5		6.5	6.0
15.0	PVA3	7.5	6.5
20.0		10.0	8.5
	PVA4	12.0	9.0
	PVA5	17.0	13.0

* The groove depth is calculated as $(D_N - D_1)/2$. The dimensions for D_N and d_1 can be found in the tables "Installation Dimensions", from chapter Compact Seal Duopac DPS/DPC.

Table 78: Double Delta®

Minimum chamfer for a calibrated seal.

O-Ring Cross Section** d_2		Lead-in Chamfer* Length Z_{min}	
		15°	20°
1.78	-	2.5	2.0
2.40	2.62	3.0	2.5
3.00	3.53	3.5	3.0
5.33	5.70	5.0	4.0
7.00	-	6.5	5.0
8.40	-	7.5	5.5

* Though not less than 2.5% of bore diameter.

** The O-Ring cross-section d_2 can be found in the appropriate table "Installation Dimensions", from chapter Double Delta®.

For Turcon® seals which have been expanded over a piston the seal must be calibrated with a separate calibration sleeve, or the cylinder tube, where the inlet chamfer is minimum 2 x the value from Table 76 Elastomer Energized Seals.

SURFACE ROUGHNESS ISO 4287

The functional reliability and service life of a sealing system is dependent upon the quality and surface finish of the mating surface to be sealed.

Scores, scratches, pores, concentric or spiral machining marks are not permitted. Higher demands must be made on the surface finish of dynamic mating surfaces than of static mating surfaces.

The characteristics most frequently used to describe the surface micro-finish R_a , R_z and R_{max} are defined in ISO 4287-1. These characteristics alone, however, are not sufficient for assessing the suitability in seal technology. In addition the material contact area of the surface roughness profile R_{mr} in accordance with ISO 4287-1 should be demanded. The significance of this surface specification is illustrated in Figure 94. It shows clearly that specification of R_a and R_z does not describe the surface roughness profile accurately enough. The material contact area R_{mr} is essential to assess surface suitability, as the specific profile form determines this parameter. This in turn is directly dependent on the machining process employed.

Trelleborg Sealing Solutions recommends that the following surface finishes be observed:

Table 79: Surface Roughness

Parameter	Surface Roughness μm		
	Mating Surface		Groove Surface
	Turcon® Materials	Zurcon® and Rubber	
R_{max}	0.63 - 2.50	1.00 - 4.00	< 16.0
R_z	0.40 - 1.60	0.63 - 2.50	< 10.0
R_a	0.05 - 0.20	0.10 - 0.40	< 1.6

The material contact area R_{mr} should be approximately 50 to 70%, determined at a cut depth $c = 0.25 \times R_z$, relative to a reference line of C_{ref} . 5%.



Surface profile	R_a	R_z	R_{mr}
closed profile form 	0.1	1.0	70%
open profile form 	0.2	1.0	15%

Figure 94: Profile forms of surfaces

Figure 94 shows two surface profiles, both of which exhibit nearly the same value for R_z in the test procedure. The difference becomes obvious when the material contact areas of the surface profiles are compared. These show that the upper roughness profile with $R_{mr} = 70\%$ has the better seal to mating surface ratio.

■ Installation of Piston Seals

GENERAL INSTALLATION INSTRUCTIONS

The following points should be observed before installation of the seals:

- Ensure the cylinder tube has a lead-in chamfer; if not, use a calibration sleeve, see Figure 100.
- Deburr and chamfer, or round sharp edges, cover the tips of screw threads
- Remove machining residues such as chips, dirt and other foreign particles, and carefully clean all parts
- The seals can be installed more easily if they are greased or oiled. Attention must be paid to the compatibility of the seal materials with these lubricants. Use only grease without solid additives (e.g. molybdenum disulphide or zinc sulphide).
- Do not use tools with sharp edges.

INSTALLATION IN SPLIT GROOVES

Installation in split grooves is straight forward. The sequence of installation corresponds to the configuration of the seal. Individual seal elements must not be allowed to twist. During final installation of the piston into the cylinder, elastomer or spring-preloaded seals must be calibrated. The corresponding cylinder barrel can be used for this purpose, provided it has a long lead-in chamfer. Alternatively, a calibration sleeve should be used.

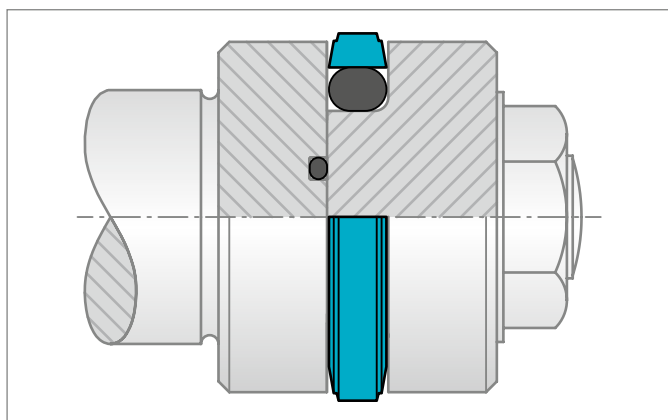

Figure 95: Installation in a split groove

INSTALLATION IN CLOSED GROOVES

- Without installation tools

Observing the instructions in the chapter "General installation instructions", closed groove installation of elastomer seals as Compact Seal and Zurcon® Wynseal is performed by expanding the seal ring over the piston.

For Turcon® and Zurcon® elastomer energized seals, the use of installation tool is recommended. If installation has to be performed without installation tools, the following points should be observed:

- Place the O-Ring in the groove and expand the seal ring over the piston, see Figure 96. Turcon® seals can be installed more easily by heating in oil, water or using a hot air fan to approximately 80 °C to 100 °C (expanding and then shrinking back to the original form).
- Use no sharp edged tools to expand the seal rings. Sizing of the seal ring is achieved with a separate calibration sleeve, or with the cylinder tube provided this has lead-in chamfers equivalent to 2 x the values from Table 76.

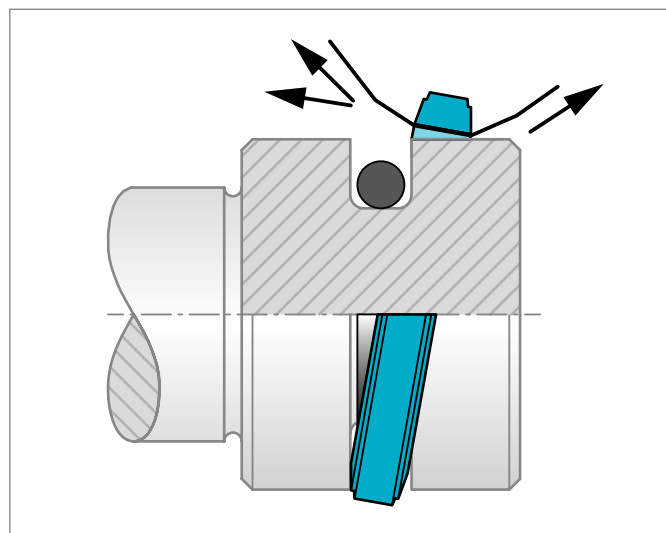

Figure 96: Fitting the seal ring onto the O-Ring in the groove

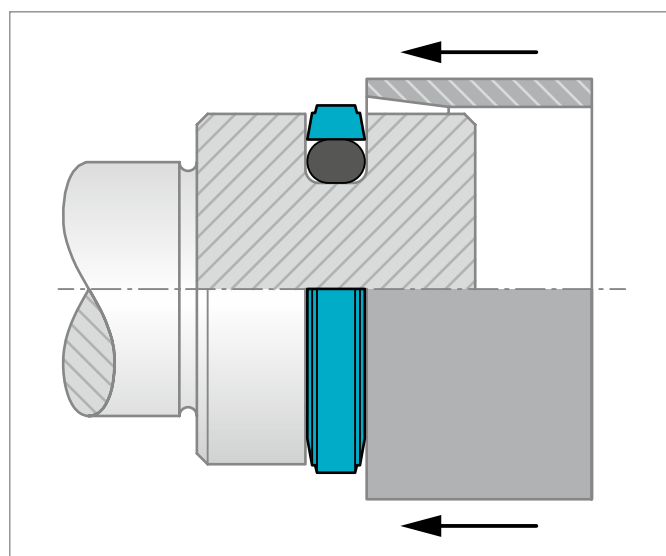

Figure 97: Calibration of the installed seal

INSTALLATION IN CLOSED GROOVES

- With installation aids

Use of a three-piece installation tool is recommended for the series production installation of Turcon® and Zurcon® seal elements. The tool consists of:

- Installation cone
- Expanding pusher
- Calibration sleeve

All these parts should be made of a polymer material (e.g. Acetal, POM) with good sliding characteristics and low abrasiveness to avoid damage to the seals.

Due to the wide range of sizes and application-specific installation conditions, installation tools cannot be standardized. Custom-designed assembly aids and equipment are available through the ServicePLUS Installation Tools Service. Contact your local Customer Solution Center for more information.

The sequence of installation is illustrated in Figure 98 to Figure 100. Note, however, that the installation of Turcon® seal elements should be performed quickly in order to ensure optimum recovery of the seal ring.

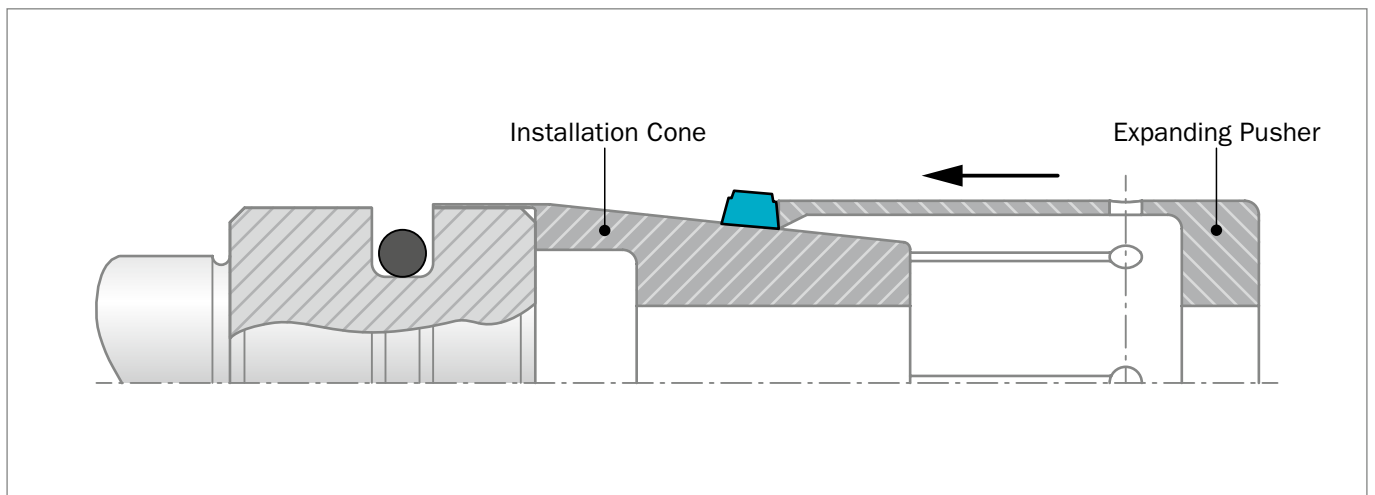

Figure 98: Expanding the Turcon® or Zurcon® sealing element using an expanding sleeve over the installation cone

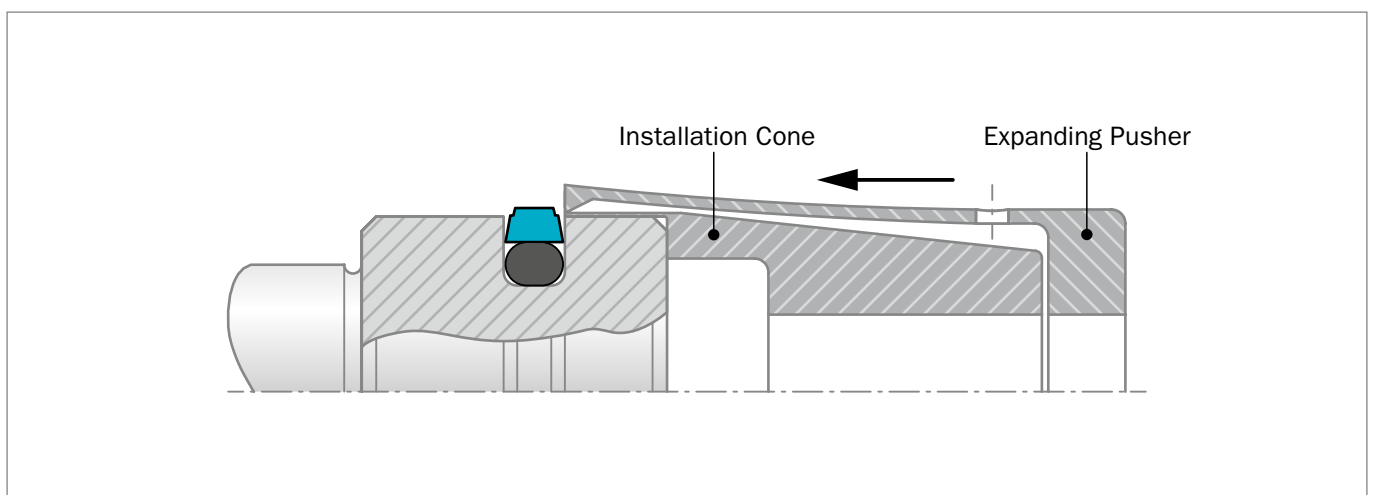

Figure 99: Sealing element after snapping into the groove

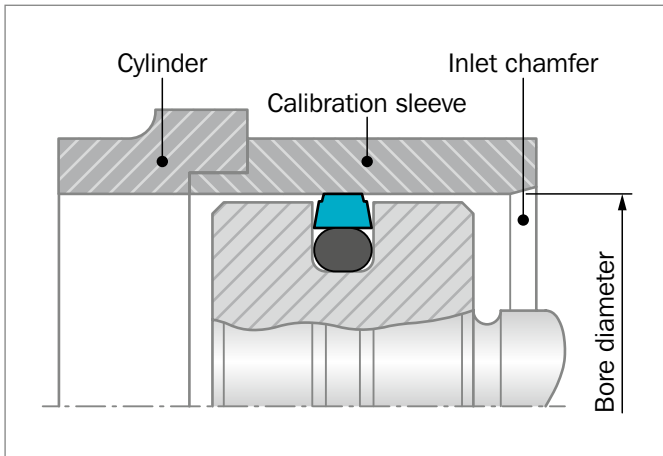

Figure 100: Sizing the sealing element with calibration sleeve

Table 80: Closed groove installation for Turcon® piston seals

Glyd Ring® and seals for similar groove sizes can be installed in closed grooves above the following piston diameters:

O-Ring Series	Material M12, T05, T29, T40, T46	Material M04, T08, T10, Z54	Material Z53, Z80
	D _N mm	D _N mm	D _N mm
000	≥ 8	≥ 15	≥ 20
100	≥ 15	≥ 20	≥ 35
200	≥ 25	≥ 35	≥ 60
300	≥ 40	≥ 50	≥ 75
400	≥ 60	≥ 80	≥ 110
400 H	≥ 133	≥ 133	≥ 150
8.4*	≥ 250	≥ 250	≥ 250
12.0**	≥ 400	≥ 400	≥ 400

* O-Ring cross section according to SMS 1586.

**The energizer can have a special shape.

INSTALLATION OF TURCON® DOUBLE DELTA®

Installation in closed grooves is possible from 8 mm bore diameter. For diameters smaller than 50 mm a installation cone - see Figure 101 - is recommended. After installation the seal must be calibrated, this may be done with the lead-in chamfer of the cylinder tube or by means of a separate calibration sleeve.

Turcon® piston seals can be installed more easily by heating to approximately 80 °C to 100 °C (expanding and then shrinking back to the original form).

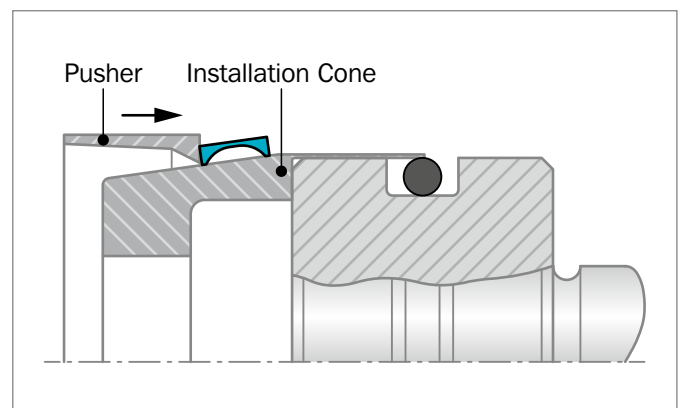

Figure 101: Installation of Turcon® Double Delta® in closed groove with extended Installation cone

INSTALLATION FOR TURCON® VL SEAL®

Installation in closed grooves is possible for diameters according to Table 81.

The O-Ring is inserted in the groove and located at the side of the groove, where after the seal is pushed over the installation cone and into the groove, note the difference in design of the expanding pusher and the installation cone depending on direction of installation - see Figure 102. After insertion in the groove the seal is preferably calibrated before the piston is inserted in the cylinder.

- Turcon® piston seals can be installed more easily by heating to approximately 80 °C to 100 °C (expanding and then shrinking back to the original form).

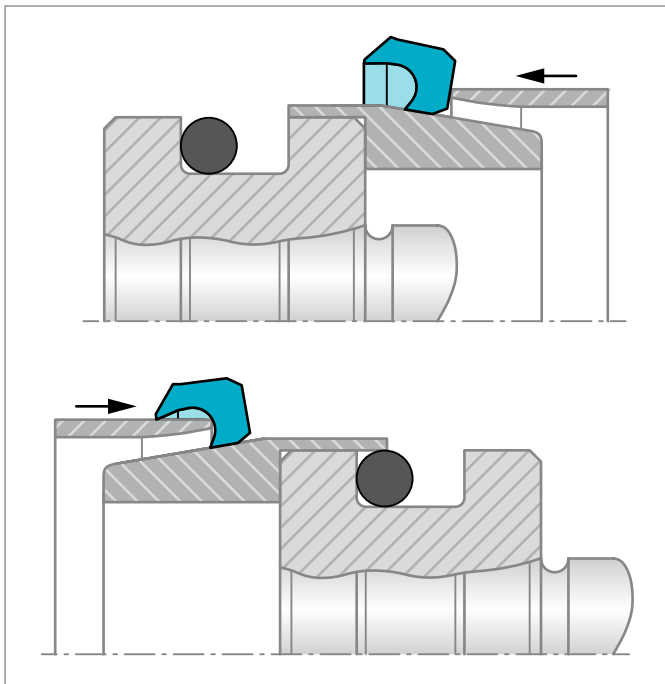

Figure 102: Installation of Piston VL Seal® in closed groove

Table 81: Closed groove installation for VL Seal®

Series No.	Material M12, T05, T29, T40, T46	Material M04, T08, T10, Z54	Material Z53, Z80,
	D _N mm	D _N mm	D _N mm
PEL1	≥ 20	≥ 30	≥ 50
PEL2	≥ 40	≥ 50	≥ 75
PEL3	≥ 60	≥ 100	≥ 110
PEL4	≥ 125	≥ 135	≥ 150
PEL5	≥ 200	≥ 200	≥ 200
PEL6	≥ 400	≥ 400	≥ 400

INSTALLATION OF SPRING ENERGIZED SEALS

Turcon® Variseal® seals should preferably be installed in split grooves. Installation in half-open grooves is possible with a snap fitting. Figure 103 shows the design of the groove.

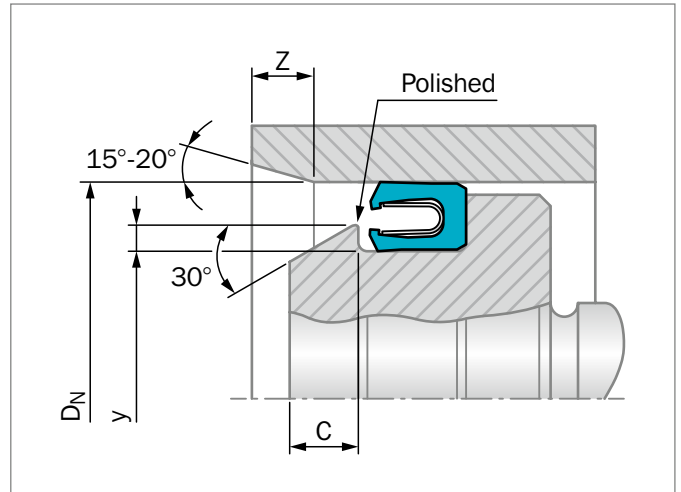

Figure 103: Installation in a half-open groove

Table 82: Installation in Half-Open Grooves

Series No.	D _N min.	Y min.	Z min.	C min.
PVA0	11.0	0.4	1.20	0.70
PVA1	17.5	0.6	1.50	1.10
PVA2	20.0	0.7	2.50	1.25
PVA3	28.0	0.8	4.50	1.40
PVA4	45.0	0.9	6.00	1.60
PVA5	100.0	1.5	11.00	2.60

For further details, see chapter Turcon® Variseal®.

In exceptional cases or with existing designs, an installation in closed grooves is also possible. The details in Table 82 should be regarded as guide values for installation.

Table 83: Installation in closed grooves

Series No.	D _N mm
PVA0	35
PVA1	50
PVA2	70
PVA3	105
PVA4	140
PVA5	250

INSTALLATION OF THE COMPACT SEAL

The Compact Seal can be installed in one-piece or split pistons. On one-piece pistons, the inner rubber-elastic sealing element is first installed in the middle of the groove diameter by expanding over the piston. Then the cut Back-up Ring are fitted on both sides of the sealing element and then the two cut guide rings are installed.

On split pistons the individual parts are installed in the following order: Guide ring, Back-up Ring, sealing element, Back-up Ring, Guide ring.

Before installation all seal parts, including piston and cylinder, should be oiled or greased.

INSTALLATION OF AQ-SEAL® AND AQ-SEAL® 5 WITH QUAD-RING® OR BEAN SEAL

The same installation procedure for piston Glyd Ring® may be used for AQ-Seal® and AQ-Seal® 5 see pages 247 to 249 except for AQ-Seal® 5, which uses different groove sizes. However, the Quad-Ring® or Bean Seal should not be fitted until AQ-Seal® or AQ-Seal® 5 have been calibrated - see Figure 100.

INSTALLATION HINT:

AQ-Seal® and AQ-Seal® 5 with Quad-Ring® or Bean Seal are normally supplied with the Quad-Ring® or Bean Seal uninstalled:

To assist mounting of the elastomer element after AQ-Seal® or AQ-Seal® 5 have been calibrated; dental floss could be helpful to avoid twisting of the Quad-Ring® or Bean Seal - see Figure 104.

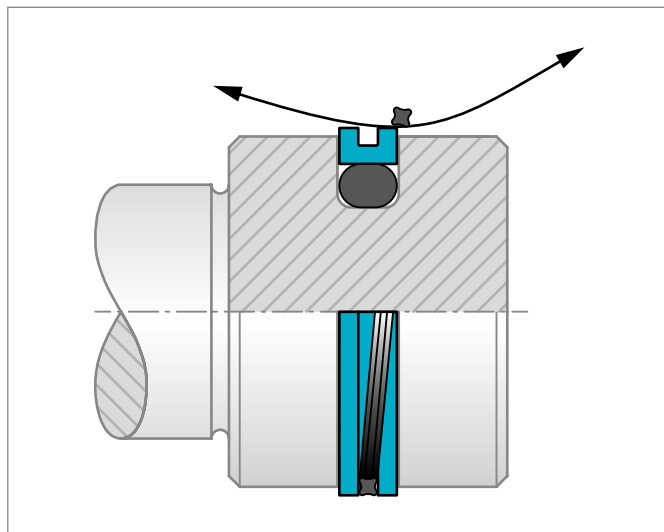

Figure 104: Installation of Quad-Ring® in AQ-Seal® for piston.

! This page is intentionally left blank.

Turcon® Glyd Ring®



Double-acting

Rubber-energized plastic-faced seal

Material:

Turcon®, Zurcon® and Elastomer

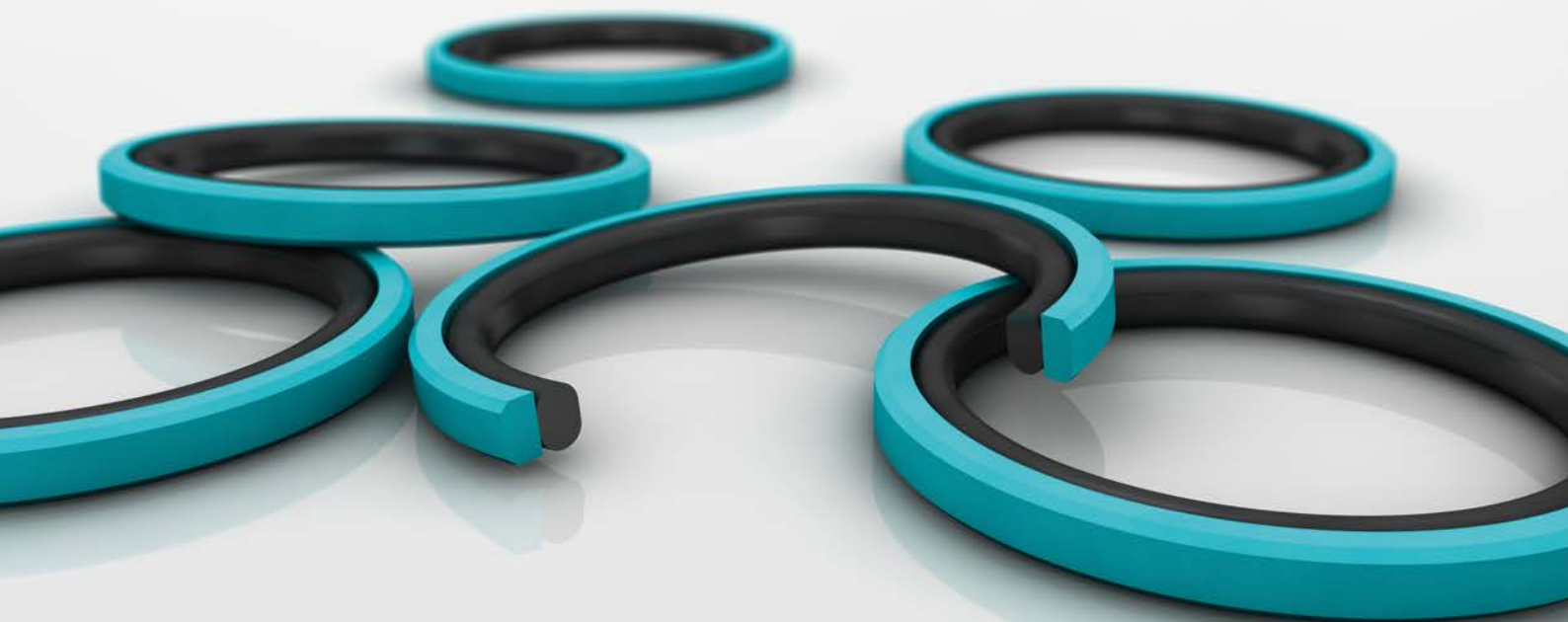

! This page is intentionally left blank.



Turcon® Glyd Ring®



Description

Turcon® Glyd Ring® is a very effective and reliable low friction seal. It is particularly suitable as a piston seal in both high and low pressure systems.

The double-acting Glyd Ring® is a combination of a Turcon® based slipper seal and an energizing O-Ring. It has an interference fit which together with the squeeze of the O-Ring ensures a good sealing effect even at low pressure. At higher system pressures, the O-Ring is energised by the fluid, pushing Glyd Ring® against the sealing face with increased force.

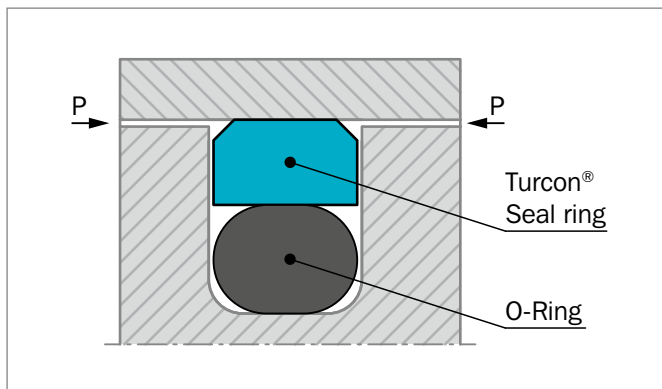

Figure 105: Turcon® Glyd Ring®

The geometry of Glyd Ring® ensures good static sealing and allows the lubricating hydrodynamic fluid film to be built under the seal in linear applications.

ADVANTAGES

- No stick-slip effect when starting for smooth operation
- Minimum static and dynamic friction for a minimum energy loss and operating temperature
- Suitable for non lubricating fluids depending on seal material for optimum design flexibility
- High wear resistance ensures long service life
- Installation grooves acc. to ISO 7425-1 as well as Stepseal® standard groove dimensions
- No adhesive effect to the mating surface during long period of inactivity or storage
- Suitable for most hydraulic fluids in relation with most modern hardware materials and surface finish depending on material selected.
- Suitable for environmentally friendly hydraulic fluids
- Available for all cylinder diameters up to 2,700 mm.

APPLICATION EXAMPLES

Over several decades Glyd Ring® has been successfully implemented in a large variety of applications as double acting Piston seals in hydraulic components such as:

- Injection molding machines
- Machine tools
- Presses
- Excavators
- Forklifts & handling machinery
- Agriculture equipment
- Valves for hydraulic & pneumatic circuits
- Servo equipment
- Pressure intensifiers
- Jacks

OPERATING CONDITIONS

Glyd Ring® is recommended for linear (with a length of stroke at least twice the groove width) and helical movements.

Pressure:	Up to 60 MPa
Speed:	Up to 15 m/s
Frequency:	Up to 5 Hz.
Temperature:	-45 °C to +200 °C* depending on O-Ring material
Media:	Mineral oil-based hydraulic fluids, flame retardant hydraulic fluids, environmentally friendly hydraulic fluids (bio-oils), phosphate ester, water and others, depending on the seal and O-Ring material compatibility see Table 84
Clearance:	The maximum permissible radial clearance S_{max} is shown in the Table 85 as a function of the operating pressure and functional diameter.

IMPORTANT NOTE

The above data are maximum values and cannot be used at the same time, e.g. the maximum operating speed depends on material type, pressure, temperature and gap value. Temperature range also depends on media.

* In the case of unpressurized applications in temperatures below 0 °C please contact your local Customer Solution Center for more information!



NOTCHES

To assure that a rapid energising of the seal takes place at sudden changes of pressure and direction of motion, radial notches are made on both sides of the seal.

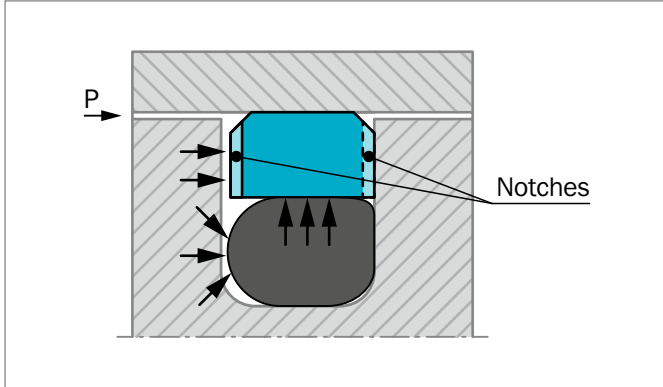

Figure 106: Turcon® Glyd Ring® with notches

Notches are standard on the following series and diameters
 PG 42 for bore dia. > 30 mm
 PG 44 for bore dia. > 20 mm
 PG 46 for bore dia. > 40 mm

INSTALLATION INSTRUCTIONS

Glyd Ring® is installed according to information on page 247 to 249.

Closed groove installation according to dimensions in Table 80 page 249.

RECOMMENDED MATERIALS

The following material combinations have proven effective for hydraulic applications:

Turcon® Glyd Ring® in Turcon® M12

All round material for light to heavy hydraulic applications with linear or helical movements in mineral oils, flame retardant hydraulic fluids, phosphate ester, bio-oils or fluids having low lubricating properties:

O-Ring:	NBR 70 Shore A	N
	FKM 70 Shore A	V

Set code: M12N or M12V

Turcon® Glyd Ring® in Turcon® T46

For medium to heavy applications with linear movements in mineral oils and other medium with good lubrication:

O-Ring:	NBR 70 Shore A	N
	FKM 70 Shore A	V

Set code: T46N or T46V

For specific applications, all Turcon® materials are available. Other material combinations are listed in Table 84.

**Table 84: Turcon® and Zurcon® Materials for Glyd Ring®**

Material, Applications, Properties	Code	O-Ring Material Shore A	Code	O-Ring Operating Temp. * °C	Mating Surface Material	MPa max. Dynamic
Turcon® M12 First material choice for seals in linear motion Overall improved properties For new constructions and updating For all commonly applied hydraulic fluids including fluids with low lubrication performance Lowest friction and best sliding properties Lowest wear on seals Improved absorption of abrasive contaminants Low wear or abrasion of counter surface BAM tested Mineral fiber and Additives filled Color: Dark gray	M12	NBR 70	N	-30 to +100	Steel	50
		NBR 70 Low temp.	T	-45 to +80	Steel hardened	
		FKM 70	V	-10 to +200	Cast iron Stainless steel Titanium	
Turcon® T05 For lubricating fluids Also for gas service Very low friction Very good sliding and sealing properties Color: Turquoise	T05	NBR 70	N	-30 to +100	Steel	20
		NBR 70 Low temp.	T	-45 to +80	Steel hardened	
		FKM 70	V	-10 to +200		
Turcon® T08 For lubricating fluids and linear motion Very high compressive strength and extrusion resistance Hard counter surfaces is recommended Bronze filled Color: Light to dark brown, which may have variations in shading	T08	NBR 70	N	-30 to +100	Steel hardened	60
		NBR 70 Low temp.	T	-45 to +80	Cast iron	
		FKM 70	V	-10 to +200		
Turcon® T10 For hydraulic and pneumatic For lubricating and non-lubricating fluids High extrusion resistance Good chemical resistance Not for electrically conducting fluids BAM tested Carbon, graphite filled Color: Black	T10	NBR 70	N	-30 to +100	Steel	40
		NBR 70 Low temp.	T	-45 to +80	Steel hardened	
		FKM 70	V	-10 to +200	Stainless steel	
		EPDM 70	E**	-45 to +145		
Turcon® T29 For lubricating and non-lubricating fluids Good extrusion resistance Surface texture is not suitable for gas sealing Not for electrically conducting fluids Carbon fiber filled Color: Gray	T29	NBR 70	N	-30 to +100	Steel	30
		NBR 70 Low temp.	T	-45 to +80	Steel hardened	
		FKM 70	V	-10 to +200	Cast iron	
		EPDM 70	E**	-45 to +145	Stainless steel	

Table continues on next page



Material, Applications, Properties	Code	O-Ring Material Shore A	Code	O-Ring Operating Temp.* °C	Mating Surface Material	MPa max. Dynamic
Turcon® T40 For lubricating and non-lubricating fluids High frequency and short strokes Water hydraulics Surface texture is not suitable for gas sealing Carbon fiber filled Color: Gray	T40	NBR 70	N	-30 to +100	Steel	25
		NBR 70 Low temp.	T	-45 to +80	Steel hardened Cast iron Stainless steel Aluminum	
		FKM 70	V	-10 to +200		
		EPDM 70	E**	-45 to +145		
Turcon® T46 For lubricated hydraulics in linear motion High compressive strength High extrusion resistance Very good sliding and wear properties BAM tested Bronze filled Color: Light to dark brown, which may have variations in shading	T46	NBR 70	N	-30 to +100	Steel hardened Cast iron	50
		NBR 70 Low temp.	T	-45 to +80		
		FKM 70	V	-10 to +200		
Zurcon® Z53*** For mineral oil based fluids Very high abrasion and extrusion resistance For counter surface with rougher surface finish Limited chemical resistance Max. working temperature 110 °C Cast polyurethane Color: Yellow to light-brown	Z53	NBR 70	N	-30 to +100	Steel	60
		NBR 70 Low temp.	T	-45 to +80	Steel hardened Steel chrome plated (rod) Cast iron Stainless steel Ceramic coating	
Zurcon® Z80 For lubricating and non-lubricating fluids Water based fluids, air and gases Dry air pneumatics High abrasion and extrusion resistance For service in abrasive conditions and medium with particles Good chemical resistance Limited temperature capability (-60 to +80 °C) UHMWPE (Ultra High Molecular Weight Polyethylene) Color: White to off-white	Z80	NBR 70	N	-30 to +100	Steel	35
		NBR 70 Low temp.	T	-45 to +80	Steel hardened Stainless steel Aluminum Ceramic coating	
		EPDM 70	E**	-45 to +145		

* The O-Ring Operation Temperature is only valid in mineral hydraulic oil (except EPDM).

** Material not suitable for mineral oils.

*** Max. diameter 2,300 mm.

BAM: Tested by "Bundesanstalt Materialprüfung, Germany".

Highlighted materials are recommended.



Installation Recommendation

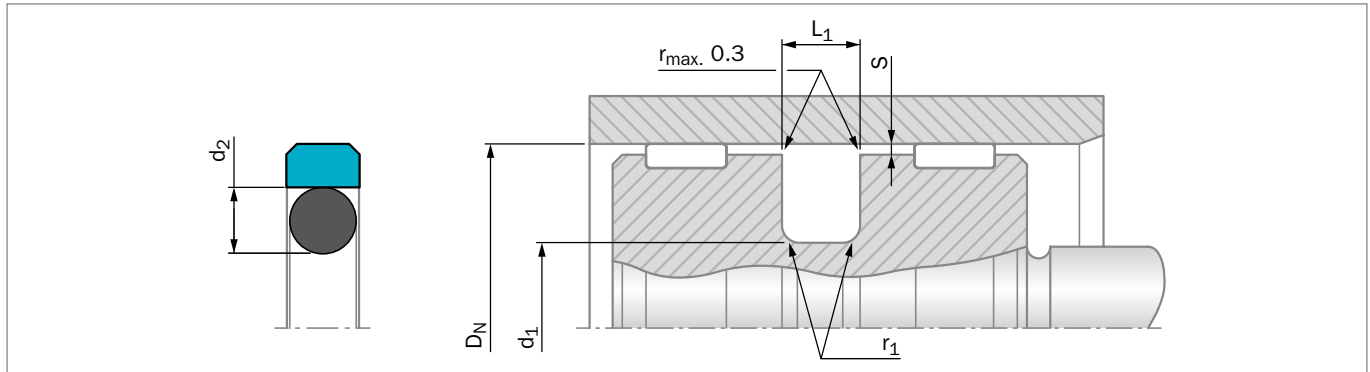

Figure 107: Installation Drawing

Table 85: Installation Dimensions – Standard Recommendations

Bore Diameter D_N H9			Groove Diameter	Groove Width	Radius	Radial Clearance S_{max}^*			O-Ring Cross Section
Series No. PG 44 Standard Application	Series No. PG 46 Light Application	Series No. PG 42 Heavy Duty Application	d_1 h9	L_1 +0.2	r_1 max	10 MPa	20 MPa	40 MPa	d_2
8 - 14.9	15 - 39.9	-	$D_N - 4.9$	2.2	0.4	0.30	0.20	0.15	1.78
15 - 39.9	40 - 79.9	8 - 14.9	$D_N - 7.5$	3.2	0.6	0.40	0.25	0.15	2.62
40 - 79.9	80 - 132.9	15 - 39.9	$D_N - 11.0$	4.2	1.0	0.40	0.25	0.20	3.53
80 - 132.9	133 - 329.9	40 - 79.9	$D_N - 15.5$	6.3	1.3	0.50	0.30	0.20	5.33
133 - 329.9	330 - 669.9	80 - 132.9	$D_N - 21.0$	8.1	1.8	0.60	0.35	0.25	7.00
330 - 669.9	670 - 999.9	133 - 329.9	$D_N - 24.5$	8.1	1.8	0.60	0.35	0.25	7.00
670 - 999.9	1,000 - 1,200	330 - 669.9	$D_N - 28.0$	9.5	2.5	0.70	0.50	0.30	8.40
1,000 - 2,700**	-	670 - 999.9	$D_N - 38.0$	13.8	3.0	1.00	0.70	0.60	12.00

* At pressures > 40 MPa use diameter tolerance H8/f8 (bore/piston) in the area of the seal or consult your local Customer Solution Center for alternative material or profiles.

Slydring® / Wear Rings are not applicable at very small radial clearances please consult the Slydring® section in this catalog.

** O-Rings with 12 mm cross section are delivered as special profile ring.

ORDERING EXAMPLE

Turcon® Glyd Ring® complete with O-Ring, standard application:

Series:	PG44 from Table 85
Bore Diameter:	$D_N = 80.0$ mm
TSS Part No.:	PG4400800 from Table 86

Select the material from Table 84. The corresponding code numbers are appended to the TSS Part No. Together these form the TSS Article Number. The TSS Article Number for all intermediate sizes can be determined by following the example:

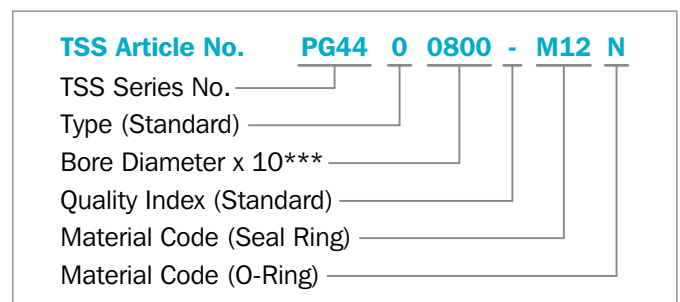

*** For diameters $D_N \geq 1,000.0$ mm multiply only by factor 1.
 Example: PG44 for diameter $D_N = 1,200.0$ mm
 TSS Article No.: PG44**X1200** - M12N



Table 86: Installation Dimensions / TSS Part No.

Bore Dia.	Groove Dia.	Groove Width	TSS Part No.	O-Ring Size	Bore Dia.	Groove Dia.	Groove Width	TSS Part No.	O-Ring Size
D _N H9	d ₁ h9	L ₁ +0.2			D _N H9	d ₁ h9	L ₁ +0.2		
8.0	3.1	2.2	PG4400080	2.57 x 1.78	50.0	34.5	6.3	PG4200500	32.69 x 5.33
10.0	5.1	2.2	PG4400100	4.80 x 1.80	50.8	43.3	3.2	PG4600508	42.52 x 2.62
12.0	7.1	2.2	PG4400120	6.70 x 1.80	50.8	39.8	4.2	PG4400508	37.69 x 3.53
14.0	9.1	2.2	PG4400140	8.75 x 1.80	52.0	41.0	4.2	PG4400520	40.87 x 3.53
15.0	7.5	3.2	PG4400150	7.00 x 2.62	53.0	42.0	4.2	PG4400530	40.87 x 3.53
16.0	11.1	2.2	PG4600160	10.60 x 1.80	55.0	44.0	4.2	PG4400550	44.04 x 3.53
16.0	8.5	3.2	PG4400160	7.59 x 2.62	57.0	46.0	4.2	PG4400570	44.04 x 3.53
18.0	13.1	2.2	PG4600180	12.42 x 1.78	58.0	47.0	4.2	PG4400580	47.22 x 3.53
18.0	10.5	3.2	PG4400180	9.19 x 2.62	60.0	49.0	4.2	PG4400600	47.22 x 3.53
19.05	11.5	3.2	PG4400190	10.77 x 2.62	62.0	51.0	4.2	PG4400620	50.39 x 3.53
20.0	15.1	2.2	PG4600200	14.00 x 1.78	63.0	52.0	4.2	PG4400630	50.39 x 3.53
20.0	12.5	3.2	PG4400200	12.37 x 2.62	63.0	47.5	6.3	PG4200630	46.99 x 5.33
21.0	13.5	3.2	PG4400210	12.37 x 2.62	65.0	54.0	4.2	PG4400650	53.57 x 3.53
22.0	17.1	2.2	PG4600220	17.17 x 1.78	68.0	57.0	4.2	PG4400680	56.74 x 3.53
22.0	14.5	3.2	PG4400220	13.94 x 2.62	70.0	62.5	3.2	PG4600700	61.60 x 2.62
24.0	16.5	3.2	PG4400240	15.54 x 2.62	70.0	59.0	4.2	PG4400700	56.74 x 3.53
25.0	20.1	2.2	PG4600250	19.00 x 1.80	70.0	54.5	6.3	PG4200700	53.34 x 5.33
25.0	17.5	3.2	PG4400250	17.12 x 2.62	75.0	64.0	4.2	PG4400750	63.09 x 3.53
25.0	14.0	4.2	PG4200250	13.87 x 3.53	75.0	59.5	6.3	PG4200750	56.52 x 5.33
25.4	20.5	2.2	PG4600254	20.35 x 1.78	80.0	69.0	4.2	PG4600800	66.27 x 3.53
28.0	20.5	3.2	PG4400280	20.29 x 2.62	80.0	64.5	6.3	PG4400800	62.87 x 5.33
30.0	25.1	2.2	PG4600300	25.12 x 1.78	80.0	59.0	8.1	PG4200800	58.00 x 7.00
30.0	22.5	3.2	PG4400300	21.89 x 2.62	82.5	67.0	6.3	PG4400825	66.04 x 5.33
32.0	27.1	2.2	PG4600320	26.70 x 1.78	85.0	69.5	6.3	PG4400850	69.22 x 5.33
32.0	24.5	3.2	PG4400320	23.47 x 2.62	85.0	64.0	8.1	PG4200850	63.00 x 7.00
32.0	21.0	4.2	PG4200320	20.22 x 3.53	90.0	79.0	4.2	PG4600900	78.97 x 3.53
34.0	29.1	2.2	PG4600340	28.30 x 1.78	90.0	74.5	6.3	PG4400900	72.39 x 5.33
35.0	27.5	3.2	PG4400350	26.64 x 2.62	90.0	69.0	8.1	PG4200900	68.00 x 7.00
35.0	24.0	4.2	PG4200350	23.40 x 3.53	95.0	84.0	4.2	PG4600950	82.14 x 3.53
36.0	28.5	3.2	PG4400360	28.24 x 2.62	95.0	79.5	6.3	PG4400950	78.74 x 5.33
38.0	33.1	2.2	PG4600380	33.05 x 1.78	95.0	74.0	8.1	PG4200950	73.00 x 7.00
38.0	30.5	3.2	PG4400380	29.82 x 2.62	100.0	89.0	4.2	PG4601000	88.49 x 3.53
40.0	32.5	3.2	PG4600400	31.42 x 2.62	100.0	84.5	6.3	PG4401000	81.92 x 5.33
40.0	29.0	4.2	PG4400400	28.17 x 3.53	100.0	79.0	8.1	PG4201000	78.00 x 7.00
42.0	31.0	4.2	PG4400420	29.75 x 3.53	101.6	86.1	6.3	PG4401016	85.09 x 5.33
44.45	36.9	3.2	PG4600444	36.17 x 2.62	105.0	94.0	4.2	PG4601050	91.67 x 3.53
45.0	34.0	4.2	PG4400450	32.92 x 3.53	105.0	89.5	6.3	PG4401050	88.27 x 5.33
48.0	37.0	4.2	PG4400480	36.09 x 3.53	108.0	92.5	6.3	PG4401080	91.44 x 5.33
50.0	42.5	3.2	PG4600500	40.94 x 2.62	110.0	99.0	4.2	PG4601100	98.02 x 3.53
50.0	39.0	4.2	PG4400500	37.69 x 3.53	110.0	94.5	6.3	PG4401100	91.44 x 5.33



Bore Dia.	Groove Dia.	Groove Width	TSS Part No.	O-Ring Size	Bore Dia.	Groove Dia.	Groove Width	TSS Part No.	O-Ring Size
D _N H9	d ₁ h9	L ₁ +0.2			D _N H9	d ₁ h9	L ₁ +0.2		
110.0	89.0	8.1	PG4201100	88.00 x 7.00	250.0	225.5	8.1	PG4202500	227.97 x 7.00
115.0	99.5	6.3	PG4401150	97.79 x 5.33	254.0	233.0	8.1	PG4402540	227.97 x 7.00
120.0	109.0	4.2	PG4601200	107.54 x 3.53	260.0	239.0	8.1	PG4402600	240.67 x 7.00
120.0	104.5	6.3	PG4401200	100.97 x 5.33	265.0	244.0	8.1	PG4402650	240.67 x 7.00
120.0	99.0	8.1	PG4201200	98.00 x 7.00	268.0	247.0	8.1	PG4402680	240.67 x 7.00
125.0	114.0	4.2	PG4601250	113.89 x 3.53	270.0	249.0	8.1	PG4402700	240.67 x 7.00
125.0	109.5	6.3	PG4401250	107.32 x 5.33	280.0	259.0	8.1	PG4402800	253.37 x 7.00
125.0	104.0	8.1	PG4201250	103.00 x 7.00	290.0	269.0	8.1	PG4402900	266.07 x 7.00
127.0	111.5	6.3	PG4401270	110.49 x 5.33	300.0	279.0	8.1	PG4403000	278.77 x 7.00
130.0	114.5	6.3	PG4401300	113.67 x 5.33	300.0	275.5	8.1	PG4203000	266.07 x 7.00
130.0	105.5	8.1	PG4201300	104.00 x 7.00	304.8	283.8	8.1	PG4403048	278.77 x 7.00
132.0	121.0	4.2	PG4601320	120.24 x 3.53	310.0	289.0	8.1	PG4403100	278.77 x 7.00
135.0	114.0	8.1	PG4401350	113.67 x 7.00	320.0	299.0	8.1	PG4403200	291.47 x 7.00
140.0	124.5	6.3	PG4601400	123.19 x 5.33	320.0	295.5	8.1	PG4203200	291.47 x 7.00
140.0	119.0	8.1	PG4401400	116.84 x 7.00	330.0	305.5	8.1	PG4403300	304.17 x 7.00
145.0	129.5	6.3	PG4601450	126.37 x 5.33	340.0	315.5	8.1	PG4403400	316.87 x 7.00
145.0	124.0	8.1	PG4401450	123.19 x 7.00	350.0	325.5	8.1	PG4403500	316.87 x 7.00
150.0	134.5	6.3	PG4601500	132.72 x 5.33	360.0	335.5	8.1	PG4403600	329.57 x 7.00
150.0	129.0	8.1	PG4401500	126.37 x 7.00	370.0	345.5	8.1	PG4403700	342.27 x 7.00
155.0	134.0	8.1	PG4401550	132.72 x 7.00	380.0	355.5	8.1	PG4403800	354.97 x 7.00
160.0	144.5	6.3	PG4601600	142.24 x 5.33	400.0	375.5	8.1	PG4404000	367.67 x 7.00
160.0	139.0	8.1	PG4401600	135.89 x 7.00	420.0	395.5	8.1	PG4404200	393.07 x 7.00
165.0	144.0	8.1	PG4401650	142.24 x 7.00	430.0	405.5	8.1	PG4404300	405.26 x 7.00
170.0	149.0	8.1	PG4401700	145.42 x 7.00	440.0	415.5	8.1	PG4404400	405.26 x 7.00
175.0	154.0	8.1	PG4401750	151.77 x 7.00	450.0	425.5	8.1	PG4404500	417.96 x 7.00
180.0	164.5	6.3	PG4601800	164.47 x 5.33	460.0	435.5	8.1	PG4404600	430.66 x 7.00
180.0	159.0	8.1	PG4401800	158.12 x 7.00	480.0	455.5	8.1	PG4404800	456.06 x 7.00
190.0	169.0	8.1	PG4401900	164.47 x 7.00	500.0	475.5	8.1	PG4405000	468.76 x 7.00
194.0	178.5	6.3	PG4601940	177.17 x 5.33	555.0	530.5	8.1	PG4405550	532.26 x 7.00
200.0	184.5	6.3	PG4602000	183.52 x 5.33	600.0	575.5	8.1	PG4406000	557.66 x 7.00
200.0	179.0	8.1	PG4402000	177.17 x 7.00	640.0	615.5	8.1	PG4406400	608.08 x 7.00
205.0	184.0	8.1	PG4402050	183.52 x 7.00	660.0	635.5	8.1	PG4406600	633.48 x 7.00
210.0	189.0	8.1	PG4402100	183.52 x 7.00	700.0	672.0	9.5	PG4407000	670.00 x 8.40
215.0	194.0	8.1	PG4402150	189.87 x 7.00	710.0	682.0	9.5	PG4407100	680.00 x 8.40
220.0	199.0	8.1	PG4402200	196.22 x 7.00	740.0	712.0	9.5	PG4407400	710.00 x 8.40
230.0	214.5	6.3	PG4602300	208.92 x 5.33	780.0	752.0	9.5	PG4407800	750.00 x 8.40
230.0	209.0	8.1	PG4402300	202.57 x 7.00	800.0	772.0	9.5	PG4408000	770.00 x 8.40
240.0	219.0	8.1	PG4402400	215.27 x 7.00	900.0	872.0	9.5	PG4409000	870.00 x 8.40
250.0	234.5	6.3	PG4602500	234.32 x 5.33	1,000.0	972.0	9.5	PG46X1000	970.00 x 8.40
250.0	229.0	8.1	PG4402500	227.97 x 7.00	1,000.0	962.0	13.8	PG44X1000	960.00 x 12.00



Bore Dia.	Groove Dia.	Groove Width	TSS Part No.	O-Ring Size
D_N H9	d₁ h9	L₁ +0.2		
1,050.0	1,022.0	9.5	PG46X1050	1,020.00 x 8.40
1,065.0	1,027.0	13.8	PG44X1065	1,025.00 x 12.00
1,070.0	1,032.0	13.8	PG44X1070	1,030.00 x 12.00
1,200.0	1,172.0	9.5	PG46X1200	1,170.00 x 8.40
1,200.0	1,162.0	13.8	PG44X1200	1,160.00 x 12.00
1,225.0	1,187.0	13.8	PG44X1225	1,185.00 x 12.00
1,500.0	1,462.0	13.8	PG44X1500	1,460.00 x 12.00
2,000.0	1,962.0	13.8	PG44X2000	1,960.00 x 12.00
2,700.0	2,662.0	13.8	PG44X2700	2,660.00 x 12.00

All dimensions in **bold** type are suitable for installation in grooves to ISO 7425-1, bore dia. in accordance with ISO 3320. Other dimensions and all intermediate sizes up to 2,700 mm dia. including inch sizes can be supplied.

All O-Rings with 12 mm cross section are delivered as special profile ring.

Turcon® Glyd Ring® T



Double-acting

Rubber-energized plastic-faced seal

Material:

Turcon®, Zurcon® and Elastomer



! This page is intentionally left blank.



Turcon® Glyd Ring® T*



Description

Turcon® Glyd Ring® T is a further technical development of Turcon® Glyd Ring®. It is fully interchangeable with earlier Glyd Ring® seals in all new applications.

The main benefits of the patented seal are provided by the innovative functional principle of the trapezoidal profile cross section. The sides of the seal profile tapers towards the seal surface. The profile can thus retain the robust and compact form typical of piston seals without losing any of the flexibility required to achieve a pressure-related maximum compression see Figure 108.

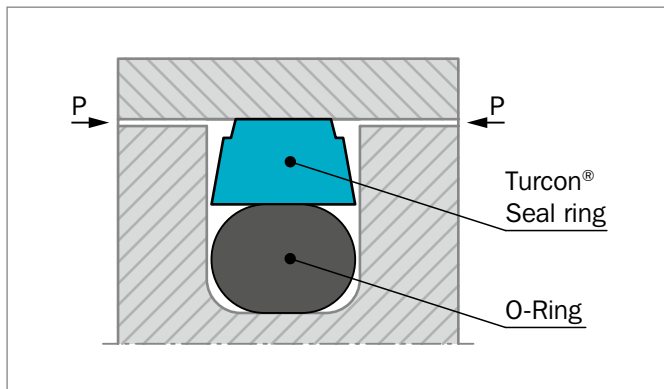

Figure 108: Turcon® Glyd Ring® T

The edge angle of Glyd Ring® T permits an additional degree of freedom and enables a slight tilting movement of the seal. The maximum compression is thus always shifted towards the area of the seal edge directly exposed to the pressure.

On the low-pressure edge of the seal Glyd Ring® T exhibits only zones with neutral strains without compressive or shearing loads, thus effectively reducing the danger of gap extrusion. The resulting benefits are as follows:

ADVANTAGES

- Very good static sealing performance
- Increased clearance possible (approximately +50%), depending on the operating conditions
- Due to the larger extrusion gap, safe use even with soiled media
- Low friction, no stick-slip effect
- Simple groove design, one-piece pistons possible
- Installation grooves to ISO 7425-1 as well as Stepseal® standard groove dimensions

- Adaptable to the operating conditions due to a wide range of materials (Turcon®, Zurcon®)
- Suitable for environmentally friendly hydraulic fluids
- Available for all cylinder diameters up to 2,700 mm.

APPLICATION EXAMPLES

Turcon® Glyd Ring® T is the recommended sealing element for double acting pistons of hydraulic components such as:

- Injection molding machines
- Machine tools
- Presses
- Excavators
- Forklifts & handling machinery
- Agriculture
- Valves for hydraulic & pneumatic circuits.
- Servo equipment
- Pressure intensifiers
- Jacks

It is particularly recommended for heavy duty and large diameter applications.

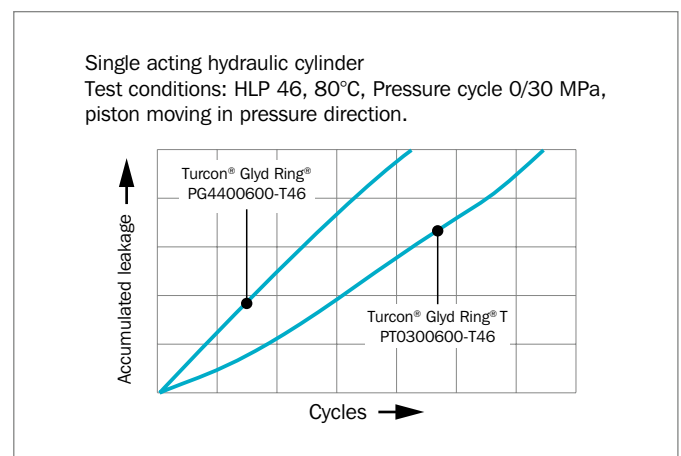

Figure 109: Dynamic leakage Turcon® Glyd Ring® T / Turcon® Glyd Ring® as single-acting piston seal

* Patent application: WO 92/19893 A1



OPERATING CONDITIONS

Pressure:	Up to 60 MPa
Speed:	Up to 15 m/s
Temperature:	-45 °C to +200 °C * depending on O-Ring material
Media:	Mineral oil-based hydraulic fluids, flame retardant hydraulic fluids, environmentally friendly hydraulic fluids (bio-oils), phosphate ester, water, air and others, depending on the seal and O-Ring material compatibility see Table 88.
Clearance:	The maximum permissible radial clearance S_{max} is shown in Table 89, as a function of the operating pressure and functional diameter.

IMPORTANT NOTE

The above data are maximum values and cannot be used at the same time, e.g. the maximum operating speed depends on material type, pressure, temperature and gap value. Temperature range also depends on media.

* In the case of unpressurized applications in temperatures below 0 °C please contact your local Customer Solution Center for more information!

SERIES

Different cross section sizes are recommended as a function of the seal diameters.

Table 89, shows the relationship between the series number according to the seal diameter range and the different application class sizes:

Standard application:	General applications without exceptional operating conditions.
Light application:	Applications with demands for reduced friction or for smaller grooves.
Heavy-duty application:	For exceptional operating loads such as high pressures, pressure peaks, etc.

Table 87: Available Range

Series No.	Piston Diameter D _N H9
PT00	8.0 - 140.0
PT01	8.0 - 200.0
PT02	16.0 - 380.0
PT03	40.0 - 480.0
PT04	80.0 - 700.0
PT08	133.0 - 999.9
PT05	310.0 - 999.9
PT05X	1,000.0 - 1,200.0
PT06	670.0 - 999.9
PT06X	1,000.0 - 2,700.0

For the recommended Standard Application range see Table 89.

INSTALLATION INSTRUCTIONS

Glyd Ring® T is installed according to information on page 247 to 249

Closed groove installation applies same dimensions as for Turcon® Glyd Ring® in Table 80 page 249.

RECOMMENDED MATERIALS

The following material combinations have proven effective for hydraulic applications:

Turcon® Glyd Ring® T in Turcon® M12

All round material for light to heavy hydraulic applications with linear or helical movements in mineral oils, flame retardant hydraulic fluids HFC, phosphate ester, bio-oils or fluids having low lubricating properties.

O-Ring:	NBR 70 Shore A	N
	FKM 70 Shore A	V

Set code: M12N or M12V

Turcon® Glyd Ring® T in Turcon® T46

For medium to heavy applications with linear movements in mineral oils and other media with good lubrication:

O-Ring:	NBR 70 Shore A	N
	FKM 70 Shore A	V

Set code: T46N or T46V

For specific applications, all Turcon® materials are available. Other material combinations are listed in Table 88.

**Table 88: Turcon® and Zurcon® Materials for Glyd Ring® T**

Material, Applications, Properties	Code	O-Ring Material Shore A	Code	O-Ring Operating Temp.* °C	Mating Surface Material	MPa max. Dynamic
Turcon® M12 First material choice for seals in linear motion Overall improved properties For new constructions and updating For all commonly applied hydraulic fluids including fluids with low lubrication performance Lowest friction and best sliding properties Lowest wear on seals Improved absorption of abrasive contaminants Low wear or abrasion of counter surface BAM tested Mineral fiber and Additives filled Color: Dark gray	M12	NBR 70	N	-30 to +100	Steel	40
		NBR 70 Low temp.	T	-45 to +80	Steel hardened Cast iron	
		FKM 70	V	-10 to +200	Stainless steel Titanium	
Turcon® T40 For lubricating and non-lubricating fluids Water hydraulics Surface texture is not suitable for gas sealing Carbon fiber filled Color: Gray	T40	NBR 70	N	-30 to +100	Steel	25
		NBR 70 Low temp.	T	-45 to +80	Steel hardened Cast iron	
		FKM 70	V	-10 to +200	Stainless steel Aluminum	
		EPDM 70	E**	-45 to +145		
Turcon® T46 For lubricated hydraulics in linear motion High compressive strength High extrusion resistance Very good sliding and wear properties BAM tested Bronze filled Color: Light to dark brown, which may have variations in shading	T46	NBR 70	N	-30 to +100	Steel hardened	50
		NBR 70 Low temp.	T	-45 to +80	Cast iron	
		FKM 70	V	-10 to +200		

Table continues on next page



Material, Applications, Properties	Code	O-Ring Material Shore A	Code	O-Ring Operating Temp.* °C	Mating Surface Material	MPa max. Dynamic
Zurcon® Z53*** For mineral oil based fluids Very high abrasion and extrusion resistance For counter surface with rougher surface finish Limited chemical resistance Max. working temperature 110 °C Cast polyurethane Color: Yellow to light-brown	Z53	NBR 70	N	-30 to +100	Steel	60
		NBR 70 Low temp.	T	-45 to +80	Steel hardened Steel chrome plated (rod) Cast iron Stainless steel Ceramic coating	
Zurcon® Z80 For lubricating and non-lubricating fluids Water based fluids, air and gases Dry air pneumatics High abrasion and extrusion resistance For service in abrasive conditions and media with particles Good chemical resistance Limited temperature capability (-60 to +80 °C) UHMWPE (Ultra High Molecular Weight Polyethylene) Color: White to off-white	Z80	NBR 70	N	-30 to +100	Steel	35
		NBR 70 Low temp.	T	-45 to +80	Steel hardened Stainless steel Aluminum	
		EPDM 70	E**	-45 to +145	Ceramic coating	

* The O-Ring Operation Temperature is only valid in mineral hydraulic oil (except EPDM).

** Material not suitable for mineral oils.

*** Max. diameter 2,300 mm.

BAM: Tested by "Bundesanstalt Materialprüfung, Germany".

 Highlighted materials are recommended.



Installation Recommendation

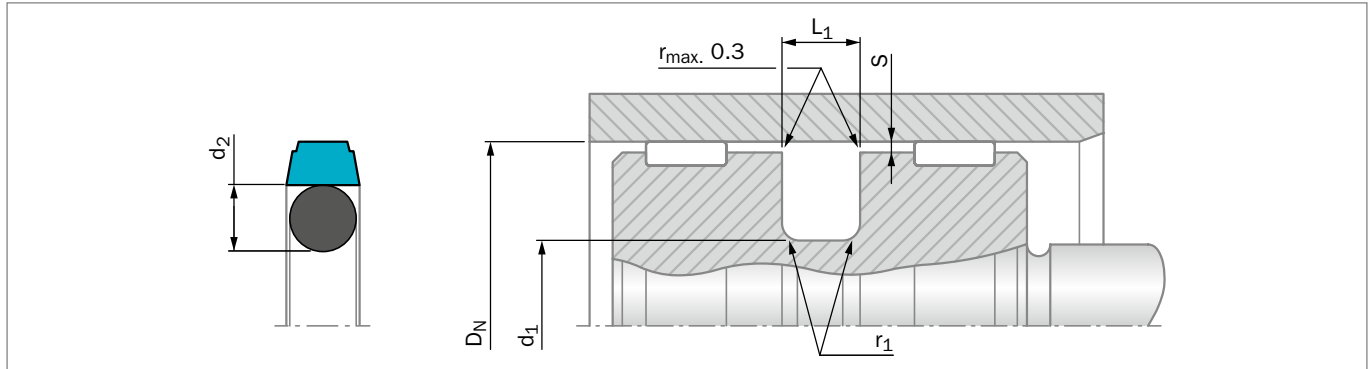

Figure 110: Installation Drawing

Table 89: Installation Dimensions – Standard Recommendations

Series No.	Bore Diameter D_N H9			Groove Diameter d_1 h9	Groove Width $L_1 + 0.2$	Radius r_1 max	Radial Clearance S_{max}^*			O-Ring Cross Section d_2
	Standard Application	Light Application	Heavy Duty Application				10 MPa	20 MPa	40 MPa	
PT00	8 - 15.9	16 - 39.9	–	$D_N - 4.9$	2.2	0.4	0.40	0.30	0.20	1.78
PT01	16 - 39.9	40 - 79.9	–	$D_N - 7.5$	3.2	0.6	0.60	0.50	0.30	2.62
PT02	40 - 79.9	80 - 132.9	16 - 39.9	$D_N - 11.0$	4.2	1.0	0.70	0.50	0.30	3.53
PT03	80 - 132.9	133 - 329.9	40 - 79.9	$D_N - 15.5$	6.3	1.3	0.80	0.60	0.40	5.33
PT04	133 - 329.9	330 - 669.9	80 - 132.9	$D_N - 21.0$	8.1	1.8	0.80	0.60	0.40	7.00
PT08	330 - 669.9	670 - 999.9	133 - 329.9	$D_N - 24.5$	8.1	1.8	0.90	0.70	0.50	7.00
PT05	670 - 999.9	–	310 - 669.9	$D_N - 28.0$	9.5	2.5	1.00	0.80	0.60	8.40
PT05X	–	1,000 - 1,200	–	$D_N - 28.0$	9.5	2.5	1.00	0.80	0.60	8.40
PT06**	–	–	670 - 999.9	$D_N - 38.0$	13.8	3.0	1.20	0.90	0.70	12.00
PT06X**	1,000 - 2,700	–	–	$D_N - 38.0$	13.8	3.0	1.20	0.90	0.70	12.00

* At pressures > 40 MPa use diameter tolerance H8/f8 (bore/piston) in the area of the seal or consult your local Customer Solution Center for alternative material or profiles.

Slydring® / Wear Rings are not applicable at very small radial clearances please consult the Slydring® section in this catalog.

** O-Rings with 12 mm cross section are delivered as special profile ring.

ORDERING EXAMPLE

Turcon® Glyd Ring® T complete with O-Ring, standard application:

Series: PT03 from Table 89

Bore diameter: $D_N = 80.0$ mm

TSS Part No.: PT0300800 from Table 90

Select the material from Table 88. The corresponding code numbers are appended to the TSS Part No. Together these form the TSS Article Number. The TSS Article Number for all intermediate sizes can be determined by following the example:

TSS Article No.	PT03	0	0800	-	M12	N
TSS Series No.	PT03	0	0800	-	M12	N
Type (Standard)						
Bore Diameter x 10***						
Quality Index (Standard)						
Material Code (Seal Ring)						
Material Code (O-Ring)						

*** For diameters $D_N \geq 1,000.0$ mm multiply only by factor 1.
 Example: PT06 for diameter $D_N = 1,200.0$ mm
 TSS Article No.: PT06X1200 - M12N



Table 90: Installation Dimensions / TSS Part No.

Bore Dia.	Groove Dia.	Groove Width	TSS Part No.	O-Ring Dimensions	Bore Dia.	Groove Dia.	Groove Width	TSS Part No.	O-Ring Dimensions
D_N H9	d_1 h9	L_1 +0.2			D_N H9	d_1 h9	L_1 +0.2		
8.0	3.1	2.2	PT0000080	2.57 x 1.78	50.8	39.8	4.2	PT0200508	37.69 x 3.53
10.0	5.1	2.2	PT0000100	4.47 x 1.78	52.0	41.0	4.2	PT0200520	40.87 x 3.53
12.0	7.1	2.2	PT0000120	6.70 x 1.80	53.0	42.0	4.2	PT0200530	40.87 x 3.53
14.0	9.1	2.2	PT0000140	8.75 x 1.80	55.0	44.0	4.2	PT0200550	44.04 x 3.53
15.0	7.5	3.2	PT0100150	6.98 x 2.62	57.0	46.0	4.2	PT0200570	44.04 x 3.53
15.8	10.9	2.2	PT0000158	10.60 x 1.80	58.0	47.0	4.2	PT0200580	47.22 x 3.53
16.0	11.1	2.2	PT0000160	10.60 x 1.80	60.0	49.0	4.2	PT0200600	47.22 x 3.53
16.0	8.5	3.2	PT0100160	7.59 x 2.62	62.0	51.0	4.2	PT0200620	50.39 x 3.53
18.0	13.1	2.2	PT0000180	12.42 x 1.78	63.0	52.0	4.2	PT0200630	50.39 x 3.53
18.0	10.5	3.2	PT0100180	9.19 x 2.62	63.0	47.5	6.3	PT0300630	46.99 x 5.33
19.05	11.5	3.2	PT0100190	10.77 x 2.62	65.0	54.0	4.2	PT0200650	53.57 x 3.53
20.0	15.1	2.2	PT0000200	14.00 x 1.78	68.0	57.0	4.2	PT0200680	56.74 x 3.53
20.0	12.5	3.2	PT0100200	12.37 x 2.62	70.0	59.0	4.2	PT0200700	56.74 x 3.53
21.0	13.5	3.2	PT0100210	12.37 x 2.62	70.0	54.5	6.3	PT0300700	53.34 x 5.33
22.0	17.1	2.2	PT0000220	17.17 x 1.78	75.0	64.0	4.2	PT0200750	63.09 x 3.53
22.0	14.5	3.2	PT0100220	13.94 x 2.62	75.0	59.5	6.3	PT0300750	56.52 x 5.33
24.0	16.5	3.2	PT0100240	15.54 x 2.62	80.0	69.0	4.2	PT0200800	66.27 x 3.53
25.0	20.1	2.2	PT0000250	19.00 x 1.80	80.0	64.5	6.3	PT0300800	62.87 x 5.33
25.0	17.5	3.2	PT0100250	17.12 x 2.62	80.0	59.0	8.1	PT0400800	58.00 x 7.00
25.0	14.0	4.2	PT0200250	13.87 x 3.53	82.5	67.0	6.3	PT0300825	66.04 x 5.33
25.4	20.5	2.2	PT0000254	20.35 x 1.78	85.0	69.5	6.3	PT0300850	69.22 x 5.33
28.0	20.5	3.2	PT0100280	20.29 x 2.62	85.0	64.0	8.1	PT0400850	63.00 x 7.00
30.0	22.5	3.2	PT0100300	21.89 x 2.62	90.0	79.0	4.2	PT0200900	78.97 x 3.53
32.0	27.1	2.2	PT0000320	26.70 x 1.78	90.0	74.5	6.3	PT0300900	72.39 x 5.33
32.0	24.5	3.2	PT0100320	23.47 x 2.62	90.0	69.0	8.1	PT0400900	68.00 x 7.00
32.0	21.0	4.2	PT0200320	20.22 x 3.53	95.0	84.0	4.2	PT0200950	82.14 x 3.53
35.0	27.5	3.2	PT0100350	26.64 x 2.62	95.0	79.5	6.3	PT0300950	78.74 x 5.33
35.0	24.0	4.2	PT0200350	23.40 x 3.53	95.0	74.0	8.1	PT0400950	73.00 x 7.00
36.0	28.5	3.2	PT0100360	28.24 x 2.62	100.0	89.0	4.2	PT0201000	88.49 x 3.53
38.0	30.5	3.2	PT0100380	29.82 x 2.62	100.0	84.5	6.3	PT0301000	81.92 x 5.33
40.0	32.5	3.2	PT0100400	31.42 x 2.62	100.0	79.0	8.1	PT0401000	78.00 x 7.00
40.0	29.0	4.2	PT0200400	28.17 x 3.53	101.6	86.1	6.3	PT0301016	85.09 x 5.33
42.0	31.0	4.2	PT0200420	29.75 x 3.53	105.0	94.0	4.2	PT0201050	91.67 x 3.53
44.45	36.95	3.2	PT0100444	36.17 x 2.62	105.0	89.5	6.3	PT0301050	88.27 x 5.33
45.0	34.0	4.2	PT0200450	32.92 x 3.53	108.0	92.5	6.3	PT0301080	91.44 x 5.33
48.0	37.0	4.2	PT0200480	36.09 x 3.53	110.0	99.0	4.2	PT0201100	98.02 x 3.53
50.0	42.5	3.2	PT0100500	40.94 x 2.62	110.0	94.5	6.3	PT0301100	91.44 x 5.33
50.0	39.0	4.2	PT0200500	37.69 x 3.53	110.0	89.0	8.1	PT0401100	88.00 x 7.00
50.0	34.5	6.3	PT0300500	32.69 x 5.33	115.0	99.5	6.3	PT0301150	97.79 x 5.33
50.8	43.3	3.2	PT0100508	42.52 x 2.62	120.0	109.0	4.2	PT0201200	107.54 x 3.53



Bore Dia.	Groove Dia.	Groove Width	TSS Part No.	O-Ring Dimensions	Bore Dia.	Groove Dia.	Groove Width	TSS Part No.	O-Ring Dimensions
D_N H9	d_1 h9	L_1 +0.2			D_N H9	d_1 h9	L_1 +0.2		
120.0	104.5	6.3	PT0301200	100.97 x 5.33	265.0	244.0	8.1	PT0402650	240.67 x 7.00
120.0	99.0	8.1	PT0401200	98.00 x 7.00	268.0	247.0	8.1	PT0402680	240.67 x 7.00
125.0	114.0	4.2	PT0201250	113.89 x 3.53	270.0	249.0	8.1	PT0402700	240.67 x 7.00
125.0	109.5	6.3	PT0301250	107.32 x 5.33	280.0	259.0	8.1	PT0402800	253.37 x 7.00
125.0	104.0	8.1	PT0401250	103.00 x 7.00	290.0	269.0	8.1	PT0402900	266.07 x 7.00
127.0	111.5	6.3	PT0301270	110.49 x 5.33	300.0	279.0	8.1	PT0403000	278.77 x 7.00
130.0	114.5	6.3	PT0301300	113.67 x 5.33	300.0	275.5	8.1	PT0803000	266.07 x 7.00
130.0	109.0	8.1	PT0401300	108.00 x 7.00	304.8	283.8	8.1	PT0403048	278.77 x 7.00
132.0	121.0	4.2	PT0201320	120.24 x 3.53	310.0	289.0	8.1	PT0403100	278.77 x 7.00
135.0	114.0	8.1	PT0401350	113.67 x 7.00	320.0	299.0	8.1	PT0403200	291.47 x 7.00
140.0	124.5	6.3	PT0301400	123.19 x 5.33	320.0	295.5	8.1	PT0803200	291.47 x 7.00
140.0	119.0	8.1	PT0401400	116.84 x 7.00	330.0	305.5	8.1	PT0803300	304.17 x 7.00
145.0	129.5	6.3	PT0301450	126.37 x 5.33	340.0	315.5	8.1	PT0803400	316.87 x 7.00
145.0	124.0	8.1	PT0401450	123.19 x 7.00	350.0	325.5	8.1	PT0803500	316.87 x 7.00
150.0	134.5	6.3	PT0301500	132.72 x 5.33	360.0	335.5	8.1	PT0803600	329.57 x 7.00
150.0	129.0	8.1	PT0401500	126.37 x 7.00	370.0	345.5	8.1	PT0803700	342.27 x 7.00
155.0	134.0	8.1	PT0401550	132.72 x 7.00	380.0	355.5	8.1	PT0803800	354.97 x 7.00
160.0	144.5	6.3	PT0301600	142.24 x 5.33	400.0	375.5	8.1	PT0804000	367.67 x 7.00
160.0	139.0	8.1	PT0401600	135.89 x 7.00	420.0	395.5	8.1	PT0804200	393.07 x 7.00
165.0	144.0	8.1	PT0401650	142.24 x 7.00	430.0	405.5	8.1	PT0804300	405.26 x 7.00
170.0	149.0	8.1	PT0401700	145.42 x 7.00	440.0	415.5	8.1	PT0804400	405.26 x 7.00
175.0	154.0	8.1	PT0401750	151.77 x 7.00	450.0	425.5	8.1	PT0804500	417.96 x 7.00
180.0	164.5	6.3	PT0301800	164.47 x 5.33	460.0	435.5	8.1	PT0804600	430.66 x 7.00
180.0	159.0	8.1	PT0401800	158.12 x 7.00	480.0	455.5	8.1	PT0804800	456.06 x 7.00
190.0	169.0	8.1	PT0401900	164.47 x 7.00	500.0	475.5	8.1	PT0805000	468.76 x 7.00
194.0	178.5	6.3	PT0301940	177.17 x 5.33	555.0	530.5	8.1	PT0805550	532.26 x 7.00
200.0	184.5	6.3	PT0302000	183.52 x 5.33	600.0	575.5	8.1	PT0806000	557.66 x 7.00
200.0	179.0	8.1	PT0402000	177.17 x 7.00	640.0	615.5	8.1	PT0806400	608.08 x 7.00
205.0	184.0	8.1	PT0402050	183.52 x 7.00	660.0	635.5	8.1	PT0806600	633.48 x 7.00
210.0	189.0	8.1	PT0402100	183.52 x 7.00	700.0	672.0	9.5	PT0507000	670.00 x 8.40
215.0	194.0	8.1	PT0402150	189.87 x 7.00	710.0	682.0	9.5	PT0507100	680.00 x 8.40
220.0	199.0	8.1	PT0402200	196.22 x 7.00	740.0	712.0	9.5	PT0507400	710.00 x 8.40
230.0	214.5	6.3	PT0302300	208.92 x 5.33	780.0	752.0	9.5	PT0507800	750.00 x 8.40
230.0	209.0	8.1	PT0402300	202.57 x 7.00	800.0	772.0	9.5	PT0508000	770.00 x 8.40
240.0	219.0	8.1	PT0402400	215.27 x 7.00	900.0	872.0	9.5	PT0509000	870.00 x 8.40
250.0	234.5	6.3	PT0302500	234.32 x 5.33	1,000.0	972.0	9.5	PT05X1000	970.00 x 8.40
250.0	229.0	8.1	PT0402500	227.97 x 7.00	1,000.0	962.0	13.8	PT06X1000	960.00 x 12.00
250.0	225.5	8.1	PT0802500	215.27 x 7.00	1,050.0	1,022.0	9.5	PT05X1050	1,020.00 x 8.40
254.0	233.0	8.1	PT0402540	227.97 x 7.00	1,065.0	1,027.0	13.8	PT06X1065	1,025.00 x 12.00
260.0	239.0	8.1	PT0402600	240.67 x 7.00	1,070.0	1,032.0	13.8	PT06X1070	1,030.00 x 12.00



Bore Dia.	Groove Dia.	Groove Width	TSS Part No.	O-Ring Dimensions
D_N H9	d_1 h9	L_1 +0.2		
1,200.0	1,172.0	9.5	PT05X1200	1,170.00 x 8.40
1,200.0	1,162.0	13.8	PT06X1200	1,160.00 x 12.00
1,225.0	1,187.0	13.8	PT06X1225	1,185.00 x 12.00
1,500.0	1,462.0	13.8	PT06X1500	1,460.00 x 12.00
2,000.0	1,962.0	13.8	PT06X2000	1,960.00 x 12.00
2,700.0	2,662.0	13.8	PT06X2700	2,660.00 x 12.00

All dimensions in **bold** type are suitable for installation in grooves to ISO 7425-1, bore diameter in accordance with ISO 3320.

Other dimensions and all intermediate sizes up to 2,700 mm diameter including inch sizes can be supplied.

All O-Rings with 12 mm cross section are delivered as special profile ring.

Turcon® Glyd Ring® Hz



Double-acting

Rubber-energized plastic-faced seal

Material:

Turcon®, Zurcon® and Elastomer



! This page is intentionally left blank.



■ Turcon® Glyd Ring® Hz



■ Description

Glyd Ring® Hz is a symmetric single and double acting piston seal particular for applications with short-stroke high-frequency linear movements. It is designed to fit into ISO 7425-1 housing grooves.

Glyd Ring® Hz is wider than Turcon® Glyd Ring® giving a tighter fit in the housing groove and limiting its axial movement. It also prevents the seal from being damaged under short-stroke high-frequency movement. Furthermore it eliminates the risk of wear between O-Ring and seal.

Glyd Ring® Hz has notches on both sides to ensure system pressure instantly can activate the O-Ring under the seal despite the tighter fit and the fast alternation of pressure direction.

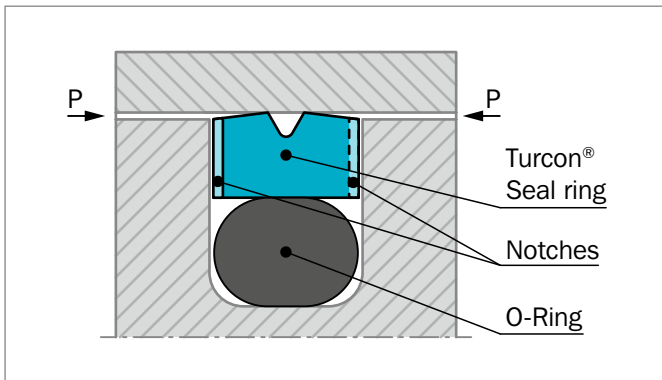

Figure 111: Turcon® Glyd Ring® Hz – short-stroke

The angled contact faces ensure that oil film is not scraped away from the surface but is transported into the groove in the middle of the contact area forming an oil reservoir for lubrication. Wear particles are also likely to be captured in this groove, thus preventing them from embedding in the surface where the highest contact force occurs.

DEFINITION

Short-stroke high-frequency movements are conditions, which in combination can cause problems, in hydraulic systems:

Short-Stroke: $\leq 3 \times G$ (Groove width)

Very short reciprocating movements can cause reduced service life due to insufficient lubrication film, giving an increasing temperature on a limited area. These factors increase wear on seal and hardware and wear particles will not be removed from the seal face.

High-Frequency: Reciprocating movement above 5 Hz.

With an increasing frequency the formation of lubrication under the contact face is reduced. High-frequency is most often occurring in connection with short-strokes. These two types of movements together accelerate the wear on hardware and seal.

ADVANTAGES

- Seal face gets lubricated in short-stroke high-frequency linear movements
- Low friction
- No stick-slip effect
- Single and double acting
- High wear resistance
- Installation grooves acc. to ISO 7425-1
- No adhesive effect to the mating surface during long period of inactivity or storage
- Available for all cylinder diameters up to 999.9 mm. (For diameter $\geq 1,000$ mm TSS special article number is required)

APPLICATION EXAMPLES

Glyd Ring® Hz has been successfully implemented in a large variety of applications as double acting piston seal for hydraulic components such as:

- Injection molding machines
- Machine tools
- Press brakes
- Handling machinery
- Servo equipment
- Pressure intensifiers
- Shock absorbers
- Wind power pitch cylinders



OPERATING CONDITIONS

Pressure:	Up to 30 MPa with mineral oil (depending on seal material)
Speed:	Up to 15 m/s with linear movements
Temperature:	-45 °C to +200 °C* depending on Seal and O-Ring material
Media:	Mineral oil and other fluids with very high lubricity depending on temperature, seal and O-Ring material compatibility
Clearance:	The maximum permissible radial clearance S_{max} is shown in Table 92 as a function of the operating pressure and functional diameter.

IMPORTANT NOTE

The above data are maximum values and cannot be used at the same time, e.g. the maximum operating speed depends on material type, pressure, temperature and gap value. Temperature range also depends on media

* In the case of unpressurized applications in temperatures below 0 °C please contact your local Customer Solution Center for more information!

HARDWARE

Short-stroke high-frequency can cause heavy wear on hardware due to poor lubrication under the seal and the fact that wear products cannot be removed from the contact area. The hardest possible hardware material should be recommended, especially when system pressure is above 10 MPa.

INSTALLATION INSTRUCTIONS

Glyd Ring® Hz is installed according to information on page 247 to 249.

Closed groove installation applies the same limits for cylinder diameter D_N as for Turcon® Glyd Ring® in Table 80 page 249.

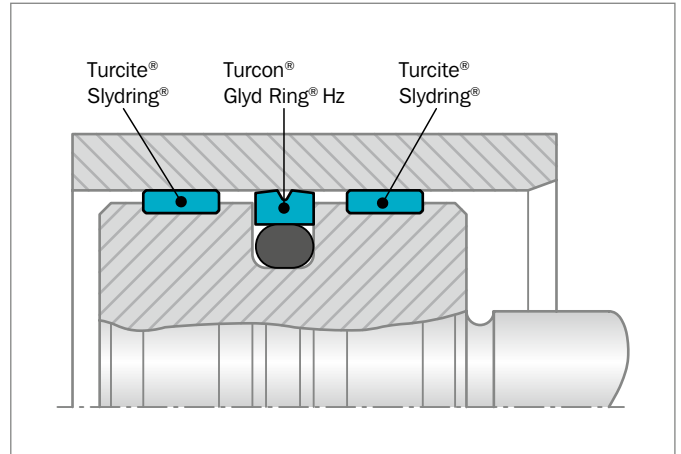

Figure 112: Turcon® Glyd Ring® Hz installed with Turcite® Slydring®

Tandem seal installation of Glyd Ring® Hz cannot be recommended as the short-strokes create a risk of pressure build-up between the seals.

RECOMMENDED MATERIALS

The following material combinations have proven effective for short-stroke and/or high-frequency applications:

Turcon® Glyd Ring® Hz in Turcon® M12

All round material for hydraulic applications with linear, short-stroke and/or high-frequency movements in mineral oils and fluids having high lubricating properties:

O-Ring: NBR 70 Shore A N
 FKM 70 Shore A V
 depending on medium and temperature

Set code: M12N or M12V

Turcon® Glyd Ring® Hz in Turcon® T49

For medium to heavy applications with linear, short-stroke and/or high-frequency movements in mineral oils:

O-Ring: NBR 70 Shore A N
 FKM 70 Shore A V
 depending on medium and temperature

Set code: T49N or T49V

**Turcon® Glyd Ring® Hz in Turcon® T40**

For light to medium applications with linear, short-stroke and/or high-frequency movements in fluids with lower lubricating properties:

O-Ring: NBR 70 Shore A N
 FKM 70 Shore A V
 EPDM, 70 Shore A E
 depending on medium and temperature

Set code: T40N, T40V or T40E

Zurcon® Glyd Ring® Hz in Zurcon® Z80

For light applications with linear, short-stroke and/or high-frequency movements in water based fluids, air and gases at reduced pressure and frequencies due to the temperature limitation of the material:

O-Ring: NBR 70 Shore A N
 EPDM, 70 Shore A E
 depending on medium and temperature

Set code: Z80N or Z80E



Table 91: Turcon® and Zurcon® Materials for Glyd Ring® Hz

Material, Applications, Properties	Code	O-Ring Material Shore A	Code	O-Ring Operating Temp.* °C	Mating Surface Material	MPa max. Dynamic
Turcon® M12 First material choice for seals in linear motion with high-frequency and short-strokes For new constructions and updating For commonly applied hydraulic fluids Lowest friction and best sliding properties Lowest wear on seals Improved absorption of abrasive contaminants Low wear or abrasion of counter surface BAM tested Mineral fiber and Additives filled Color: Dark gray	M12	NBR 70	N	-30 to +100	Steel (tubes)	30
		NBR 70 Low temp.	T	-45 to +80	Steel hardened Cast iron	
		FKM 70	V	-10 to +200	Stainless steel Titanium	
Turcon® T40 For lubricating fluids and fluids with lower lubrication performance Water hydraulics at reduced pressure and frequency Surface texture is only suitable for gas sealing when lubricated with fluid Carbon fiber filled Color: Gray	T40	NBR 70	N	-30 to +100	Steel	25
		NBR 70 Low temp.	T	-45 to +80	Steel hardened Cast iron	
		FKM 70	V	-10 to +200	Stainless steel Aluminum	
		EPDM 70	E**	-45 to +145		
Turcon® T49 For lubricated hydraulics in linear motion High compressive strength High extrusion resistance Very good sliding and wear properties Surface treated for very quick run-in BAM tested Bronze filled Color: Light to dark brown, which may have variations in shading	T49	NBR 70	N	-30 to +100	Steel (tubes)	30
		NBR 70 Low temp.	T	-45 to +80	Steel hardened Cast iron	
		FKM 70	V	-10 to +200		

Table continues on next page



Material, Applications, Properties	Code	O-Ring Material Shore A	Code	O-Ring Operating Temp.* °C	Mating Surface Material	MPa max. Dynamic
Zurcon® Z80 For low frequencies due to the temperature limitation of the material For lubricating fluids and fluids with lower lubrication performance Water based fluids, air and gases at reduced pressure Dry air pneumatics High abrasion and extrusion resistance For service in abrasive conditions and media with particles Good chemical resistance Limited temperature capability (-60 to +80 °C) UHMWPE (Ultra High Molecular Weight Polyethylene) Color: White to off-white	Z80	NBR 70	N	-30 to (+100)	Steel	25
		NBR 70 Low temp.	T	-45 to +80	Steel hardened Stainless steel Aluminum	
		EPDM 70	E**	-45 to (+145)	Ceramic coating	

* The O-Ring Operation Temperature is only valid in mineral hydraulic oil (except EPDM).

** Material not suitable for mineral oils.

BAM: Tested by "Bundesanstalt Materialprüfung, Germany".

Highlighted materials are recommended.



■ Installation Recommendation

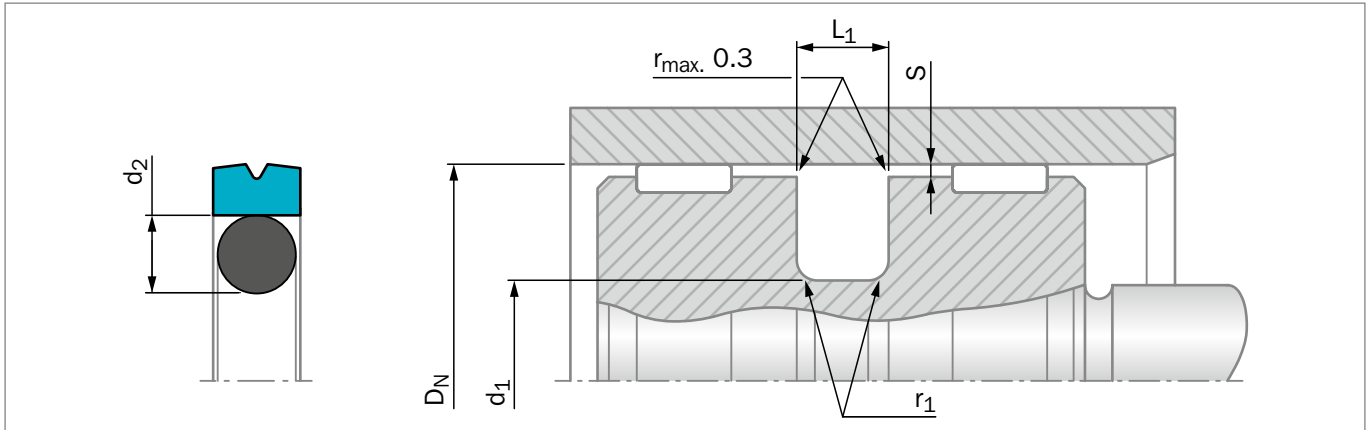

Figure 113: Installation Drawing

Table 92: Installation Dimensions – Standard Recommendations

Series No.	Bore Diameter D_N H9		Groove Diameter d_1 h9	Groove Width $L_1 + 0.2$	Radius r_1 max	Radial Clearance S_{max}^*			O-Ring Cross Section d_2
	Standard Application	Available Range				10 MPa	20 MPa	30 MPa	
PGS0	8 - 14.9	8 - 140.0	$D_N - 5.0^{**}$	2.2	0.4	0.25	0.20	0.15	1.78
PGS1	15 - 39.9	14 - 260.0	$D_N - 7.5$	3.2	0.6	0.40	0.35	0.20	2.62
PGS2	40 - 79.9	22 - 480.0	$D_N - 11.0$	4.2	1.0	0.45	0.40	0.20	3.53
PGS3	80 - 132.9	40 - 750.0	$D_N - 15.5$	6.3	1.3	0.55	0.45	0.25	5.33
PGS4	133 - 329.9	110 - 750.0	$D_N - 21.0$	8.1	1.8	0.60	0.50	0.30	7.00
PGS8***	330 - 669.9	133 - 999.9	$D_N - 24.5$	8.1	1.8	0.60	0.50	0.30	7.00
PGS5***	670 - 999.9	320 - 999.9	$D_N - 28.0$	9.5	2.5	0.65	0.55	0.35	8.40

* At pressures > 30 MPa use diameter tolerance H8/f8 (bore/piston) in the area of the seal or consult your local Customer Solution Center for alternative material or profiles.

Slydring® / Wear Rings are not applicable at very small radial clearances please consult the Slydring® section in this catalog.

** Can also be used in Turcon® Glyd Ring® T groove $D_N - 4.9$ mm.

*** Grooves are not according to ISO 7425-1

ORDERING EXAMPLE

Glyd Ring® Hz complete with O-Ring, standard application:

Series:	PGS30 from Table 92
Bore Diameter:	$D_N = 80.0$ mm
TSS Part No.:	PGS300800 from Table 93

Select the material from Table 91. The corresponding code numbers are appended to the TSS Part No. Together they form the TSS Article Number. The TSS Article No. for all intermediate sizes can be determined by following the example:

TSS Article No.	PGS3	0	0800	-	M12	N
Series No.	PGS3	0	0800	-	M12	N
Type (Standard)						
Bore Diameter x 10****						
Quality Index (Standard)						
Material Code (Seal Ring)						
Material Code (O-Ring)						

**** For diameters $D_N \geq 1,000$ mm only on TSS Special Article Number.

Note:
Installation Dimensions for piston sealing the groove dimensions are identical to Glyd Ring® T and Glyd Ring® PG44.



Table 93: Installation Dimensions / TSS Part No.

Bore	Groove Dia.	Groove Width	Part No.	O-Ring Sizes	Bore	Groove Dia.	Groove Width	Part No.	O-Ring Sizes
D _N H9	d ₁ h9	L ₁ +0.2			D _N H9	d ₁ h9	L ₁ +0.2		
8.0	3.0	2.2	PGS000080	2.57 x 1.78	53.0	42.0	4.2	PGS200530	40.87 x 3.53
10.0	5.0	2.2	PGS000100	4.47 x 1.78	55.0	44.0	4.2	PGS200550	44.04 x 3.53
12.0	7.0	2.2	PGS000120	6.70 x 1.80	57.0	46.0	4.2	PGS200570	44.04 x 3.53
14.0	9.0	2.2	PGS000140	8.75 x 1.80	58.0	47.0	4.2	PGS200580	47.22 x 3.53
15.0	7.5	3.2	PGS100150	6.93 x 2.62	60.0	49.0	4.2	PGS200600	47.22 x 3.53
16.0	11.0	2.2	PGS000160	10.60 x 1.80	62.0	51.0	4.2	PGS200620	50.39 x 3.53
18.0	13.0	2.2	PGS000180	12.42 x 1.78	63.0	52.0	4.2	PGS200630	50.39 x 3.53
18.0	10.5	3.2	PGS100180	9.19 x 2.62	63.0	47.5	6.3	PGS300630	46.99 x 5.33
19.0	11.5	3.2	PGS100190	10.77 x 2.62	65.0	54.0	4.2	PGS200650	53.57 x 3.53
20.0	15.0	2.2	PGS000200	14.00 x 1.78	68.0	57.0	4.2	PGS200680	56.74 x 3.53
20.0	12.5	3.2	PGS100200	12.37 x 2.62	70.0	59.0	4.2	PGS200700	56.74 x 3.53
21.0	13.5	3.2	PGS100210	12.37 x 2.62	70.0	54.5	6.3	PGS300700	53.34 x 5.33
22.0	17.0	2.2	PGS000220	15.60 x 1.78	75.0	64.0	4.2	PGS200750	63.09 x 3.53
22.0	14.5	3.2	PGS100220	13.94 x 2.62	75.0	59.5	6.3	PGS300750	56.52 x 5.33
24.0	16.5	3.2	PGS100240	15.54 x 2.62	80.0	69.0	4.2	PGS200800	66.27 x 3.53
25.0	20.0	2.2	PGS000250	19.00 x 1.80	80.0	64.5	6.3	PGS300800	62.87 x 5.33
25.0	17.5	3.2	PGS100250	17.12 x 2.62	82.5	67.0	6.3	PGS300825	66.04 x 5.33
25.0	14.0	4.2	PGS200250	12.29 x 3.53	85.0	69.5	6.3	PGS300850	66.04 x 5.33
25.4	20.4	2.2	PGS000254	20.35 x 1.78	90.0	79.0	4.2	PGS200900	78.97 x 3.53
28.0	20.5	3.2	PGS100280	20.29 x 2.62	90.0	74.5	6.3	PGS300900	72.39 x 5.33
30.0	22.5	3.2	PGS100300	21.89 x 2.62	95.0	84.0	4.2	PGS200950	82.14 x 3.53
32.0	27.0	2.2	PGS000320	26.70 x 1.78	95.0	79.5	6.3	PGS300950	78.74 x 5.33
32.0	24.5	3.2	PGS100320	23.47 x 2.62	100.0	89.0	4.2	PGS201000	88.49 x 3.53
32.0	21.0	4.2	PGS200320	20.22 x 3.53	100.0	84.5	6.3	PGS301000	81.92 x 5.33
35.0	27.5	3.2	PGS100350	26.64 x 2.62	101.6	86.1	6.3	PGS301016	85.09 x 5.33
35.0	24.0	4.2	PGS200350	23.40 x 3.53	105.0	94.0	4.2	PGS201050	91.67 x 3.53
36.0	28.5	3.2	PGS100360	28.24 x 2.62	105.0	89.5	6.3	PGS301050	88.27 x 5.33
38.0	30.5	3.2	PGS100380	29.82 x 2.62	108.0	92.5	6.3	PGS301080	91.44 x 5.33
40.0	32.5	3.2	PGS100400	31.42 x 2.62	110.0	99.0	4.2	PGS201100	98.02 x 3.53
40.0	29.0	4.2	PGS200400	28.17 x 3.53	110.0	94.5	6.3	PGS301100	91.44 x 5.33
42.0	31.0	4.2	PGS200420	29.75 x 3.53	110.0	89.0	8.1	PGS401100	87.60 x 7.00
44.4	36.9	3.2	PGS100444	36.17 x 2.62	115.0	99.5	6.3	PGS301150	97.79 x 5.33
45.0	34.0	4.2	PGS200450	32.92 x 3.53	120.0	109.0	4.2	PGS201200	107.54 x 3.53
48.0	37.0	4.2	PGS200480	36.09 x 3.53	120.0	104.5	6.3	PGS301200	100.97 x 5.33
50.0	42.5	3.2	PGS100500	40.94 x 2.62	120.0	99.0	8.1	PGS401200	97.60 x 7.00
50.0	39.0	4.2	PGS200500	37.69 x 3.53	125.0	114.0	4.2	PGS201250	110.72 x 3.53
50.0	34.5	6.3	PGS300500	32.69 x 5.33	125.0	109.5	6.3	PGS301250	107.32 x 5.33
50.8	43.3	3.2	PGS100508	42.52 x 2.62	125.0	104.0	8.1	PGS401250	102.60 x 7.00
50.8	39.8	4.2	PGS200508	37.69 x 3.53	127.0	111.5	6.3	PGS301270	110.49 x 5.33
52.0	41.0	4.2	PGS200520	40.87 x 3.53	130.0	114.5	6.3	PGS301300	113.67 x 5.33



Bore	Groove Dia.	Groove Width	Part No.	O-Ring Sizes
D _N H9	d ₁ h9	L ₁ +0.2		
130.0	109.0	8.1	PGS401300	107.60 x 7.00
132.0	121.0	4.2	PGS201320	120.24 x 3.53
135.0	114.0	8.1	PGS401350	113.67 x 7.00
140.0	124.5	6.3	PGS301400	123.19 x 5.33
140.0	119.0	8.1	PGS401400	116.84 x 7.00
145.0	129.5	6.3	PGS301450	126.37 x 5.33
145.0	124.0	8.1	PGS401450	123.19 x 7.00
150.0	134.5	6.3	PGS301500	132.72 x 5.33
150.0	129.0	8.1	PGS401500	126.37 x 7.00
155.0	134.0	8.1	PGS401550	132.72 x 7.00
160.0	144.5	6.3	PGS301600	142.24 x 5.33
160.0	139.0	8.1	PGS401600	135.89 x 7.00
165.0	144.0	8.1	PGS401650	142.24 x 7.00
170.0	149.0	8.1	PGS401700	145.42 x 7.00
175.0	154.0	8.1	PGS401750	151.77 x 7.00
180.0	164.5	6.3	PGS301800	164.47 x 5.33
180.0	159.0	8.1	PGS401800	158.12 x 7.00
190.0	169.0	8.1	PGS401900	164.47 x 7.00
194.0	178.5	6.3	PGS301940	177.17 x 5.33
200.0	184.5	6.3	PGS302000	183.52 x 5.33
200.0	179.0	8.1	PGS402000	177.17 x 7.00
205.0	184.0	8.1	PGS402050	183.52 x 7.00
210.0	189.0	8.1	PGS402100	183.52 x 7.00
215.0	194.0	8.1	PGS402150	189.87 x 7.00
220.0	199.0	8.1	PGS402200	196.22 x 7.00
230.0	214.5	6.3	PGS302300	208.92 x 5.33
230.0	209.0	8.1	PGS402300	202.57 x 7.00
240.0	219.0	8.1	PGS402400	215.27 x 7.00
250.0	234.5	6.3	PGS302500	234.32 x 5.33
250.0	229.0	8.1	PGS402500	227.97 x 7.00
250.0	225.5	8.1	PGS802500	215.27 x 7.00
254.0	233.0	8.1	PGS402540	227.97 x 7.00
260.0	239.0	8.1	PGS402600	240.67 x 7.00
265.0	244.0	8.1	PGS402650	240.67 x 7.00
268.0	247.0	8.1	PGS402680	240.67 x 7.00
270.0	249.0	8.1	PGS402700	240.67 x 7.00

Bore	Groove Dia.	Groove Width	Part No.	O-Ring Sizes
D _N H9	d ₁ h9	L ₁ +0.2		
280.0	259.0	8.1	PGS402800	253.37 x 7.00
290.0	269.0	8.1	PGS402900	266.07 x 7.00
300.0	279.0	8.1	PGS403000	278.77 x 7.00
300.0	275.5	8.1	PGS803000	266.07 x 7.00
304.8	283.8	8.1	PGS403048	278.77 x 7.00
310.0	289.0	8.1	PGS403100	278.77 x 7.00
320.0	299.0	8.1	PGS403200	291.47 x 7.00
320.0	295.5	8.1	PGS803200	291.47 x 7.00
330.0	305.5	8.1	PGS803300	304.17 x 7.00
340.0	315.5	8.1	PGS803400	316.87 x 7.00
350.0	325.5	8.1	PGS803500	316.87 x 7.00
360.0	335.5	8.1	PGS803600	329.57 x 7.00
370.0	345.5	8.1	PGS803700	342.27 x 7.00
380.0	355.5	8.1	PGS803800	354.97 x 7.00
400.0	375.5	8.1	PGS804000	367.67 x 7.00
420.0	395.5	8.1	PGS804200	393.07 x 7.00
430.0	405.5	8.1	PGS804300	405.26 x 7.00
440.0	415.5	8.1	PGS804400	405.26 x 7.00
450.0	425.5	8.1	PGS804500	417.96 x 7.00
460.0	435.5	8.1	PGS804600	430.66 x 7.00
480.0	455.5	8.1	PGS804800	456.06 x 7.00
500.0	475.5	8.1	PGS805000	468.76 x 7.00
555.0	530.5	8.1	PGS805550	532.26 x 7.00
600.0	575.5	8.1	PGS806000	557.66 x 7.00
640.0	615.5	8.1	PGS806400	608.08 x 7.00
660.0	635.5	8.1	PGS806600	633.48 x 7.00
700.0	672.0	9.5	PGS507000	670.30 x 8.40
710.0	682.0	9.5	PGS507100	680.30 x 8.40
740.0	712.0	9.5	PGS507400	710.30 x 8.40
780.0	752.0	9.5	PGS507800	750.30 x 8.40
800.0	772.0	9.5	PGS508000	770.30 x 8.40
900.0	872.0	9.5	PGS509000	870.30 x 8.40

The bore diameters in **bold** type comply with the recommendations of ISO 3320. Part No. for other dimensions and **all** intermediate dimensions up to 999.9 mm diameter including imperial (inch) dimensions can be supplied.

Larger dimensions up to 2,700 mm are available upon request.

Zurcon® Glyd Ring® D



Double-acting

Rubber-energized plastic-faced seal

High Extrusion Resistance

Material:

Zurcon® and Elastomer



! This page is intentionally left blank.



Zurcon Glyd Ring® D



Description

Glyd Ring® D is a double-acting seal consisting of a premium polyurethane Zurcon® Z13 seal ring and an O-Ring as energizing element (Figure 114).

The innovative D-shape design optimizes contact pressure and the two special grooves incorporated keep an oil reservoir for an adequate lubrication that minimizes heat generated by friction forces. The above features give the perfect combination of sealing performance and service life.

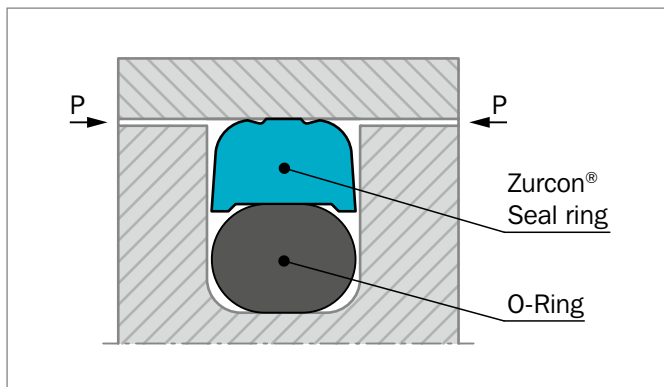

Figure 114: Zurcon® Glyd Ring® D

Zurcon® Z13 polyurethane material is the perfect partner for this innovative design. It is the latest advanced polyurethane development matching the requirements of modern hydraulic medias and cylinder bore surfaces.

Zurcon® Z13 is a 60 ShD polyurethane able to combine excellent mechanical and elastic material properties that makes it suitable to work in high pressure and temperature environment without losing performance.

It has been developed in order to have an excellent hydrolysis resistance making it compatible with a wide range of hydraulic fluids not only mineral base, but also the new environmentally friendly fluids (HEES, HEPG and HEPR) and also with fire resistant fluids both water based and water free (HFA, HFC and HFD) .

ADVANTAGES

- Extended service life in heavy duty applications
- High static and dynamic sealing effect
- Excellent abrasion and extrusion resistance
- Simple groove design, one piece piston possible, easy installation
- Grooves according to ISO 7425-1

APPLICATION EXAMPLES

Glyd Ring® D is the recommended element for double acting pistons of hydraulic components such as:

- Construction machinery
- Mobile hydraulic
- Truck cranes
- Fork lift
- Accumulators

It is particularly recommended for medium and heavy duty applications.

RECOMMENDED MATERIALS

Glyd Ring® D: Zurcon® Z13

O-Ring: NBR, 70 Shore A N
HNBR, 70 Shore A H

Set code: Z13N or Z13H

OPERATING CONDITIONS

Pressure:	Up to 40 MPa
Velocity:	Up to 0.5 m/s 0.8 m/s for limited time
Frequency:	Up to 5 Hz
Temperature:	-30° C to +110° C depending on O-Ring Material
Media:	Hydraulic fluids based on mineral oil, environmentally friendly and fire resistance fluids (always check O-Ring material compatibility)
Clearance:	The maximum permissible radial clearance S_{max} is shown in Table 94 as a function of the operating pressure and diameter

IMPORTANT NOTE

The above started limits for pressure and speed are maximum values individually. Friction heat generated by the combination of pressure and speed may cause local heat built-up. Care should be taken not to apply high values for pressure and speed at the same time.



■ Installation Recommendation

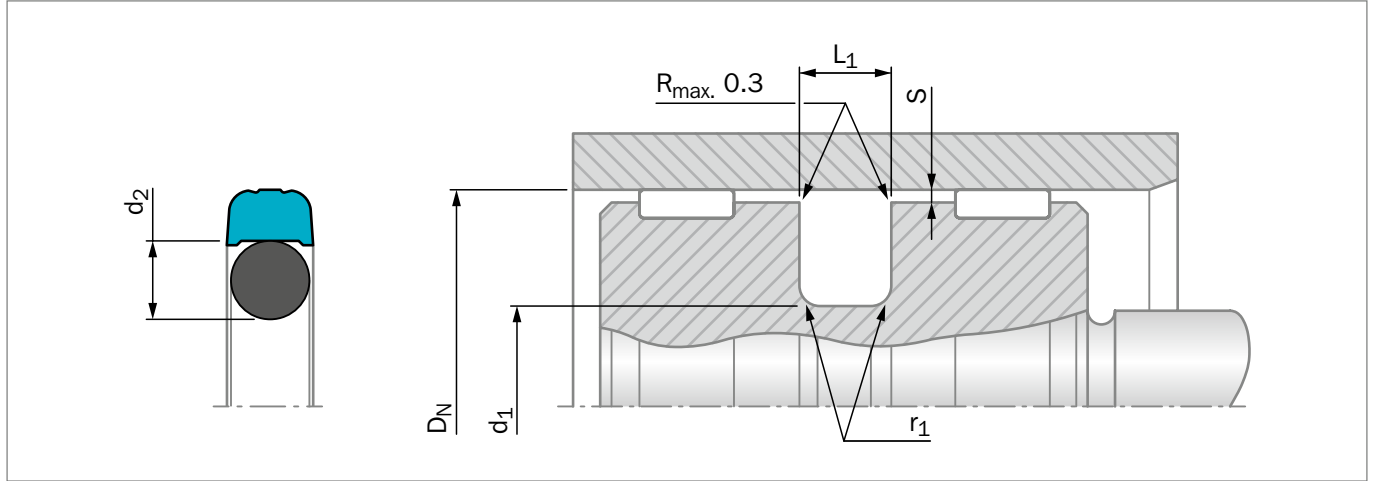

Figure 115: Installation Drawing

Table 94: Installation Dimensions – Standard Recommendations

Series No.	Diameter Range	Groove Diameter	Groove Width	Radius	Radial Clearance S_{max} @ 110°C				O-Ring Cross Section
	D_N H9	d_1 h9	L_1 +0.2	r_1	16 MPa	26 MPa	32 MPa	40 MPa	d_2
PH41	15 - 39.9	DN - 7.5	3.2	0.6	0.3	0.2	-	-	2.62
PH42	40 - 79.9	DN - 11.0	4.2	1.0	0.4	0.3	0.2	-	3.53
PH43	80 - 132.9	DN - 15.5	6.3	1.3	0.5	0.4	0.3	0.25	5.33
PH44	133 - 329.9	DN - 21.0	8.1	1.8	0.6	0.5	0.4	0.35	7.00

ORDERING EXAMPLE

Glyd Ring D for ISO groove

Series:	PH42 from Table 94
Bore Diameter:	$D_N = 63.0$ mm
TSS Part No.:	PH4200630 from Table 95

Material Z13
 Material code Z13
 O-Ring material code N
 Set code: Z13N

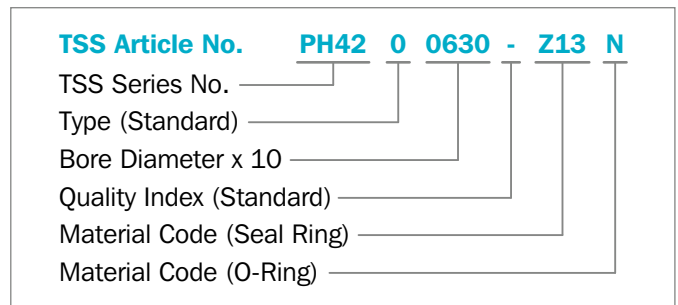

**Table 95: Installation Dimensions / TSS Part No.**

Bore Diameter	Groove Diameter	Groove Width	TSS Part No.	O-Ring Dimensions
D_N H9	d_1 h9	L_1 +0.2		
25.00	17.50	3.20	PH4100250-Z13	17.12 x 2.62
30.00	22.50	3.20	PH4100300-Z13	21.89 x 2.62
32.00	21.00	4.20	PH4200320-Z13	20.22 x 3.53
40.00	29.00	4.20	PH4200400-Z13	28.17 x 3.53
45.00	34.00	4.20	PH4200450-Z13	32.92 x 3.53
50.00	39.00	4.20	PH4200500-Z13	37.70 x 3.53
55.00	44.00	4.20	PH4200550-Z13	44.04 x 3.53
60.00	49.00	4.20	PH4200600-Z13	47.22 x 3.53
63.00	52.00	4.20	PH4200630-Z13	50.39 x 3.53
65.00	54.00	4.20	PH4200650-Z13	53.57 x 3.53
70.00	59.00	4.20	PH4200700-Z13	56.74 x 3.53
75.00	64.00	4.20	PH4200750-Z13	63.09 x 3.53
80.00	64.50	6.30	PH4300800-Z13	62.87 x 5.33
85.00	69.50	6.30	PH4300850-Z13	69.22 x 5.33
90.00	74.50	6.30	PH4300900-Z13	72.39 x 5.33
100.00	84.50	6.30	PH4301000-Z13	81.92 x 5.33
105.00	89.50	6.30	PH4301050-Z13	88.27 x 5.33
110.00	94.50	6.30	PH4301100-Z13	91.44 x 5.33
115.00	94.00	8.10	PH4401150-Z13	94.00 x 7.0
120.00	104.50	6.30	PH4301200-Z13	100.97 x 5.33
125.00	104.00	8.10	PH4401250-Z13	103.00 x 7.0
130.00	109.00	8.10	PH4401300-Z13	108.00 x 7.0
140.00	119.00	8.10	PH4401400-Z13	116.84 x 7.0
160.00	139.00	8.10	PH4401600-Z13	135.89 x 7.0
200.00	179.00	8.10	PH4402000-Z13	177.17 x 7.0
250.00	229.00	8.10	PH4402500-Z13	227.97 x 7.0

All dimensions in **bold** type are suitable for installation in grooves to ISO 7425-1, bore dia. in accordance with ISO 3320. Additional dimensions can be delivered on request.

! This page is intentionally left blank.

Zurcon® Glyd Ring P®



Double-acting

Rubber-energized plastic-faced seal

Step Cut Sealing Element

Material:

Zurcon® Polyamid + NBR



! This page is intentionally left blank.



■ Zurcon® Glyd Ring® P



■ Description

The double acting Zurcon® Glyd Ring® P is a combination of a Zurcon® based material slipper seal with a step cut and an energising rectangular elastomeric ring. It is produced with an interference fit at closed step cut which together with the squeeze of the rectangular energizer ring ensures a good sealing effect even at low pressure.

At higher system pressures, the rectangular ring is energised by the fluid, pushing the Zurcon® Glyd Ring® P against the sealing face with increased force. At high peak pressures, the Zurcon® step cut seal ring can follow ballooning of the tube without loosing the sealability.

Due to the Zurcon® high strength plastic material, two times bigger extrusion gaps are possible compared with Turcon® materials. The step cut in the ring is necessary for installation in closed grooves and for the flexibility of the seal ring due to the high stiffness of the material.

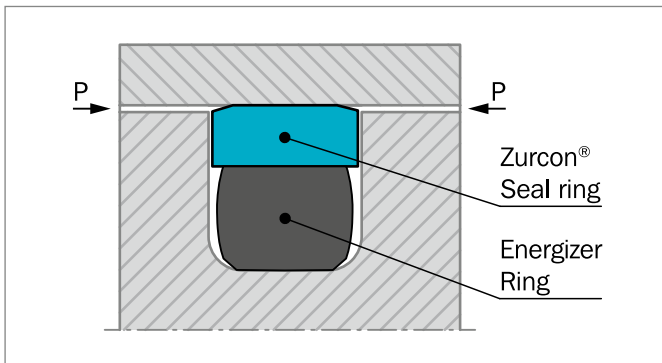

Figure 116: Zurcon® Glyd Ring® P

STEP CUT

For easy installation on the piston and for the flexibility of the seal ring a precision step cut is produced by special tool technology.

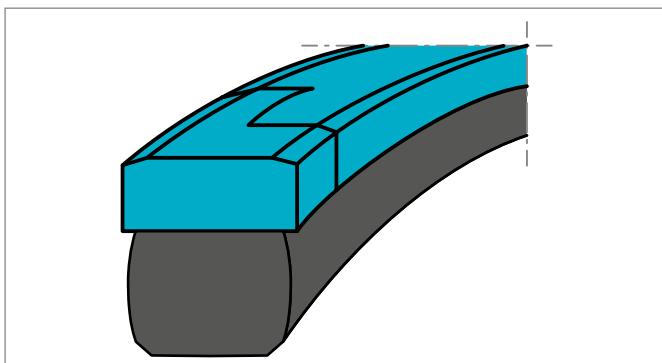

Figure 117: Step cut on Zurcon® Glyd Ring® P

ADVANTAGES

- Easy installation on piston without special tools
- Due to large extrusion gap, safe use even with soiled media
- Installation grooves acc. to ISO 7425-1
- Simple groove design, one piece piston possible
- Increased clearance compare to Turcon® Glyd Ring® seals (Approximately +50%), depending on operation conditions
- Resistent against shock loads
- High wear resistant material ensures long service life

APPLICATION EXAMPLES

- Construction machinery, e.g. excavators
- Truck cranes
- Fork lifts

It is particularly recommended for heavy duty applications.

OPERATING CONDITIONS

Zurcon® Glyd Ring® P is recommended for linear movements where the dimensional gap between piston and tube shall be as big as possible or where high pressure peaks occur during operation.

Pressure:	50 MPa standard 100 MPa pressure peak
Speed:	up to 1 m/s
Temperature:	-30 °C to +110 °C standard Special materials are available on request for applications outside this temperature range.
Media:	mineral oil based hydraulic fluids

IMPORTANT NOTE

The above data are maximum values and cannot be used at the same time, e.g. the maximum operating speed depends on material type, pressure, temperature and gap value.



MATERIALS

Standard Application:

For hydraulic components in mineral oils or medias with good lubricating performance.

Zurcon® seal ring: Zurcon® Z66

Energiser: Rectangular ring in NBR 70
shore A, code N

Set reference: Z66 N



■ Installation Recommendation

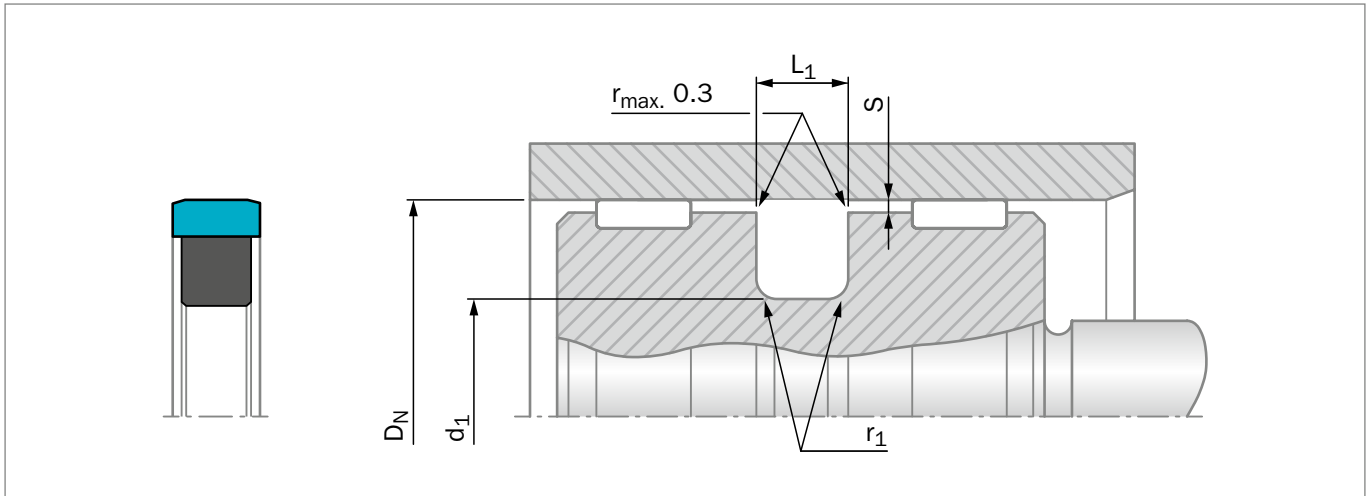

Figure 118: Installation Drawing

Table 96: Installation Dimensions

Series No.	Groove Diameter	Groove Width	Radius	Radial Clearance
	d_1 h9	$L_1 +0.2$	r_1	S_{max}
PGP2	$D_N - 11.0$	4.2	0.5	0.35
PGP3	$D_N - 15.5$	6.3	0.9	0.50
PGP4	$D_N - 21.0$	8.1	0.9	0.60

ORDERING EXAMPLE

Zurcon® Glyd Ring® P for ISO groove

Cylinder Bore Diameter:	$D_N = 125$ mm
Series No.:	PGP4 from Table 96
Part No.:	PGP401250 (from Table 97)
TSS Seal Ring Material Code:	Z66
Energizer Material Code:	N
Set Code:	Z66 N

TSS Article No.	PGP4	0	1250	-	Z66	N
Series No.	PGP4	0	1250	-	Z66	N
Type (Standard)		0				
Cylinder Bore Diameter x 10			1250			
Quality Index (Standard)					Z66	
Material Code (Seal Ring)					Z66	
Material Code (Energizer)						N

**Table 97: Preferred Series / TSS Part No.**

Bore	Groove Diameter	Groove Width	TSS Part No.
D_N H9	d_1 h9	L_1 +/-0,2	
55.0	39.5	6.3	PGP300550
60.0	49.0	4.2	PGP200600
70.0	59.0	4.2	PGP200700
70.0	54.5	6.3	PGP300700
75.0	59.5	6.3	PGP300750
75.0	54.0	8.1	PGP400750
80.0	59.0	8.1	PGP400800
90.0	74.5	6.3	PGP300900
90.0	69.0	8.1	PGP400900
95.0	74.0	8.1	PGP400950
100.0	84.5	6.3	PGP301000
100.0	79.0	8.1	PGP401000
110.0	94.5	6.3	PGP301100
110.0	89.0	8.1	PGP401100
120.0	99.0	8.1	PGP401200
125.0	109.5	6.3	PGP301250
125.0	104.0	8.1	PGP401250
130.0	109.0	8.1	PGP401300
140.0	119.0	8.1	PGP401400
150.0	129.0	8.1	PGP401500
160.0	139.0	8.1	PGP401600
170.0	149.0	8.1	PGP401700
180.0	159.0	8.1	PGP401800
190.0	169.0	8.1	PGP401900

All dimensions in **bold** are suitable for installation in grooves to ISO 7425-1, bore diameter in accordance with ISO 3320. Further sizes on request.

Turcon® AQ-Seal® 5



Double-acting

Rubber-energized plastic-faced seal

Material:

Turcon®, Zurcon® and Elastomer



! This page is intentionally left blank.



■ Turcon® AQ-Seal® 5*



■ Description

Turcon® AQ-Seal® 5 is a patented development of the proven standard Turcon® AQ-Seal®.

The particular characteristics of AQ-Seal® 5 are the seal profile with a defined seal edge and the use of two O-Rings as energizing elements to optimize the pressure profile and to reduce gas permeability.

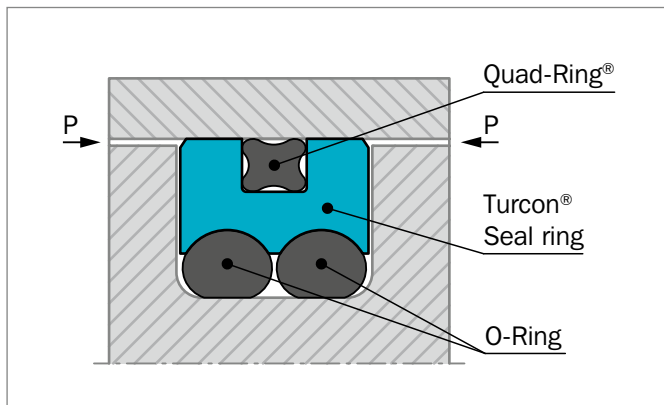

Figure 119: Turcon® AQ-Seal® 5

AQ-Seal® 5 combines the benefits of a low-friction Turcon® slipper seal with the high sealing characteristics of an elastomeric seal by incorporating a limited footprint Quad-Ring® Seal in the dynamic sealing face. This optimizes leakage control while minimizing friction.

ADVANTAGES

- High sealing effect in applications requiring media separation, e.g. fluid/fluid or fluid/gas
- Double security through the combination of low-friction special materials with elastomer seals
- Low gas permeation rate
- Higher pressure application, higher sliding speed compared to AQ-Seal®
- Outstanding sliding properties, no stick-slip effect
- Diameter from 25 to 700 mm (for sizes above use Turcon® AQ-Seal® 5 with Bean Seal, see page 431)

* Patent application: WO 90/00693 A1

APPLICATION EXAMPLES

Turcon® AQ-Seal® 5 is mainly designed for heavy duty and large diameter applications and is recommended as double acting piston seal for hydraulic equipment such as:

- Mobil hydraulics
- Cranes
- Stabilizers
- Heavy duty suspension cylinders
- Hydro-pneumatic suspensions for heavy vehicles
- Machine tools
- Presses
- Rolling mills
- Servo hydraulics
- Offshore equipment
- Cylinders with retaining function over longer periods such as jacks and support cylinders



OPERATING CONDITIONS

Pressure:	Up to 60 MPa with mineral oil Up to 25 MPa for media with low lubricating properties
Speed:	Up to 3 m/s with linear movements frequency up to 3 Hz
Temperature:	-30 °C to +200 °C* depending on seal, O-Ring and Quad-Ring® material
Media:	Mineral oil-based hydraulic fluids, flame retardant hydraulic fluids, environmentally friendly hydraulic fluids (bio-oils), phosphate ester, water and others, depending on temperature, seal, O-Ring and Quad-Ring® seal material compatibility see Table 98
Clearance:	The maximum permissible radial clearance S_{max} is shown in Table 99, as a function of the operating pressure and functional diameter.

IMPORTANT NOTE

The above data are maximum values and cannot be used at the same time, e.g. the maximum operating speed depends on material type, pressure, temperature and gap value. Temperature range also depends on media.

* In the case of unpressurized piston applications in temperatures below 0 °C please contact your local Customer Solution Center for more information!

INSTALLATION INSTRUCTIONS

AQ-Seal® 5 is installed according to information on page 247 to 249 and 251.

RECOMMENDED MATERIALS

The following material combinations have proven effective for hydraulic applications:

Turcon® AQ-Seal® 5 in Turcon® M12

All round material for light to heavy hydraulic applications with linear movements in mineral oils, flame retardant hydraulic fluids, bio-oils and phosphate ester:

O-Ring and Quad-Ring®:	NBR 70 Shore A	N
	FKM 70 Shore A	V

Set code: M12N or M12V

Turcon® AQ-Seal® 5 in Turcon® T46

For medium to heavy applications with linear movements in mineral oils and other media with good lubrication:

O-Ring and Quad-Ring®:	NBR 70 Shore A	N
	FKM 70 Shore A	V

Set code: T46N or T46V

For specific applications, all Turcon® materials are available.

Other material combinations are listed in Table 98.

**Table 98: Turcon® Materials for AQ-Seal® 5**

Material, Applications, Properties	Code	O-Ring Material Shore A***	Code	O-Ring and Quad-Ring® Operating Temp. * °C	Mating Surface Material	MPa max Dynamic
Turcon® M12 First material choice for seals in linear motion Overall improved properties For new constructions and updating For all commonly applied hydraulic fluids including fluids with low lubrication performance Lowest friction and best sliding properties Lowest wear on seals Improved absorption of abrasive contaminants Low wear or abrasion of counter surface BAM tested Mineral fiber and Additives filled Color: Dark gray	M12	NBR 70	N	-30 to +100	Steel	50
		NBR 70 Low temp.	T	-45 to +80	Steel hardened Cast iron	
		FKM 70	V	-10 to +200	Stainless steel Titanium	
Turcon® T08 For lubricating fluids and linear motion Very high compressive strength and extrusion resistance Hard counter surfaces is recommended Bronze filled Color: Light to dark brown, which may have variations in shading	T08	NBR 70	N	-30 to +100	Steel hardened	60
		NBR 70 Low temp.	T	-45 to +80	Cast iron	
		FKM 70	V	-10 to +200		
Turcon® T10 For hydraulic and pneumatic For linear motion in lubricating and non-lubricating fluids High extrusion resistance Good chemical resistance Not for electrically conducting fluids BAM tested Carbon, graphite filled Color: Black	T10	NBR 70	N	-30 to +100	Steel	40
		NBR 70 Low temp.	T	-45 to +80	Stainless steel	
		FKM 70	V	-10 to +200		
		EPDM 70	E**	-45 to +145		
Turcon® T29 For lubricating and non-lubricating fluids Good extrusion resistance Surface texture is not suitable for gas sealing Not for electrically conducting fluids Carbon fiber filled Color: Gray	T29	NBR 70	N	-30 to +100	Steel	30
		NBR 70 Low temp.	T	-45 to +80	Cast iron	
		FKM 70	V	-10 to +200	Stainless steel	
		EPDM 70	E**	-45 to +145		

Table continues on next page



Material, Applications, Properties	Code	O-Ring Material Shore A***	Code	O-Ring and Quad-Ring® Operating Temp.* °C	Mating Surface Material	MPa max Dynamic
Turcon® T40 For lubricating and non-lubricating fluids High frequency and short strokes Water hydraulics Surface texture is not suitable for gas sealing Carbon fiber filled Color: Gray	T40	NBR 70	N	-30 to +100	Steel	25
		NBR 70 Low temp.	T	-45 to +80	Cast iron Stainless steel Aluminum	
		FKM 70	V	-10 to +200		
		EPDM 70	E**	-45 to +145		
Turcon® T46 For lubricated hydraulics in linear motion High compressive strength High extrusion resistance Very good sliding and wear properties BAM tested Bronze filled Color: Light to dark brown, which may have variations in shading	T46	NBR 70	N	-30 to +100	Steel hardened	50
		NBR 70 Low temp.	T	-45 to +80	Cast iron	
		FKM 70	V	-10 to +200		
Zurcon® Z80 For lubricating and non-lubricating fluids Water based fluids, air and gases Dry air pneumatics High abrasion and extrusion resistance For service in abrasive conditions and media with particles Good chemical resistance Limited temperature capability (-60 to +80 °C) UHMWPE (Ultra High Molecular Weight Polyethylene) Color: White to off-white	Z80	NBR 70	N	-30 to (+100)	Steel	35
		NBR 70 Low temp.	T	-45 to +80	Steel hardened Stainless steel Aluminum Ceramic coating	
		EDPM 70	E**	-10 to (+145)		

* The O-Ring and Quad-Ring® Operation Temperature is only valid in mineral hydraulic oil (except EPDM).

** Material not suitable for mineral oils.

*** Quad-Ring® material NBR 70 code: N7004

FKM 70 code: V7002

BAM: Tested by "Bundesanstalt Materialprüfung, Germany".

 Highlighted materials are recommended.



■ Installation Recommendation

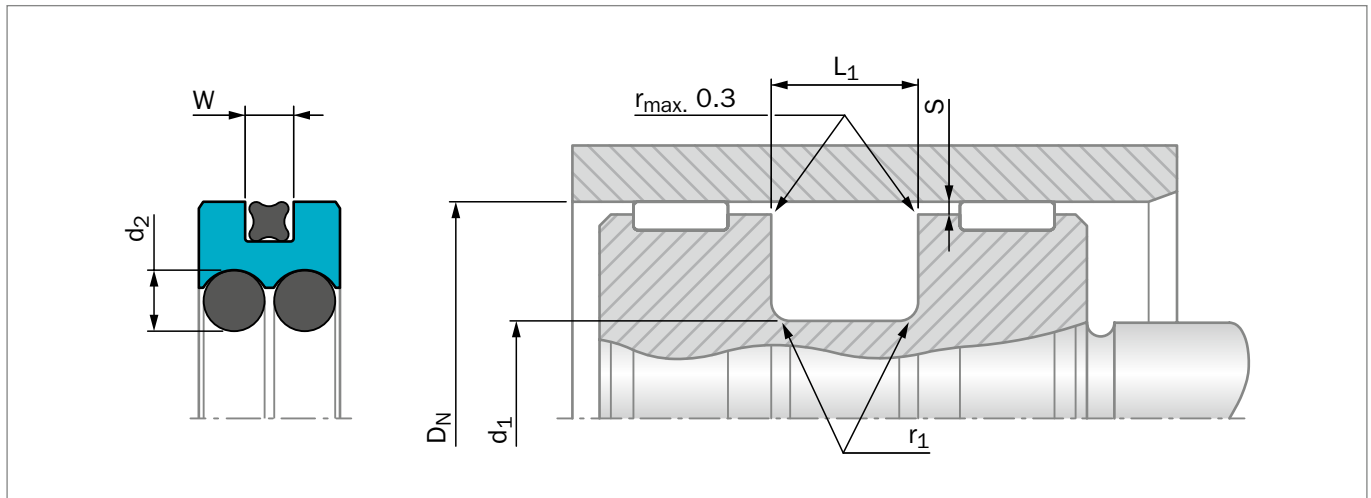

Figure 120: Installation Drawing

Table 99: Installation Dimensions

Series No.	Bore Diameter D_N H9		Groove Diameter d_1 h9	Groove Width $L_1 +0.2$	Radius r_1 max	Radial Clearance S_{max}^*			O-Ring Cross Section d_2	Quad-Ring® Cross Section W
	Standard Application	Available Range				10 MPa	20 MPa	30 MPa		
PQ010	40 - 79.9	25 - 250	$D_N - 10.0$	6.3	0.6	0.30	0.20	0.15	2.62	1.78
PQ020	80 - 132.9	50 - 275	$D_N - 13.0$	8.3	1.0	0.40	0.30	0.15	3.53	2.62
PQ030	133 - 462.9	100 - 480	$D_N - 18.0$	12.3	1.3	0.40	0.30	0.20	5.33	3.53
PQ040	463 - 700.0	425 - 700	$D_N - 31.0$	16.3	1.8	0.50	0.40	0.30	7.00	5.33

* At pressures > 30 MPa use diameter tolerance H8/f8 (bore/piston) in the area of the seal use Turcon® AQ-Seal® 5 CR or consult your local Customer Solution Center for alternative material or profiles.

Slydring® / Wear Rings are not applicable at very small radial clearances please consult the Slydring® section in this catalog.

ORDERING EXAMPLE

Turcon® AQ-Seal® 5 complete with Quad-Ring® and O-Rings, standard application:

Series: PQ020 from Table 99

Bore Diameter: $D_N = 80.0$ mm

TSS Part No.: PQ0200800 from Table 100

Select the material from Table 98. The corresponding code numbers are appended to the TSS Part No. Together they form the TSS Article Number. The TSS Article Number for all intermediate sizes can be determined by following the example:

TSS Article No. **PQ02 0 0800 - M12 N**

TSS Series No. _____

Type (Standard) _____

Bore Diameter x 10 _____

Quality Index (Standard) _____

Material Code (Seal Ring) _____

Material Code (O-Ring)/(Quad-Ring® Seal) _____



Table 100: Installation Dimensions / TSS Part No.

Bore	Groove Diameter	Groove Width	Part No.	O-Ring Size	Quad-Ring® Size
D _N H9	d ₁ h9	L ₁ +0.2			
40.0	30.0	6.3	PQ0100400	29.82 x 2.62	34.65 x 1.78
42.0	32.0	6.3	PQ0100420	31.42 x 2.62	37.82 x 1.78
45.0	35.0	6.3	PQ0100450	34.59 x 2.62	37.82 x 1.78
48.0	38.0	6.3	PQ0100480	37.77 x 2.62	41.00 x 1.78
50.0	40.0	6.3	PQ0100500	39.34 x 2.62	44.17 x 1.78
52.0	42.0	6.3	PQ0100520	40.94 x 2.62	47.35 x 1.78
55.0	45.0	6.3	PQ0100550	44.12 x 2.62	50.52 x 1.78
60.0	50.0	6.3	PQ0100600	48.90 x 2.62	53.70 x 1.78
63.0	53.0	6.3	PQ0100630	52.07 x 2.62	56.87 x 1.78
65.0	55.0	6.3	PQ0100650	53.64 x 2.62	60.05 x 1.78
70.0	60.0	6.3	PQ0100700	58.42 x 2.62	63.22 x 1.78
75.0	65.0	6.3	PQ0100750	63.17 x 2.62	69.57 x 1.78
80.0	67.0	8.3	PQ0200800	66.27 x 3.53	71.12 x 2.62
85.0	72.0	8.3	PQ0200850	69.44 x 3.53	75.87 x 2.62
90.0	77.0	8.3	PQ0200900	75.79 x 3.53	82.22 x 2.62
95.0	82.0	8.3	PQ0200950	78.97 x 3.53	82.22 x 2.62
100.0	87.0	8.3	PQ0201000	85.32 x 3.53	88.57 x 2.62
105.0	92.0	8.3	PQ0201050	91.67 x 3.53	94.92 x 2.62
110.0	97.0	8.3	PQ0201100	94.84 x 3.53	101.27 x 2.62
115.0	102.0	8.3	PQ0201150	101.19 x 3.53	107.62 x 2.62
120.0	107.0	8.3	PQ0201200	104.37 x 3.53	107.62 x 2.62
125.0	112.0	8.3	PQ0201250	110.72 x 3.53	113.97 x 2.62
130.0	117.0	8.3	PQ0201300	113.89 x 3.53	120.32 x 2.62
135.0	117.0	12.3	PQ0301350	113.67 x 5.33	123.42 x 3.53
140.0	122.0	12.3	PQ0301400	120.02 x 5.33	126.59 x 3.53
150.0	132.0	12.3	PQ0301500	129.54 x 5.33	136.12 x 3.53
160.0	142.0	12.3	PQ0301600	139.07 x 5.33	145.64 x 3.53
170.0	152.0	12.3	PQ0301700	148.49 x 5.33	158.34 x 3.53
180.0	162.0	12.3	PQ0301800	158.12 x 5.33	164.69 x 3.53
190.0	172.0	12.3	PQ0301900	170.82 x 5.33	177.39 x 3.53
200.0	182.0	12.3	PQ0302000	177.17 x 5.33	183.74 x 3.53
210.0	192.0	12.3	PQ0302100	189.87 x 5.33	196.44 x 3.53
220.0	202.0	12.3	PQ0302200	196.22 x 5.33	202.79 x 3.53
230.0	212.0	12.3	PQ0302300	208.92 x 5.33	215.49 x 3.53
240.0	222.0	12.3	PQ0302400	221.62 x 5.33	221.84 x 3.53
250.0	232.0	12.3	PQ0302500	227.97 x 5.33	234.54 x 3.53
280.0	262.0	12.3	PQ0302800	253.37 x 5.33	266.29 x 3.53
300.0	282.0	12.3	PQ0303000	278.77 x 5.33	278.99 x 3.53
320.0	302.0	12.3	PQ0303200	291.47 x 5.33	304.39 x 3.53
350.0	332.0	12.3	PQ0303500	329.57 x 5.33	329.79 x 3.53



Bore	Groove Diameter	Groove Width	Part No.	O-Ring Size	Quad-Ring® Size
D_N H9	d_1 h9	L_1 +0.2			
400.0	382.0	12.3	PQ0304000	380.37 x 5.33	380.59 x 3.53
420.0	402.0	12.3	PQ0304200	405.26 x 5.33	380.59 x 3.53
450.0	432.0	12.3	PQ0304500	430.66 x 5.33	430.66 x 3.53
480.0	449.0	16.3	PQ0404800	443.36 x 7.00	456.06 x 5.33
500.0	469.0	16.3	PQ0405000	468.76 x 7.00	456.06 x 5.33
600.0	569.0	16.3	PQ0406000	557.66 x 7.00	557.58 x 5.33
700.0	669.0	16.3	PQ0407000	658.88 x 7.00	658.88 x 5.33

Bore diameters in **bold** type comply with the recommendations of ISO 3320.

All intermediate sizes up to 700 mm diameter can be supplied. Sizes > 700 mm diameter with special elastomers on request, see Turcon® AQ-Seal® with Bean Seal page 431

! This page is intentionally left blank.

Turcon® AQ-Seal®



Double-acting

Rubber-energized plastic-faced seal

Material:

Turcon®, Zurcon® and Elastomer



! This page is intentionally left blank.



■ Turcon® AQ-Seal®



■ Description

Turcon® AQ-Seal® is a double-acting seal consisting of a seal ring of Turcon® material, an Quad-Ring® seal and an O-Ring as energizing element.

The Turcon® seal ring and the Quad-Ring® Seal together create the dynamic sealing function while the O-Ring performs the static sealing function.

AQ-Seal® is supplied as standard with radial notches on both sides which ensure direct pressurizing of the seal under all operating conditions.

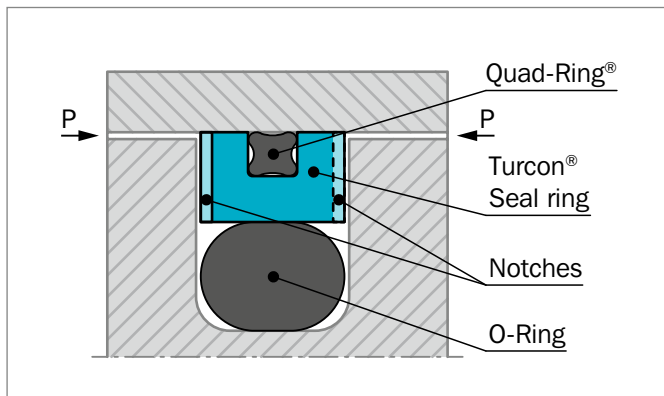

Figure 121: Turcon® AQ-Seal®

AQ-Seal® combines the benefits of a low-friction Turcon® slipper seal with the high sealing characteristics of an elastomeric seal by incorporating a limited foot print Quad-Ring® in the dynamic sealing face. This optimizes leakage control while minimizing friction.

ADVANTAGES

- High sealing effect in applications requiring media separation, e.g. fluid/fluid or fluid/gas
- Double security through the combination of low-friction special materials with elastomer seals
- Simple groove design, small installation space, interchangeable with Turcon® Glyd Ring® and Turcon® Glyd Ring® T installation according to ISO 7425-1
- Outstanding sliding properties, no stick-slip effect
- Diameter from 15 to 700 mm (for sizes above use Turcon® AQ-Seal® with Bean Seal, see page 431)

APPLICATION EXAMPLES

AQ-Seal® is the recommended sealing element for double acting pistons of positioning and holding cylinders for:

- Mobile hydraulics
- Machine tools
- Presses
- Semi-static piston accumulators
- Active stabilizers
- Hydro-pneumatic suspensions for heavy vehicles
- Subsea connectors
- Offshore valves
- Wind Power
- Pressure intensifiers
- Jacks
- Lifts
- Hydraulic vices



OPERATING CONDITIONS

Pressure:	Up to 50 MPa with mineral oil Up to 30 MPa for media with reduced lubricating properties
Speed:	Up to 2 m/s with reciprocating movements
Temperature:	-45 °C to +200 °C* depending on O-Ring and Quad-Ring® seal material
Media:	Mineral oil-based hydraulic fluids, flame retardant hydraulic fluids, environmentally friendly hydraulic fluids (bio-oils), phosphate ester, water and others, depending on temperature, seal, O-Ring and Quad-Ring® seal material compatibility see Table 101
Clearance:	The maximum permissible radial clearance S_{max} is shown in Table 102, as a function of the operating pressure and functional diameter.

IMPORTANT NOTE

The above data are maximum values and cannot be used at the same time, e.g. the maximum operating speed depends on material type, pressure, temperature and gap value. Temperature range also depends on media.

* In the case of unpressurized applications in temperatures below 0 °C please contact your local Customer Solution Center for more information!

INSTALLATION INSTRUCTIONS

AQ-Seal® is installed according to information on page 247 to 249 and 251.

Closed groove installation applies same dimensions as for Turcon® Glyd Ring® in Table 80 page 249.

RECOMMENDED MATERIALS

The following material combinations have proven effective for hydraulic applications:

Turcon® AQ-Seal® in Turcon® M12

All round material for light to heavy hydraulic applications with linear, movements in mineral oils, flame retardant hydraulic fluids, phosphate ester, bio-oils or fluids having low lubricating properties:

O-Ring and Quad-Ring®:	NBR 70 Shore A	N
	FKM 70 Shore A	V
Set code:	M12N or M12V	

Turcon® AQ-Seal® in Turcon® T46

For medium to heavy applications with linear movements in mineral oils and other media with good lubrication:

O-Ring and Quad-Ring®:	NBR 70 Shore A	N
	FKM 70 Shore A	V
Set code:	T46N or T46V	

For specific applications, all Turcon® materials are available.

Other material combinations are listed in Table 101.

**Table 101: Turcon® Material for AQ-Seal®**

Material, Applications, Properties	Code	O-Ring Material Shore A***	Code	O-Ring and Quad-Ring® Operating Temp.* °C	Mating Surface Material	MPa max Dynamic
Turcon® M12 First material choice for seals in linear motion Overall improved properties For new constructions and updating For all commonly applied hydraulic fluids Low wear or abrasion of counter surface including fluids with low lubrication performance Lowest friction and best sliding properties Lowest wear on seals Improved absorption of abrasive contaminants BAM tested Mineral fiber and Additives filled Color: Dark gray	M12	NBR 70	N	-30 to +100	Steel	40
		NBR 70 Low temp.	T	-45 to +80	Steel hardened Cast iron Stainless steel	
		FKM 70	V	-10 to +200	Titanium	
Turcon® T08 For lubricating fluids and linear motion Very high compressive strength and extrusion resistance Hard counter surfaces is recommended Bronze filled Color: Light to dark brown, which may have variations in shading	T08	NBR 70	N	-30 to +100	Steel hardened	50
		NBR 70 Low temp.	T	-45 to +80	Cast iron	
		FKM 70	V	-10 to +200		
Turcon® T10 For hydraulic and pneumatic For linear motion in lubricating and non-lubricating fluids High extrusion resistance Good chemical resistance Not for electrically conducting fluids BAM tested Carbon, graphite filled Color: Black	T10	NBR 70	N	-30 to +100	Steel	30
		NBR 70 Low temp.	T	-45 to +80	Stainless steel	
		FKM 70	V	-10 to +200		
		EPDM 70	E**	-45 to +145		
Turcon® T29 For lubricating and non-lubricating fluids Good extrusion resistance Surface texture is not suitable for gas sealing Not for electrically conducting fluids Carbon fiber filled Color: Gray	T29	NBR 70	N	-30 to +100	Steel	30
		NBR 70 Low temp.	T	-45 to +80	Cast iron Stainless steel	
		FKM 70	V	-10 to +200		
		EPDM 70	E**	-45 to +145		

Table continues on next page



■ Installation Recommendation

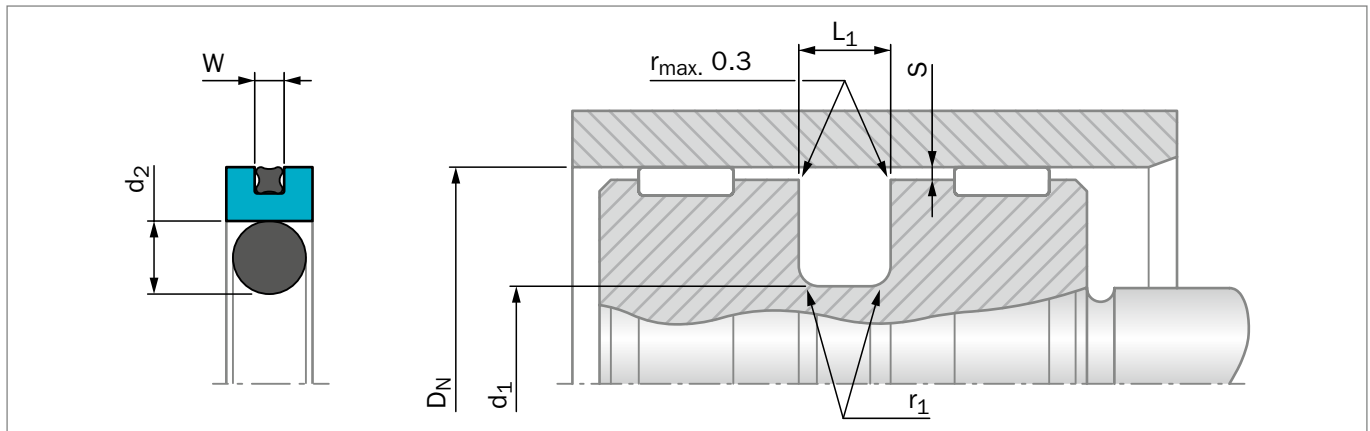

Figure 122: Installation Drawing

Table 102: Installation Dimensions

Bore Diameter D_N H9				Groove Diameter	Groove Width	Radius	Radial Clearance S_{max}^*			O-Ring Cross Section	Quad-Ring® Cross Section
Standard Application		Light Application					d_1 h9	$L_1 +0.2$	r_1 max		
Series No.	Diameter Range	Series No.	Diameter Range	d_2	W						
PQ12	15 - 39.9	PQ14	40 - 79.9	$D_N - 11.0$	4.2	1.0	0.25	0.15	0.10	3.53	1.78
PQ12	40 - 79.9	PQ14	80 - 132.9	$D_N - 15.5$	6.3	1.3	0.30	0.20	0.15	5.33	1.78
PQ22	80 - 132.9	PQ24	133 - 252.9	$D_N - 21.0$	8.1	1.8	0.30	0.20	0.15	7.00	2.62
PQ22	133 - 252.9	-	-	$D_N - 24.5$	8.1	1.8	0.30	0.20	0.15	7.00	2.62
PQ32	253 - 462.9	-	-	$D_N - 28.0$	9.5	2.5	0.45	0.30	0.25	8.40	3.53
PQ52	463 - 700.0	-	-	$D_N - 35.0$	11.5	3.0	0.55	0.40	0.35	10.00	5.33

* At pressures > 40 MPa use diameter tolerance H8/f8 (bore/rod) in the area of the seal use Turcon® AQ-Seal® 5 CR or consult your local Customer Solution Center for alternative material or profiles.
Slydring® / Wear Rings are not applicable at very small radial clearances please consult the Slydring® section in this catalog.

ORDERING EXAMPLE

AQ-Seal® complete with Quad-Ring® and O-Ring standard application:

Series:	PQ22 from Table 102
Bore Diameter:	$D_N = 80.0$ mm
TSS Part No.	PQ2200800 from Table 103

Select the material from Table 101. The corresponding code numbers are appended to the TSS Part No. Together they form the TSS Article Number. The TSS Article Number for all intermediate sizes can be determined by following the example:

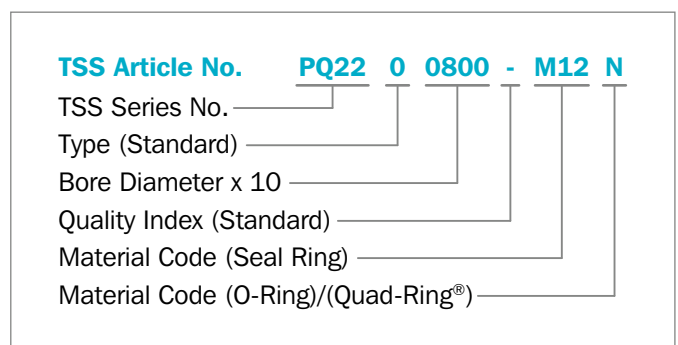



Table 103: Installation Dimensions / TSS Part No.

Bore	Groove Diameter	Groove Width	Part No.	O-Ring Size	Quad-Ring® Size
D _N H9	d ₁ h9	L ₁ +0.2			
16.0	5.0	4.2	PQ1200160	4.34 x 3.53	12.42 x 1.78
18.0	7.0	4.2	PQ1200180	6.40 x 3.53	14.00 x 1.78
20.0	9.0	4.2	PQ1200200	8.40 x 3.53	15.60 x 1.78
22.0	11.0	4.2	PQ1200220	10.69 x 3.53	17.17 x 1.78
25.0	14.0	4.2	PQ1200250	13.87 x 3.53	20.35 x 1.78
28.0	17.0	4.2	PQ1200280	15.47 x 3.53	23.52 x 1.78
30.0	19.0	4.2	PQ1200300	18.66 x 3.53	25.12 x 1.78
32.0	21.0	4.2	PQ1200320	20.22 x 3.53	26.70 x 1.78
35.0	24.0	4.2	PQ1200350	23.40 x 3.53	29.87 x 1.78
40.0	29.0	4.2	PQ1400400	28.17 x 3.53	34.65 x 1.78
42.0	31.0	4.2	PQ1400420	29.75 x 3.53	37.82 x 1.78
45.0	34.0	4.2	PQ1400450	32.92 x 3.53	37.82 x 1.78
48.0	37.0	4.2	PQ1400480	36.09 x 3.53	41.00 x 1.78
50.0	39.0	4.2	PQ1400500	37.69 x 3.53	44.17 x 1.78
50.0	34.5	6.3	PQ1200500	32.69 x 5.33	44.17 x 1.78
52.0	41.0	4.2	PQ1400520	40.87 x 3.53	47.35 x 1.78
55.0	44.0	4.2	PQ1400550	44.04 x 3.53	50.52 x 1.78
60.0	49.0	4.2	PQ1400600	47.22 x 3.53	53.70 x 1.78
63.0	52.0	4.2	PQ1400630	50.39 x 3.53	56.87 x 1.78
63.0	47.5	6.3	PQ1200630	46.99 x 5.33	56.87 x 1.78
65.0	54.0	4.2	PQ1400650	53.57 x 3.53	60.05 x 1.78
70.0	59.0	4.2	PQ1400700	56.74 x 3.53	63.22 x 1.78
70.0	54.5	6.3	PQ1200700	53.34 x 5.33	63.22 x 1.78
75.0	64.0	4.2	PQ1400750	63.09 x 3.53	69.57 x 1.78
80.0	64.5	6.3	PQ1400800	62.87 x 5.33	72.75 x 1.78
80.0	59.0	8.1	PQ2200800	58.00 x 7.00	71.12 x 2.62
85.0	69.5	6.3	PQ1400850	69.22 x 5.33	75.92 x 1.78
85.0	64.0	8.1	PQ2200850	63.00 x 7.00	75.87 x 2.62
90.0	74.5	6.3	PQ1400900	72.39 x 5.33	82.27 x 1.78
90.0	69.0	8.1	PQ2200900	68.00 x 7.00	82.22 x 2.62
95.0	79.5	6.3	PQ1400950	78.74 x 5.33	88.62 x 1.78
95.0	74.0	8.1	PQ2200950	73.00 x 7.00	82.22 x 2.62
100.0	84.5	6.3	PQ1401000	81.92 x 5.33	88.62 x 1.78
100.0	79.0	8.1	PQ2201000	78.00 x 7.00	88.57 x 2.62
105.0	89.5	6.3	PQ1401050	88.27 x 5.33	94.97 x 1.78
105.0	84.0	8.1	PQ2201050	83.00 x 7.00	94.92 x 2.62
110.0	94.5	6.3	PQ1401100	91.44 x 5.33	101.32 x 1.78
110.0	89.0	8.1	PQ2201100	88.00 x 7.00	101.27 x 2.62
115.0	99.5	6.3	PQ1401150	97.79 x 5.33	107.67 x 1.78
115.0	94.0	8.1	PQ2201150	93.00 x 7.00	107.62 x 2.62



Bore	Groove Diameter	Groove Width	Part No.	O-Ring Size	Quad-Ring® Size
D_N H9	d_1 h9	L_1 +0.2			
120.0	104.5	6.3	PQ1401200	100.97 x 5.33	114.02 x 1.78
120.0	99.0	8.1	PQ2201200	98.00 x 7.00	107.62 x 2.62
125.0	109.5	6.3	PQ1401250	107.32 x 5.33	114.02 x 1.78
125.0	104.0	8.1	PQ2201250	103.00 x 7.00	113.97 x 2.62
130.0	114.5	6.3	PQ1401300	113.67 x 5.33	120.37 x 1.78
130.0	109.0	8.1	PQ2201300	108.00 x 7.00	120.32 x 2.62
135.0	114.0	8.1	PQ2401350	113.67 x 7.00	126.67 x 2.62
140.0	119.0	8.1	PQ2401400	116.84 x 7.00	126.67 x 2.62
150.0	129.0	8.1	PQ2401500	126.37 x 7.00	139.37 x 2.62
160.0	139.0	8.1	PQ2401600	135.89 x 7.00	145.72 x 2.62
170.0	149.0	8.1	PQ2401700	145.42 x 7.00	158.42 x 2.62
180.0	159.0	8.1	PQ2401800	158.12 x 7.00	171.12 x 2.62
190.0	169.0	8.1	PQ2401900	164.47 x 7.00	177.47 x 2.62
200.0	179.0	8.1	PQ2402000	177.17 x 7.00	190.17 x 2.62
210.0	189.0	8.1	PQ2402100	183.52 x 7.00	196.52 x 2.62
220.0	199.0	8.1	PQ2402200	196.22 x 7.00	202.87 x 2.62
230.0	209.0	8.1	PQ2402300	202.57 x 7.00	215.57 x 2.62
240.0	219.0	8.1	PQ2402400	215.27 x 7.00	221.92 x 2.62
250.0	225.5	8.1	PQ2202500	227.97 x 7.00	234.62 x 2.62
250.0	229.0	8.1	PQ2402500	227.97 x 7.00	234.62 x 2.62
280.0	252.0	9.5	PQ3202800	250.00 x 8.40	266.29 x 3.53
300.0	272.0	9.5	PQ3203000	270.00 x 8.40	278.99 x 3.53
310.0	282.0	9.5	PQ3203100	280.00 x 8.40	291.69 x 3.53
320.0	292.0	9.5	PQ3203200	304.00 x 8.40	304.39 x 3.53
350.0	322.0	9.5	PQ3203500	330.00 x 8.40	329.79 x 3.53
400.0	372.0	9.5	PQ3204000	370.00 x 8.40	380.59 x 3.53
420.0	392.0	9.5	PQ3204200	390.00 x 8.40	380.59 x 3.53
450.0	422.0	9.5	PQ3204500	420.00 x 8.40	430.66 x 3.53
480.0	445.0	11.5	PQ5204800	444.00 x 10.00	456.06 x 5.33
500.0	465.0	11.5	PQ5205000	464.00 x 10.00	456.06 x 5.33
600.0	565.0	11.5	PQ5206000	564.00 x 10.00	557.58 x 5.33
700.0	665.0	11.5	PQ5207000	664.00 x 10.00	658.88 x 5.33

The dimensions in **bold** type are suitable for grooves to ISO 7425-1. Bore diameter in accordance with ISO 3320.

All intermediate sizes up to 700 mm diameter can be supplied. Sizes > 700 mm diameter with special elastomers on request, see Turcon® AQ-Seal® with Bean Seal page 431.

! This page is intentionally left blank.

Turcon® Stepseal® 2K



Single-acting

Rubber-energized plastic-faced seal

Material:

Turcon®, Zurcon® and Elastomer



! This page is intentionally left blank.



Turcon® Stepseal® 2K*



Description

Stepseal® 2K is a single-acting seal element consisting of a seal ring of high-grade Turcon® or Zurcon® materials and an O-Ring as energizing element.

Stepseal® 2K was originally developed and patented by Trelleborg Sealing Solutions as a rod seal. Due to its outstanding properties it is well suited as a single-acting piston seal where high demands are made on positional accuracy and free movement.

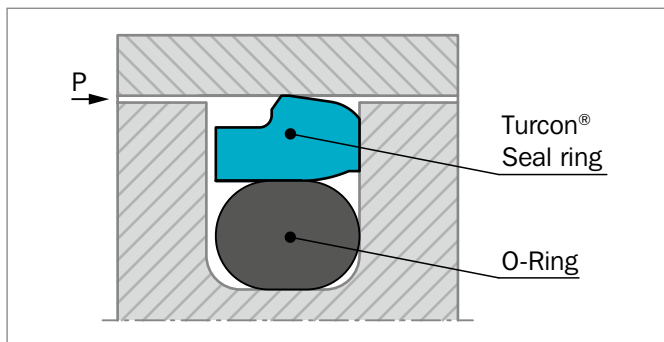

Figure 123: Turcon® Stepseal® 2K

ADVANTAGES

- High static and dynamic sealing effect
- Low friction, high efficiency
- Stick-slip free operation
- High extrusion resistance allowing large hardware clearances
- High abrasion resistance
- Long service life
- Simple groove design, one-piece piston possible
- Wide range of application temperatures and high resistance to chemicals, depending on the choice of O-Ring material
- Simple installation without seal edge deformation
- Available for all diameters up to 2,700 mm

APPLICATION EXAMPLES

Turcon® Stepseal® 2K is the recommended sealing element for single acting pistons in hydraulic components for:

- Mobile hydraulics

- Construction Equipment

- Injection molding machines

- Machine tools

- Presses

- Cranes

- Servo hydraulics

- Automotive industry

OPERATING CONDITIONS

Pressure:	Up to 60 MPa
Speed:	Up to 15 m/s, with reciprocating movements, frequency up to 5 Hz
Temperature:	-45 °C to +200 °C**
Media:	Mineral oil-based hydraulic fluids, flame retardant hydraulic fluids, environmentally friendly hydraulic fluids (bio-oils), phosphate ester, water and others, depending on the seal and O-Ring material compatibility see Table 105
Clearance:	The maximum permissible radial clearance S_{max} is shown in Table 106, as a function of the operating pressure and functional diameter.

IMPORTANT NOTE

The above data are maximum values and cannot be used at the same time, e.g. the maximum operating speed depends on material type, pressure, temperature and gap value. Temperature range also depends on media.

** In the case of unpressurized piston applications in temperatures below 0 °C please contact your local Customer Solution Center for more information!

* Patent application: WO 00/75539 A1



SERIES

Different cross section sizes are recommended as a function of the seal diameters.

Table 104 shows the relationship between the series number according to the seal diameter range and the different application class sizes. These application classes are:

Standard application:	General applications without no exceptional operating conditions.
Light application:	Applications with demands for reduced friction or for smaller grooves.
Heavy-duty application:	For exceptional operating loads such as high pressures, pressure peaks, etc.

Table 104: Available Range

Series No.	Bore Diameter D _N H9
PSK00	6.0 - 140.0
PSK10	10.0 - 140.0
PSK20	12.0 - 320.0
PSK30	18.0 - 480.0
PSK40	50.0 - 700.0
PSK80	133.0 - 999.9
PSK50	250.0 - 999.9
PSK5X	1,000.0 - 1,200.0
PSK60	670.0 - 999.9
PSK6X	1,000.0 - 2,700.0

For the recommended Standard Application range see Table 106.

ISO GROOVE

Stepseal® 2K is installed in Trelleborg Sealing Solutions standard Stepseal® grooves or according to ISO 7425-1 seal housing.

INSTALLATION INSTRUCTIONS

Stepseal® 2K is installed according to information on page 247 to 249.

Closed groove installation according to dimensions in Table 80 page 249.



RECOMMENDED MATERIALS

The following material combinations have proven effective for hydraulic applications:

Turcon® Stepseal® 2K in Turcon® M12

All round material for light to heavy hydraulic applications with linear, short stroke or helical movements in mineral oils, flame retardant hydraulic fluids, phosphate ester, bio-oils or fluids having low lubricating properties:

O-Ring: NBR 70 Shore A N
 FKM 70 Shore A V

Set code: M12N or M12V

Turcon® Stepseal® 2K in Turcon® T46

For medium to heavy applications with linear movements in mineral oils and other media with good lubrication:

O-Ring: NBR 70 Shore A N
 FKM 70 Shore A V

Set code: T46N or T46V

For specific applications, all Turcon® materials are available.

Other material combinations are listed in Table 105.



Table 105: Turcon® and Zurcon® Materials for Stepseal® 2K

Material, Applications, Properties	Code	O-Ring Material Shore A	Code	O-Ring Operating Temp.* °C	Mating Surface Material	MPa max. Dynamic
Turcon® M12 First material choice for seals in linear motion Overall improved properties For new constructions and updating For all commonly applied hydraulic fluids including fluids with low lubrication performance Lowest friction and best sliding properties Lowest wear on seals Improved absorption of abrasive contaminants Low wear or abrasion of counter surface BAM tested Mineral fiber and Additives filled Color: Dark gray	M12	NBR 70	N	-30 to +100	Steel	50
		NBR 70 Low temp.	T	-45 to +80	Steel hardened Cast iron	
		FKM 70	V	-10 to +200	Stainless steel Titanium	
Turcon® T05 For lubricating fluids Also for gas service Very low friction Very good sliding and sealing properties Color: Turquoise	T05	NBR 70	N	-30 to +100	Steel	20
		NBR 70 Low temp.	T	-45 to +80	Steel hardened	
		FKM 70	V	-10 to +200		
Turcon® T08 For lubricating fluids and linear motion Very high compressive strength and extrusion resistance Hard counter surfaces is recommended Bronze filled Color: Light to dark brown, which may have variations in shading	T08	NBR 70	N	-30 to +100	Steel hardened	60
		NBR 70 Low temp.	T	-45 to +80	Cast iron	
		FKM 70	V	-10 to +200		
Turcon® T10 For hydraulic and pneumatic For lubricating and non-lubricating fluids High extrusion resistance Good chemical resistance Not for electrically conducting fluids BAM tested Carbon, graphite filled Color: Black	T10	NBR 70	N	-30 to +100	Steel	40
		NBR 70 Low temp.	T	-45 to +80	Steel hardened Stainless steel	
		FKM 70	V	-10 to +200		
		EPDM 70	E**	-45 to +145		
Turcon® T29 For lubricating and non-lubricating fluids Good extrusion resistance Surface texture is not suitable for gas sealing Not for electrically conducting fluids Carbon fiber filled Color: Gray	T29	NBR 70	N	-30 to +100	Steel	30
		NBR 70 Low temp.	T	-45 to +80	Steel hardened Cast iron Stainless steel	
		FKM 70	V	-10 to +200		
		EPDM 70	E**	-45 to +145		

Table continues on next page



Material, Applications, Properties	Code	O-Ring Material Shore A	Code	O-Ring Operating Temp.* °C	Mating Surface Material	MPa max. Dynamic
Turcon® T40 For lubricating and non-lubricating fluids High frequency and short strokes Water hydraulics Surface texture is not suitable for gas sealing Carbon fiber filled Color: Gray	T40	NBR 70	N	-30 to +100	Steel	25
		NBR 70 Low temp.	T	-45 to +80	Steel hardened Cast iron	
		FKM 70	V	-10 to +200	Stainless steel	
		EPDM 70	E**	-45 to +145	Aluminum	
Turcon® T46 For lubricated hydraulics in linear motion High compressive strength High extrusion resistance Very good sliding and wear properties BAM tested Bronze filled Color: Light to dark brown, which may have variations in shading	T46	NBR 70	N	-30 to +100	Steel hardened	50
		NBR 70 Low temp.	T	-45 to +80	Cast iron	
		FKM 70	V	-10 to +200		
Zurcon® Z53*** For mineral oil based fluids Very high abrasion and extrusion resistance For counter surface with rougher surface finish Limited chemical resistance Max. working temperature 110 °C Cast polyurethane Color: Yellow to light-brown	Z53	NBR 70	N	-30 to +100	Steel	60
		NBR 70 Low temp.	T	-45 to +80	Steel hardened Steel chrome plated (rod) Cast iron Stainless steel Ceramic coating	
Zurcon® Z80 For lubricating and non-lubricating fluids Water based fluids, air and gases Dry air pneumatics High abrasion and extrusion resistance For service in abrasive conditions and media with particles Good chemical resistance Limited temperature capability (-60 to +80 °C) UHMWPE (Ultra High Molecular Weight Polyethylene) Color: White to off-white	Z80	NBR 70	N	-30 to (+100)	Steel	35
		NBR 70 Low temp.	T	-45 to +80	Steel hardened Stainless steel	
		EPDM 70	E**	-45 to (+145)	Aluminum Ceramic coating	

* The O-Ring Operation Temperature is only valid in mineral hydraulic oil (except EPDM).

** Material not suitable for mineral oils.

*** Max. diameter 2,300 mm

BAM: Tested by "Bundesanstalt Materialprüfung, Germany".

Highlighted materials are recommended.



Installation Recommendation

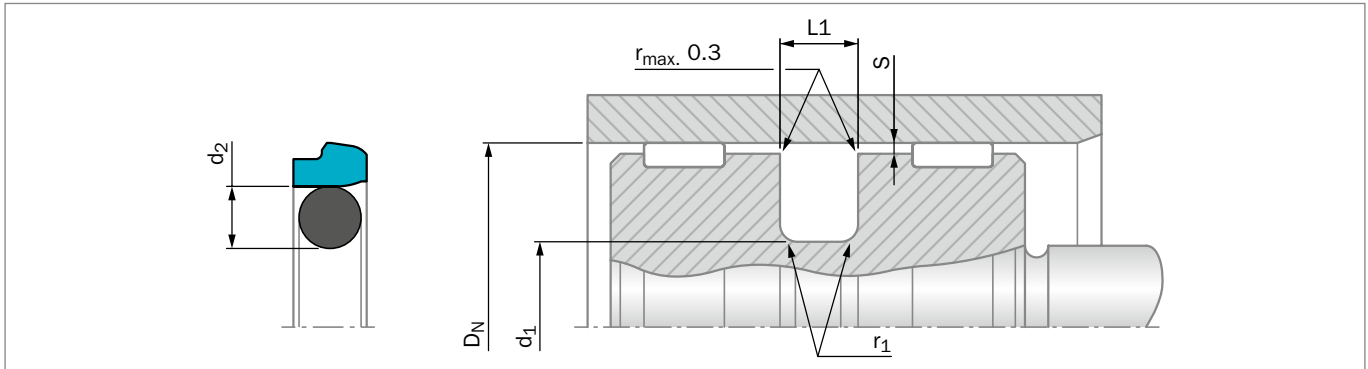

Figure 124: Installation Drawing

Table 106: Installation Dimensions - Standard Recommendations

Series No.	Bore Diameter D_N H9			Groove Diameter d_1 h9	Groove Width L_1 +0.2	Radius r_1 max	Radial Clearance S_{max}^*			O-Ring Cross Section d_2
	Standard Application	Light Application	Heavy-Duty Application				10 MPa	20 MPa	40 MPa	
PSK0	8 - 16.9	17 - 26.9	-	$D_N - 4.9$	2.2	0.4	0.30	0.20	0.15	1.78
PSK1	17 - 26.9	27 - 59.9	-	$D_N - 7.3$	3.2	0.6	0.40	0.25	0.15	2.62
PSK2	27 - 59.9	60 - 199.9	17 - 24.9	$D_N - 10.7$	4.2	1.0	0.50	0.30	0.20	3.53
PSK3	60 - 199.9	200 - 255.9	25 - 59.9	$D_N - 15.1$	6.3	1.3	0.70	0.40	0.25	5.33
PSK4	200 - 255.9	256 - 669.9	60 - 199.9	$D_N - 20.5$	8.1	1.8	0.80	0.60	0.35	7.00
PSK8	256 - 669.9	670 - 999.9	200 - 255.9	$D_N - 24.0$	8.1	1.8	0.90	0.70	0.40	7.00
PSK5	670 - 999.9	-	256 - 669.9	$D_N - 27.3$	9.5	2.5	1.00	0.80	0.60	8.40
PSK5X	-	1,000 - 1,200	-	$D_N - 27.3$	9.5	2.5	1.00	0.80	0.60	8.40
PSK6**	-	-	670 - 999.9	$D_N - 38.0$	13.8	3.0	1.20	0.90	0.60	12.00
PSK6X**	1,000 - 2,700	-	-	$D_N - 38.0$	13.8	3.0	1.20	0.90	0.60	12.00

* At pressures > 40 MPa use diameter tolerance H8/f8 (bore/piston) in the area behind seal or consult your local Customer Solution Center for alternative material or profiles.

Slydring® / Wear Rings are not applicable at very small radial clearances please consult the Slydring® section in this catalog.

** O-Rings with 12 mm cross section are delivered as special profile ring

ORDERING EXAMPLE

Turcon® Stepseal® 2K complete with O-Ring, standard application:

Series:	PSK3 from Table 106
Bore Diameter:	$D_N = 80.0$ mm
TSS Part No.:	PSK300800 from Table 107

Select the material from Table 105. The corresponding code numbers are appended to the TSS Part No. Together these form the TSS Article Number. The TSS Article Number for all intermediate sizes can be determined by following the example:

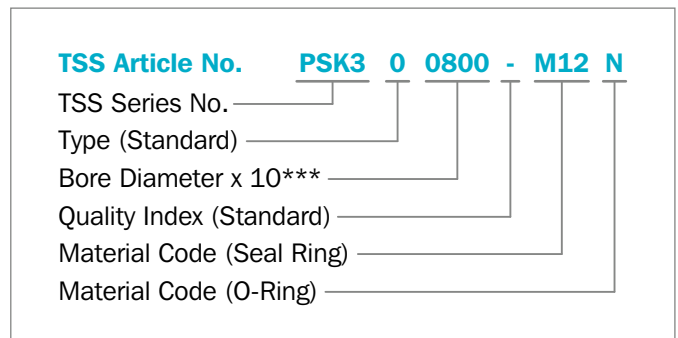

*** For diameters $D_N \geq 1,000.0$ mm multiply only by factor 1.
 Example: PSK6 for diameter $D_N = 1,200.0$ mm
 TSS Article No.: PSK6X1200 - M12N



Table 107: Installation Dimensions / TSS Part No.

Bore Dia.	Groove Dia.	Groove Width	TSS Part No.	O-Ring Dimensions	Bore Dia.	Groove Dia.	Groove Width	TSS Part No.	O-Ring Dimensions
D_N h9	d_1 h9	L_1 +0.2			D_N h9	d_1 h9	L_1 +0.2		
9.0	4.1	2.2	PSK000090	3.68 x 1.78	90.0	69.5	8.1	PSK400900	68.00 x 7.00
10.0	5.1	2.2	PSK000100	4.47 x 1.78	95.0	79.9	6.3	PSK300950	78.74 x 5.33
12.0	7.1	2.2	PSK000120	6.70 x 1.80	95.0	74.5	8.1	PSK400950	73.00 x 7.00
14.0	9.1	2.2	PSK000140	8.75 x 1.80	100.0	84.9	6.3	PSK301000	81.92 x 5.33
14.5	9.6	2.2	PSK000145	9.25 x 1.78	100.0	79.5	8.1	PSK401000	78.00 x 7.00
15.0	10.1	2.2	PSK000150	9.50 x 1.80	105.0	89.9	6.3	PSK301050	88.27 x 5.33
15.0	7.7	3.2	PSK100150	7.03 x 2.62	105.0	84.5	8.1	PSK401050	83.00 x 7.00
16.0	11.1	2.2	PSK000160	10.60 x 1.80	106.0	90.9	6.3	PSK301060	88.27 x 5.33
18.0	10.7	3.2	PSK100180	9.19 x 2.62	110.0	94.9	6.3	PSK301100	91.44 x 5.33
20.0	15.1	2.2	PSK000200	14.00 x 1.78	110.0	89.5	8.1	PSK401100	88.00 x 7.00
20.0	12.7	3.2	PSK100200	12.37 x 2.62	115.0	99.9	6.3	PSK301150	97.79 x 5.33
22.0	14.7	3.2	PSK100220	13.94 x 2.62	115.0	94.5	8.1	PSK401150	93.00 x 7.00
25.0	17.7	3.2	PSK100250	17.12 x 2.62	120.0	104.9	6.3	PSK301200	104.14 x 5.33
25.0	14.3	4.2	PSK200250	13.87 x 3.53	120.0	99.5	8.1	PSK401200	98.00 x 7.00
28.0	17.3	4.2	PSK200280	15.47 x 3.53	125.0	109.9	6.3	PSK301250	107.32 x 5.33
30.0	22.7	3.2	PSK100300	21.89 x 2.62	125.0	104.5	8.1	PSK401250	103.00 x 7.00
30.0	19.3	4.2	PSK200300	18.66 x 3.53	130.0	114.9	6.3	PSK301300	113.67 x 5.33
32.0	24.7	3.2	PSK100320	23.47 x 2.62	130.0	109.5	8.1	PSK401300	108.00 x 7.00
32.0	21.3	4.2	PSK200320	20.22 x 3.53	135.0	114.5	8.1	PSK401350	113.67 x 7.00
35.0	24.3	4.2	PSK200350	23.40 x 3.53	140.0	119.5	8.1	PSK401400	116.84 x 7.00
40.0	32.7	3.2	PSK100400	31.42 x 2.62	145.0	124.5	8.1	PSK401450	123.19 x 7.00
40.0	29.3	4.2	PSK200400	28.17 x 3.53	150.0	129.5	8.1	PSK401500	126.37 x 7.00
42.0	31.3	4.2	PSK200420	29.75 x 3.53	155.0	139.9	6.3	PSK301550	135.89 x 5.33
45.0	34.3	4.2	PSK200450	32.92 x 3.53	160.0	144.9	6.3	PSK301600	142.24 x 5.33
48.0	37.3	4.2	PSK200480	36.09 x 3.53	160.0	139.5	8.1	PSK401600	135.89 x 7.00
50.0	39.3	4.2	PSK200500	37.69 x 3.53	165.0	149.9	6.3	PSK301650	148.49 x 5.33
50.0	34.9	6.3	PSK300500	32.69 x 5.33	165.0	144.5	8.1	PSK401650	142.24 x 7.00
52.0	41.3	4.2	PSK200520	40.87 x 3.53	170.0	149.5	8.1	PSK401700	145.42 x 7.00
55.0	44.3	4.2	PSK200550	44.04 x 3.53	175.0	159.9	6.3	PSK301750	158.12 x 5.33
60.0	44.9	6.3	PSK300600	43.82 x 5.33	180.0	164.9	6.3	PSK301800	164.47 x 5.33
63.0	52.3	4.2	PSK200630	50.39 x 3.53	180.0	159.5	8.1	PSK401800	158.12 x 7.00
63.0	47.9	6.3	PSK300630	46.99 x 5.33	190.0	174.9	6.3	PSK301900	170.82 x 5.33
65.0	49.9	6.3	PSK300650	46.99 x 5.33	190.0	169.5	8.1	PSK401900	164.47 x 7.00
70.0	59.3	4.2	PSK200700	56.74 x 3.53	200.0	184.9	6.3	PSK302000	183.52 x 5.33
70.0	54.9	6.3	PSK300700	53.34 x 5.33	200.0	179.5	8.1	PSK402000	177.17 x 7.00
75.0	59.9	6.3	PSK300750	56.52 x 5.33	205.0	184.5	8.1	PSK402050	183.52 x 7.00
80.0	64.9	6.3	PSK300800	62.87 x 5.33	210.0	189.5	8.1	PSK402100	183.52 x 7.00
80.0	59.5	8.1	PSK400800	58.00 x 7.00	220.0	204.9	6.3	PSK302200	202.57 x 5.33
85.0	69.9	6.3	PSK300850	69.22 x 5.33	220.0	199.5	8.1	PSK402200	196.22 x 7.00
85.0	64.5	8.1	PSK400850	63.00 x 7.00	230.0	209.5	8.1	PSK402300	208.90 x 7.00
90.0	74.9	6.3	PSK300900	72.39 x 5.33	240.0	219.5	8.1	PSK402400	215.27 x 7.00



Bore Dia.	Groove Dia.	Groove Width	TSS Part No.	O-Ring Dimensions
D_N h9	d_1 h9	L_1 +0.2		
250.0	229.5	8.1	PSK402500	227.97 x 7.00
250.0	226.0	8.1	PSK802500	227.97 x 7.00
260.0	236.0	8.1	PSK802600	227.97 x 7.00
270.0	246.0	8.1	PSK802700	240.67 x 7.00
280.0	256.0	8.1	PSK802800	253.37 x 7.00
300.0	276.0	8.1	PSK803000	266.07 x 7.00
306.0	285.5	8.1	PSK403060	278.77 x 7.00
310.0	286.0	8.1	PSK803100	278.77 x 7.00
320.0	299.5	8.1	PSK403200	291.47 x 7.00
320.0	296.0	8.1	PSK803200	291.47 x 7.00
330.0	306.0	8.1	PSK803300	304.17 x 7.00
340.0	316.0	8.1	PSK803400	316.87 x 7.00
345.0	324.5	8.1	PSK403450	316.87 x 7.00
350.0	326.0	8.1	PSK803500	316.87 x 7.00
360.0	336.0	8.1	PSK803600	329.57 x 7.00
370.0	346.0	8.1	PSK803700	342.27 x 7.00
380.0	356.0	8.1	PSK803800	354.97 x 7.00
400.0	376.0	8.1	PSK804000	367.67 x 7.00
420.0	396.0	8.1	PSK804200	393.07 x 7.00
430.0	406.0	8.1	PSK804300	405.26 x 7.00
440.0	416.0	8.1	PSK804400	405.26 x 7.00
450.0	426.0	8.1	PSK804500	417.96 x 7.00

Bore Dia.	Groove Dia.	Groove Width	TSS Part No.	O-Ring Dimensions
D_N h9	d_1 h9	L_1 +0.2		
480.0	456.0	8.1	PSK804800	456.06 x 7.00
500.0	476.0	8.1	PSK805000	468.76 x 7.00
520.0	499.5	8.1	PSK405200	494.16 x 7.00
540.0	516.0	8.1	PSK805400	506.86 x 7.00
600.0	576.0	8.1	PSK806000	557.66 x 7.00
650.0	626.0	8.1	PSK806500	608.08 x 7.00
700.0	672.7	9.5	PSK507000	670.00 x 8.40
800.0	772.7	9.5	PSK508000	770.00 x 8.40
860.0	832.7	9.5	PSK508600	830.00 x 8.40
900.0	872.7	9.5	PSK509000	870.00 x 8.40
920.0	892.7	9.5	PSK509200	890.00 x 8.40
1,000.0	972.7	9.5	PSK5X1000	970.00 x 8.40
1,000.0	962.0	13.8	PSK6X1000	960.00 x 12.00
1,200.0	1,172.7	9.5	PSK5X1200	1,170.00 x 8.40
1,200.0	1,162.0	13.8	PSK6X1200	1,160.00 x 12.00
1,500.0	1,462.0	13.8	PSK6X1500	1,460.00 x 12.00
2,000.0	1,962.0	13.8	PSK6X2000	1,960.00 x 12.00
2,700.0	2,662.0	13.8	PSK6X2700	2,660.00 x 12.00

The bore diameters in **bold** type comply with the recommendations of ISO 3320. Other dimensions and all intermediate sizes up to 2,700 mm diameter including imperial (inch) sizes can be supplied.

All O-Rings with 12 mm cross section are delivered as special profile ring.

Turcon® Stepseal® V



Single-acting

Rubber-energized plastic-faced seal

Material:

Turcon®, Zurcon® and Elastomer



! This page is intentionally left blank.



■ Turcon® Stepseal® V*



■ Introduction

First invented by Trelleborg Sealing Solutions, a build-in check valve function eliminates pressure trap between seals in tandem sealing systems.

Stepseal® V has the efficient seal performance of the Turcon® Stepseal® range and the reliable prevention of pressure build-up brought by a refined check valve function. In dynamic applications Stepseal® V brings efficient, reliable sealing performance under even the most demanding service conditions.

Stepseal® V offers a uniform, low friction characteristic of the sealing system throughout its whole life, by preventing undefined pressurization of the secondary seal element.

CHARACTERISTICS

- Primary seal with hydrostatic ventilation
- Check valve function
- Hydrodynamic back-pumping
- Stabilised position in the groove
- Prolonged seal life
- Increased leakage control
- Only usable with a secondary seal

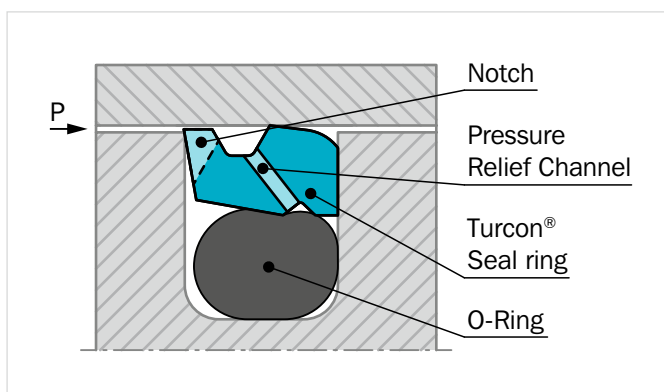

Figure 125: Turcon® Stepseal® V with tight axial groove fit

DESCRIPTION

Stepseal® V is a new generation primary seal designed for use in seal systems based on the dynamic, unidirectional Stepseal® sealing concept. Applied as a piston seal, Stepseal® V is preferably used with a double-acting seal from the Turcon® range of piston seals. Under extreme performance requirements Stepseal® V offers improved leakage control, extended service life and increased reliability.

The sealing performance of the patented Stepseal® V design – Figure 125 – results from a combination of the hydrodynamic properties of the seal and the O-Ring and the hydrostatic pressure relief check valve function.

The classic Stepseal® operation ensures a controlled pressure gradient that minimizes fluid adherence to the cylinder bore during the stroke, and enables residual fluid film on the bore to be returned under the seal on the return stroke.

The O-Ring check valve function controls the operation of the pressure relief channel: When the seal is pressurized by the system pressure the O-Ring keeps the channel closed to ensure that the hydraulic fluid is not passing through the channel and further between the groove wall and the Turcon® Seal Ring.

If the pressure is higher than the actual system pressure, appears between Stepseal® V and the secondary seal, the O-Ring opens the relief groove and the inter-seal pressure is immediately relieved.

Stepseal® V is available in high-grade Turcon® or Zurcon® materials with outstanding sliding and wear resistance properties.

* Patent application: WO 2007/131468 A1



ADVANTAGES:

- No pressure build-up on secondary sealing element and Excluder®
- Check valve function of O-Ring eliminates risk of fluid bypassing the seal during pressure loading when pressurised
- Independent of any speed relation of counter surface
- Independent of stroke length
- High tolerance to hardware non-concentricity and radial play
- Minimum contribution of friction of secondary sealing element
- Minimum wear of secondary sealing element
- Increased leakage control
- Prolonged seal life
- Increased operational reliability
- Fits standard Turcon® Stepseal® 2K groove dimensions as well as ISO 7425-1 seal housings

APPLICATION EXAMPLES

- Piston accumulators
- Single acting hydraulic cylinders
- Pistons with tandem sealing system
- Mobile crane boom cylinders
- Hydro plant cylinders
- Storm barrier cylinders
- Long stroke cylinders
- Gas spring suspension
- Piling Barges
- Theater hydraulics
- Safety systems

OPERATING CONDITIONS

Pressure:	Up to 50 MPa (Turcon® M12) Up to 60 MPa (Turcon® T08 and Zurcon® Z53)
Speed:	Up to 15 m/s with linear movements, frequency up to 15 Hz
Temperature:	-45 °C to +200 °C* depending on seal and O-Ring material

Media:	Mineral oil based hydraulic fluids, flame retardant hydraulic fluids, environmentally friendly hydraulic fluids (bio-oils), phosphate ester, water and others, depending on the seal and O-Ring material compatibility - see Table 109.
Clearance:	The maximum permissible radial clearance S_{max} is shown in Table 110, as a function of the operating pressure and functional diameter.

IMPORTANT NOTE

The above data are maximum values and cannot be used at the same time, e.g. the maximum operating speed depends on material type, pressure, temperature and gap value. Temperature range also depends on media.

* In the case of unpressurized applications in temperatures below 0 °C please contact your local Customer Solution Center for more information!

SERIES

Different cross section sizes are recommended as a function of the seal diameters.

Table 108 shows the relationship between the series number according to the seal diameter range and the different application class sizes:

Standard application:	General applications without exceptional operating conditions.
Light application:	Applications with demands for reduced friction or for smaller grooves.
Heavy-duty application:	For exceptional operating loads such as high pressures, pressure peaks, etc.

**Table 108: Available Range**

Series No.	Piston Diameter D _N H9
PSV20	15.0 - 200.0
PSV30	27.0 - 256.0
PSV40	60.0 - 700.0
PSV80	133.0 - 999.9
PSV50	250.0 - 999.9
PSV5X	1,000.0 - 1,200.0
PSV60	670.0 - 999.9
PSV6X	1,000.0 - 2,700.0

For the recommended Standard Application range see Table 110

REDUNDANT SEALING SYSTEM

In many applications a secondary seal is needed e.g. for safety requirements. Figure 126 shows such a tandem configuration with Stepseal® V.

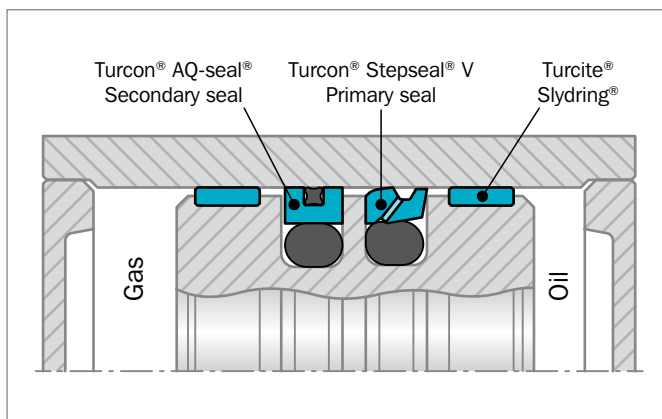

Figure 126: Tandem Turcon® Stepseal® V and Turcon® AQ-Seal® configuration in piston accumulator

When utilizing Stepseal® V, with valve function, there will be no pressure trap between the primary and secondary seals and no extra space between them is required to accumulate hydraulic fluid.

INSTALLATION INSTRUCTIONS

Stepseal® V is installed according to information on page 247 to page 249.

Closed groove installation according to dimensions in Table 80 page 249.

RECOMMENDED MATERIALS

The following material combinations have proven effective for hydraulic applications:

Turcon® Stepseal® V in Turcon® M12

All round material for light to heavy hydraulic applications with linear, short stroke or helical movements in mineral oils, flame retardant hydraulic fluids, phosphate ester, bio-oils or fluids having low lubricating properties:

O-Ring: NBR 70 Shore A N
FKM 70 Shore A V

Set code: M12N or M12V

Turcon® Stepseal® V in Turcon® T46

For medium to heavy applications with linear movements in mineral oils and other media with good lubrication:

O-Ring: NBR 70 Shore A N
FKM 70 Shore A V

Set code: T46N or T46V

For specific applications, all Turcon® materials are available.

Other material combinations are listed in Table 109.



Table 109: Turcon® and Zurcon® Materials for Stepseal® V

Material, Applications, Properties	Code	O-Ring Material Shore A	Code	O-Ring Operating Temp. * °C	Mating Surface Material	MPa max. Dynamic
Turcon® M12 First material choice for seals in linear motion Overall improved properties For new constructions and updating For all commonly applied hydraulic fluids including fluids with low lubrication performance Lowest friction and best sliding properties Lowest wear on seals Improved absorption of abrasive contaminants Low wear or abrasion of counter surface BAM tested Mineral fiber and Additives filled Color: Dark gray	M12	NBR 70	N	-30 to +100	Steel	50
		NBR 70 Low temp.	T	-45 to +80	Steel hardened Cast iron	
		FKM 70	V	-10 to +200	Stainless steel Titanium	
Turcon® T05 For lubricating fluids Also for gas service Very low friction Very good sliding and sealing properties Color: Turquoise	T05	NBR 70	N	-30 to +100	Steel	20
		NBR 70 Low temp.	T	-45 to +80	Steel hardened	
		FKM 70	V	-10 to +200		
Turcon® T08 For lubricating fluids and linear motion Very high compressive strength and extrusion resistance Hard counter surfaces is recommended Bronze filled Color: Light to dark brown, which may have variations in shading	T08	NBR 70	N	-30 to +100	Steel hardened	60
		NBR 70 Low temp.	T	-45 to +80	Cast iron	
		FKM 70	V	-10 to +200		
Turcon® T10 For hydraulic and pneumatic For linear motion in lubricating and non-lubricating fluids High extrusion resistance Good chemical resistance Not for electrically conducting fluids BAM tested Carbon, graphite filled Color: Black	T10	NBR 70	N	-30 to +100	Steel	40
		NBR 70 Low temp.	T	-45 to +80	Steel hardened Stainless steel	
		FKM 70	V	-10 to +200		
		EPDM 70	E**	-45 to +145		
Turcon® T29 For lubricating and non-lubricating fluids Good extrusion resistance Surface texture is not suitable for gas sealing Not for electrically conducting fluids Carbon fiber filled Color: Gray	T29	NBR 70	N	-30 to +100	Steel	30
		NBR 70 Low temp.	T	-45 to +80	Steel hardened Cast iron	
		FKM 70	V	-10 to +200	Stainless steel	
		EPDM 70	E**	-45 to +145		



Material, Applications, Properties	Code	O-Ring Material Shore A	Code	O-Ring Operating Temp. * °C	Mating Surface Material	MPa max. Dynamic
Turcon® T40 For lubricating and non-lubricating fluids High frequency and short strokes Water hydraulics Surface texture is not suitable for gas sealing Carbon fiber filled Color: Gray	T40	NBR 70	N	-30 to +100	Steel	25
		NBR 70 Low temp.	T	-45 to +80	Steel hardened Cast iron	
		FKM 70	V	-10 to +200	Stainless steel Aluminum	
		EPDM 70	E**	-45 to +145		
Turcon® T46 For lubricated hydraulics in linear motion High compressive strength High extrusion resistance Very good sliding and wear properties BAM tested Bronze filled Color: Light to dark brown, which may have variations in shading	T46	NBR 70	N	-30 to +100	Steel hardened	50
		NBR 70 Low temp.	T	-45 to +80	Cast iron	
		FKM 70	V	-10 to +200		
Zurcon® Z53*** For mineral oil based fluids Very high abrasion and extrusion resistance For counter surface with rougher surface finish Limited chemical resistance Max. working temperature 110 °C Cast polyurethane Color: Yellow to light-brown	Z53	NBR 70	N	-30 to +100	Steel	60
		NBR 70 Low temp.	T	-45 to +80	Steel hardened Steel chrome plated (rod) Cast iron Stainless steel Ceramic coating	
Zurcon® Z80 For lubricating and non-lubricating fluids Water based fluids, air and gases Dry air pneumatics High abrasion and extrusion resistance For service in abrasive conditions and media with particles Good chemical resistance Limited temperature capability (-60 to +80 °C) UHMWPE (Ultra High Molecular Weight Polyethylene) Color: White to off-white	Z80	NBR 70	N	-30 to (+100)	Steel	35
		NBR 70 Low temp.	T	-45 to +80	Steel hardened Stainless steel Aluminum	
		EPDM 70	E**	-45 to (+145)	Ceramic coating	

* The O-Ring Operation Temperature is only valid in mineral hydraulic oil (except EPDM).

** Material not suitable for mineral oils.

** Max. diameter 2,300 mm

BAM: Tested by "Bundesanstalt Materialprüfung, Germany".

 Highlighted materials are recommended.



■ Installation Recommendation

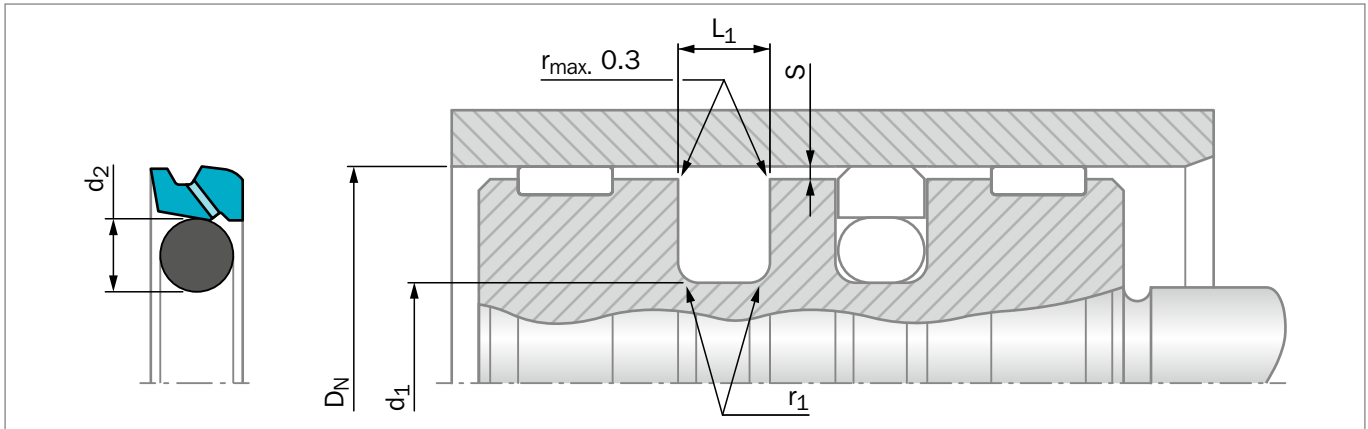

Figure 127: Installation Drawing

Table 110: Installation Dimensions – Standard Recommendations

Series No.	Bore Diameter D_N H9			Groove Diameter d_1 h9	Groove Width $L_1 + 0.2$	Radius r_1 max	Radial Clearance S_{max}^*			O-Ring Cross Section d_2
	Standard Application	Light Application	Heavy Duty Application				10 MPa	20 MPa	40 MPa	
PSV2	25 - 59.9	60 - 199.9	15 - 24.9	$D_N - 10.7$	4.2	1.0	0.50	0.30	0.20	3.53
PSV3	60 - 199.9	200 - 255.9	25 - 59.9	$D_N - 15.1$	6.3	1.3	0.70	0.40	0.25	5.33
PSV4	200 - 255.9	256 - 669.9	60 - 199.9	$D_N - 20.5$	8.1	1.8	0.80	0.60	0.35	7.00
PSV8	256 - 669.9	670 - 999.9	200 - 255.9	$D_N - 24.0$	8.1	1.8	0.90	0.70	0.40	7.00
PSV5	670 - 999.9	-	256 - 669.9	$D_N - 27.3$	9.5	2.5	1.00	0.80	0.50	8.40
PSV5X	-	1,000 - 1,200	-	$D_N - 27.3$	9.5	2.5	1.00	0.80	0.50	8.40
PSV6**	-	-	670 - 999.9	$D_N - 38.0$	13.8	3.0	1.20	0.90	0.60	12.00
PSV6X**	1,000 - 2,700	-	-	$D_N - 38.0$	13.8	3.0	1.20	0.90	0.60	12.00

* At pressures > 40 MPa use diameter tolerance H8/f8 (bore/piston) in the area behind seal or consult your local Customer Solution Center for alternative material or profiles.

Slydring® / Wear Rings are not applicable at very small radial clearances please consult the Slydring® section in this catalog.

** All O-Rings with 12 mm cross section are delivered as special profile ring.

ORDERING EXAMPLE

Turcon® Stepseal® V complete with O-Ring, standard application:

Series:	PSV3 from Table 110
Bore Diameter:	$D_N = 80.0$ mm
TSS Part No.:	PSV300800 from Table 111

Select the material from Table 109. The corresponding code numbers are appended to the TSS Part No. Together these form the TSS Article Number. The TSS Article Number for all intermediate sizes can be determined by following the example:

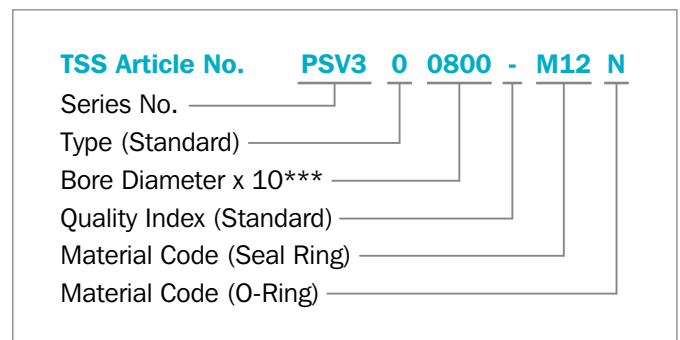

*** For diameters $D_N \geq 1,000.0$ mm multiply only by factor 1.

Example: PSVK6 for diameter $D_N = 1,200.0$ mm
TSS Article No.: PSV6X1200 - M12N



Table 111: Installation Dimensions / TSS Part No.

Bore Dia.	Groove Dia.	Groove Width	TSS Part No.	O-Ring Dimensions	Bore Dia.	Groove Dia.	Groove Width	TSS Part No.	O-Ring Dimensions
D _N H9	d ₁ h9	L ₁ +0.2			D _N H9	d ₁ h9	L ₁ +0.2		
15.0	4.3	4.2	PSV200150	3.47 x 3.53	115.0	99.9	6.3	PSV301150	97.79 x 5.33
20.0	9.3	4.2	PSV200200	8.47 x 3.53	115.0	94.5	8.1	PSV401150	93.00 x 7.00
25.0	14.3	4.2	PSV200250	13.87 x 3.53	120.0	104.9	6.3	PSV301200	104.14 x 5.33
28.0	17.3	4.2	PSV200280	15.47 x 3.53	120.0	99.5	8.1	PSV401200	98.00 x 7.00
30.0	19.3	4.2	PSV200300	18.66 x 3.53	125.0	109.9	6.3	PSV301250	107.32 x 5.33
32.0	21.3	4.2	PSV200320	20.22 x 3.53	125.0	104.5	8.1	PSV401250	103.00 x 7.00
35.0	24.3	4.2	PSV200350	23.40 x 3.53	130.0	114.9	6.3	PSV301300	113.67 x 5.33
40.0	29.3	4.2	PSV200400	28.17 x 3.53	130.0	109.5	8.1	PSV401300	108.00 x 7.00
42.0	31.3	4.2	PSV200420	29.75 x 3.53	135.0	114.5	8.1	PSV401350	113.67 x 7.00
45.0	34.3	4.2	PSV200450	32.92 x 3.53	140.0	119.5	8.1	PSV401400	116.84 x 7.00
48.0	37.3	4.2	PSV200480	36.09 x 3.53	145.0	124.5	8.1	PSV401450	123.19 x 7.00
50.0	39.3	4.2	PSV200500	37.69 x 3.53	150.0	129.5	8.1	PSV401500	126.37 x 7.00
50.0	34.9	6.3	PSV300500	32.69 x 5.33	155.0	139.9	6.3	PSV301550	135.89 x 5.33
52.0	41.3	4.2	PSV200520	40.87 x 3.53	160.0	144.9	6.3	PSV301600	142.24 x 5.33
55.0	44.3	4.2	PSV200550	44.04 x 3.53	160.0	139.5	8.1	PSV401600	135.89 x 7.00
55.0	39.9	6.3	PSV300550	37.47 x 5.33	165.0	149.9	6.3	PSV301650	148.49 x 5.33
60.0	44.9	6.3	PSV300600	43.82 x 5.33	165.0	144.5	8.1	PSV401650	142.24 x 7.00
62.0	51.3	4.2	PSV200620	50.39 x 3.53	170.0	149.5	8.1	PSV401700	145.42 x 7.00
63.0	52.3	4.2	PSV200630	50.39 x 3.53	175.0	159.9	6.3	PSV301750	158.12 x 5.33
63.0	47.9	6.3	PSV300630	46.99 x 5.33	180.0	164.9	6.3	PSV301800	164.47 x 5.33
65.0	49.9	6.3	PSV300650	46.99 x 5.33	180.0	159.5	8.1	PSV401800	158.12 x 7.00
70.0	59.3	4.2	PSV200700	56.74 x 3.53	190.0	174.9	6.3	PSV301900	170.82 x 5.33
70.0	54.9	6.3	PSV300700	53.34 x 5.33	190.0	169.5	8.1	PSV401900	164.47 x 7.00
70.0	49.5	8.1	PSV400700	48.00 x 7.00	195.0	174.5	8.1	PSV401950	170.82 x 7.00
75.0	59.9	6.3	PSV300750	56.52 x 5.33	200.0	184.9	6.3	PSV302000	183.52 x 5.33
80.0	64.9	6.3	PSV300800	62.87 x 5.33	200.0	179.5	8.1	PSV402000	177.17 x 7.00
80.0	59.5	8.1	PSV400800	58.00 x 7.00	205.0	184.5	8.1	PSV402050	183.52 x 7.00
85.0	69.9	6.3	PSV300850	69.22 x 5.33	210.0	189.5	8.1	PSV402100	183.52 x 7.00
85.0	64.5	8.1	PSV400850	63.00 x 7.00	220.0	204.9	6.3	PSV302200	202.57 x 5.33
90.0	74.9	6.3	PSV300900	72.39 x 5.33	220.0	199.5	8.1	PSV402200	196.22 x 7.00
90.0	69.5	8.1	PSV400900	68.00 x 7.00	230.0	209.5	8.1	PSV402300	208.90 x 7.00
95.0	79.9	6.3	PSV300950	78.74 x 5.33	240.0	219.5	8.1	PSV402400	215.27 x 7.00
95.0	74.5	8.1	PSV400950	73.00 x 7.00	250.0	229.5	8.1	PSV402500	227.97 x 7.00
100.0	84.9	6.3	PSV301000	81.92 x 5.33	250.0	226.0	8.1	PSV802500	227.97 x 7.00
100.0	79.5	8.1	PSV401000	78.00 x 7.00	260.0	236.0	8.1	PSV802600	227.97 x 7.00
105.0	89.9	6.3	PSV301050	88.27 x 5.33	270.0	246.0	8.1	PSV802700	240.67 x 7.00
105.0	84.5	8.1	PSV401050	83.00 x 7.00	280.0	256.0	8.1	PSV802800	253.37 x 7.00
106.0	90.9	6.3	PSV301060	88.27 x 5.33	300.0	276.0	8.1	PSV803000	266.07 x 7.00
110.0	94.9	6.3	PSV301100	91.44 x 5.33	306.0	285.5	8.1	PSV403060	278.77 x 7.00
110.0	89.5	8.1	PSV401100	88.00 x 7.00	310.0	286.0	8.1	PSV803100	278.77 x 7.00



Bore Dia.	Groove Dia.	Groove Width	TSS Part No.	O-Ring Dimensions
D_N H9	d_1 h9	L_1 +0.2		
320.0	299.5	8.1	PSV403200	291.47 x 7.00
320.0	296.0	8.1	PSV803200	291.47 x 7.00
330.0	306.0	8.1	PSV803300	304.17 x 7.00
340.0	316.0	8.1	PSV803400	316.87 x 7.00
345.0	324.5	8.1	PSV403450	316.87 x 7.00
350.0	326.0	8.1	PSV803500	316.87 x 7.00
360.0	336.0	8.1	PSV803600	329.57 x 7.00
370.0	346.0	8.1	PSV803700	342.27 x 7.00
380.0	356.0	8.1	PSV803800	354.97 x 7.00
400.0	376.0	8.1	PSV804000	367.67 x 7.00
420.0	396.0	8.1	PSV804200	393.07 x 7.00
430.0	406.0	8.1	PSV804300	405.26 x 7.00
440.0	416.0	8.1	PSV804400	405.26 x 7.00
450.0	426.0	8.1	PSV804500	417.96 x 7.00
480.0	456.0	8.1	PSV804800	456.06 x 7.00
500.0	476.0	8.1	PSV805000	468.76 x 7.00
520.0	499.5	8.1	PSV405200	494.16 x 7.00
540.0	516.0	8.1	PSV805400	506.86 x 7.00
600.0	576.0	8.1	PSV806000	557.66 x 7.00
650.0	626.0	8.1	PSV806500	608.08 x 7.00

Bore Dia.	Groove Dia.	Groove Width	TSS Part No.	O-Ring Dimensions
D_N H9	d_1 h9	L_1 +0.2		
700.0	672.7	9.5	PSV507000	670.00 x 8.40
780.0	752.7	9.5	PSV507800	750.00 x 8.40
800.0	772.7	9.5	PSV508000	770.00 x 8.40
820.0	792.7	9.5	PSV508200	790.00 x 8.40
860.0	832.7	9.5	PSV508600	830.00 x 8.40
900.0	872.7	9.5	PSV509000	870.00 x 8.40
920.0	892.7	9.5	PSV509200	890.00 x 8.40
1,000.0	972.7	9.5	PSV5X1000	970.00 x 8.40
1,000.0	962.0	13.8	PSV6X1000	960.00 x 12.00
1,200.0	1,172.7	9.5	PSV5X1200	1,171.00 x 8.40
1,200.0	1,162.0	13.8	PSV6X1200	1,160.00 x 12.00
1,500.0	1,462.0	13.8	PSV6X1500	1,460.00 x 12.00
2,000.0	1,962.0	13.8	PSV6X2000	1,960.00 x 12.00
2,650.0	2,612.0	13.8	PSV6X2650	2,610.00 x 12.00
2,700.0	2,662.0	13.8	PSV6X2700	2,660.00 x 12.00

The bore diameters in **bold** type comply with the recommendations of ISO 3320.

Other dimensions and all intermediate sizes up to 2,700 mm diameter including imperial (inch) sizes can be supplied.

All O-Rings with 12 mm cross section are delivered as special profile ring.

Turcon® Stepseal® V LM



Single-acting

Designed for Lubrication Management
Technology

Rubber-energized plastic-faced seal

Material:

Turcon®, Zurcon® and Elastomer



! This page is intentionally left blank.



■ Turcon® Stepseal® V LM



■ Description

Turcon® Stepseal® V LM is a new type of primary seal, conceived and developed to improve system performance and service life of the whole system, including hardware and other seals.

Stepseal® V LM is the first unidirectional seal element to integrate the Lubrication Management principles developed by Trelleborg Sealing Solutions as a standard feature.

Traditionally, unidirectional seals provide sealing by means of sharp, defined sealing edges, which establish high contact pressure with the hardware and suppress fluid film during the forward stroke.

With Lubrication Management, a modified seal edge reduces contact pressure with the hardware and supports the formation of a lubricating fluid film during the forward stroke. This allows fluid to reach secondary seals and scrapers in a controlled way, while back-pumping of fluid ensures lubrication during the return stroke. The efficient, built-in check valve action introduced with Stepseal® V protects secondary seals and scrapers against system pressure and ensures that pressure build-up between the seals is eliminated.

Lower contact pressure and improved lubrication reduce the mechanical and thermal load on seals and on the hardware, resulting in increased service life and system reliability.

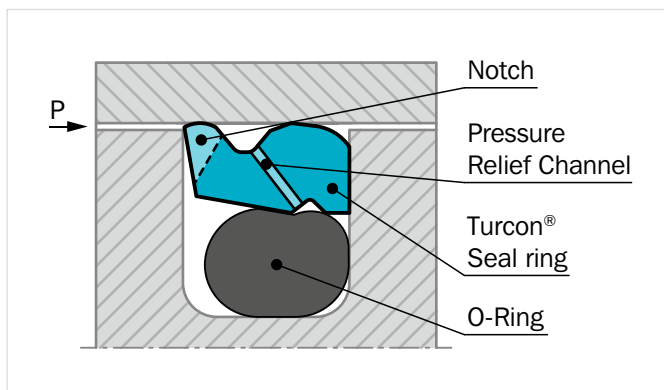

Figure 128: Turcon® Stepseal® V LM

ADVANTAGES:

- Built-in check valve performance identical to that of Stepseal® V
- No pressure build-up on secondary sealing element and Excluder®
- Independent of in- and out-stroke velocity
- High tolerance to hardware non-concentricity and radial play
- Minimum contribution to friction by secondary sealing element and Excluder®
- Minimum wear of secondary sealing element and Excluder®
- Robust, optimized seal face
- Increased leakage control
- Extended seal life
- Increased operational reliability
- Fits standard Stepseal® 2K groove dimensions as well as ISO 7425 seal housings

APPLICATION EXAMPLES

- Wind turbine pitch control
- Production presses
- Injection molding clamping cylinders
- Mobile cranes and lifts
- Vehicle suspensions



CHARACTERISTICS

- Primary seal with hydrostatic pressure release
- Check valve function
- Hydrodynamic back-pumping
- Stabilized position in the groove
- Extended seal life
- Improved system reliability

IMPROVED FRICTION PERFORMANCE

Turcon® Stepseal® V LM offers uniform low friction for the complete sealing system through improved lubrication of all sealing elements and by preventing pressurization of the secondary seal element.

FEATURES

Stepseal® V LM combines efficiency with reliability and longevity for the full sealing system and hardware. Controlled support of lubrication and lowered contact pressure reduce friction and wear, while the refined valve function eliminates pressure build-up in seal systems, making drain lines and buffer volumes between the seals a thing of the past.

OPERATING CONDITIONS

Pressure:	Up to 50 MPa (Turcon® M12) Up to 60 MPa (Turcon® T08 and Zurcon® Z53)
Speed:	Up to 15 m/s with linear movements, frequency up to 15 Hz
Temperature:	-45 °C to +200 °C* depending on seal and O-Ring material
Media:	Mineral oil based hydraulic fluids, flame retardant hydraulic fluids, environmentally friendly fluids (bio-oils), phosphate ester, water and others, depending on the seal and O-Ring material. See Table 113.
Clearance:	The maximum permissible radial clearance S_{max} is shown in Table 114, as a function of the operating pressure and functional diameter.

IMPORTANT NOTE

The above data are maximum values and cannot be used at the same time, e.g. the maximum operating speed depends on material type, pressure, temperature and gap value. Temperature range also depends on media.

* In the case of unpressurized applications in temperatures below 0 °C please contact your local Customer Solution Center for more information.

SERIES

Different cross section sizes are recommended as a function of the seal diameters.

Table 112 shows the relationship between the series number according to the seal diameter range and the different application class sizes:

Standard application:	General applications without exceptional operating conditions.
Light application:	Applications with demands for reduced friction or for smaller grooves.
Heavy-duty application:	For exceptional operating loads such as high pressures, pressure peaks, large clearances, etc.

**Table 112: Available Range**

Series No.	Rod Diameter d_N f8/h9
PSL20	15.0 - 200.0
PSL30	27.0 – 256.0
PSL40	60.0 – 670.0
PSL80	133.0 - 999.9
PSL50	250.0 - 999.9
PSL5X	1,000.0 - 1,200.0
PSL60	670.0 - 999.9
PSL6X	1,000.0 - 2,700.0

SEALING SYSTEM

Stepseal® V LM is developed for use with a secondary sealing element. Figure 129 shows such a tandem configuration with Stepseal® V LM.

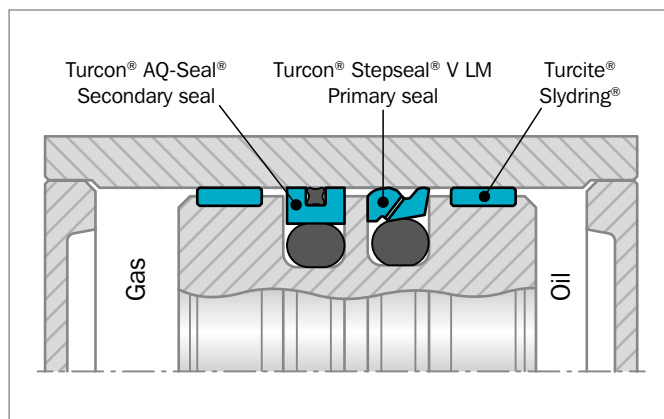

Figure 129: Turcon® Stepseal® V LM and Turcon® AQ-Seal® in tandem configuration

The integrated check valve function of Stepseal® V LM ensures that pressure cannot be trapped between the primary and secondary seals, and no extra space between them is required to accumulate hydraulic fluid.

Depending on the application and the operating conditions, the combination of different materials offers a further improvement in the sealing efficiency and the service life of the system. For example in hydraulic cylinders subject to high loads and under rough operating conditions, the primary seal should be made of Turcon® and the secondary seal of Zurcon®.

INSTALLATION INSTRUCTIONS

Stepseal® V LM is installed according to information on page 247 to page 249.

Closed groove installation according to dimensions in Table 80 page 249.

RECOMMENDED MATERIALS

The following material combinations have proven effective for hydraulic applications:

Turcon® Stepseal® V LM in Turcon® M12

All round material for light to heavy hydraulic applications with linear, short stroke or helical movements in mineral oils, flame retardant hydraulic fluids, phosphate ester, bio-oils or fluids having low lubricating properties:

O-Ring: NBR 70 Shore A N
FKM 70 Shore A V

Set code: M12N or M12V

Turcon® Stepseal® V LM in Turcon® T46

For medium to heavy applications with linear movements in mineral oils and other media with good lubrication:

O-Ring: NBR 70 Shore A N
FKM 70 Shore A V

Set code: T46N or T46V

For specific applications, all Turcon® materials are available.

Other material combinations are listed in Table 113.



Table 113: Turcon® and Zurcon® Materials for Stepseal® V LM

Material, Applications, Properties	Code	O-Ring Material Shore A	Code	O-Ring Operating Temp. * °C	Mating Surface Material	MPa max. Dynamic
Turcon® M12 First material choice for seals in linear motion Overall improved properties For new constructions and updating For all commonly applied hydraulic fluids including fluids with low lubrication performance Lowest friction and best sliding properties Lowest wear on seals Improved absorption of abrasive contaminants Low wear or abrasion of counter surface BAM tested Mineral fiber and Additives filled Color: Dark gray	M12	NBR 70	N	-30 to +100	Steel	50
		NBR 70 Low temp.	T	-45 to +80	Steel hardened Cast iron	
		FKM 70	V	-10 to +200	Stainless steel Titanium	
Turcon® T05 For lubricating fluids Also for gas service Very low friction Very good sliding and sealing properties Color: Turquoise	T05	NBR 70	N	-30 to +100	Steel	20
		NBR 70 Low temp.	T	-45 to +80	Steel hardened	
		FKM 70	V	-10 to +200		
Turcon® T08 For lubricating fluids and linear motion Very high compressive strength and extrusion resistance Hard counter surfaces is recommended Bronze filled Color: Light to dark brown, which may have variations in shading	T08	NBR 70	N	-30 to +100	Steel hardened	60
		NBR 70 Low temp.	T	-45 to +80	Cast iron	
		FKM 70	V	-10 to +200		
Turcon® T10 For hydraulic and pneumatic For linear motion in lubricating and non-lubricating fluids High extrusion resistance Good chemical resistance Not for electrically conducting fluids BAM tested Carbon, graphite filled Color: Black	T10	NBR 70	N	-30 to +100	Steel	40
		NBR 70 Low temp.	T	-45 to +80	Steel hardened Stainless steel	
		FKM 70	V	-10 to +200		
		EPDM 70	E**	-45 to +145		
Turcon® T29 For lubricating and non-lubricating fluids Good extrusion resistance Surface texture is not suitable for gas sealing Not for electrically conducting fluids Carbon fiber filled Color: Gray	T29	NBR 70	N	-30 to +100	Steel	30
		NBR 70 Low temp.	T	-45 to +80	Steel hardened Cast iron	
		FKM 70	V	-10 to +200	Stainless steel	
		EPDM 70	E**	-45 to +145		



Material, Applications, Properties	Code	O-Ring Material Shore A	Code	O-Ring Operating Temp. * °C	Mating Surface Material	MPa max. Dynamic
Turcon® T40 For lubricating and non-lubricating fluids High frequency and short strokes Water hydraulics Surface texture is not suitable for gas sealing Carbon fiber filled Color: Gray	T40	NBR 70	N	-30 to +100	Steel	25
		NBR 70 Low temp.	T	-45 to +80	Steel hardened Cast iron	
		FKM 70	V	-10 to +200	Stainless steel Aluminum	
		EPDM 70	E**	-45 to +145		
Turcon® T46 For lubricated hydraulics in linear motion High compressive strength High extrusion resistance Very good sliding and wear properties BAM tested Bronze filled Color: Light to dark brown, which may have variations in shading	T46	NBR 70	N	-30 to +100	Steel hardened	50
		NBR 70 Low temp.	T	-45 to +80	Cast iron	
		FKM 70	V	-10 to +200		
Zurcon® Z53*** For mineral oil based fluids Very high abrasion and extrusion resistance For counter surface with rougher surface finish Limited chemical resistance Max. working temperature 110 °C Cast polyurethane Color: Yellow to light-brown	Z53	NBR 70	N	-30 to +100	Steel	60
		NBR 70 Low temp.	T	-45 to +80	Steel hardened Steel chrome plated (rod) Cast iron Stainless steel Ceramic coating	
Zurcon® Z80 For lubricating and non-lubricating fluids Water based fluids, air and gases Dry air pneumatics High abrasion and extrusion resistance For service in abrasive conditions and media with particles Good chemical resistance Limited temperature capability (-60 to +80 °C) UHMWPE (Ultra High Molecular Weight Polyethylene) Color: White to off-white	Z80	NBR 70	N	-30 to (+100)	Steel	35
		NBR 70 Low temp.	T	-45 to +80	Steel hardened Stainless steel Aluminum	
		EPDM 70	E**	-45 to (+145)	Ceramic coating	

* The O-Ring Operation Temperature is only valid in mineral hydraulic oil (except EPDM).

** Material not suitable for mineral oils.

** Max. diameter 2,300 mm

BAM: Tested by "Bundesanstalt Materialprüfung, Germany".

 Highlighted materials are recommended.



Installation Recommendation

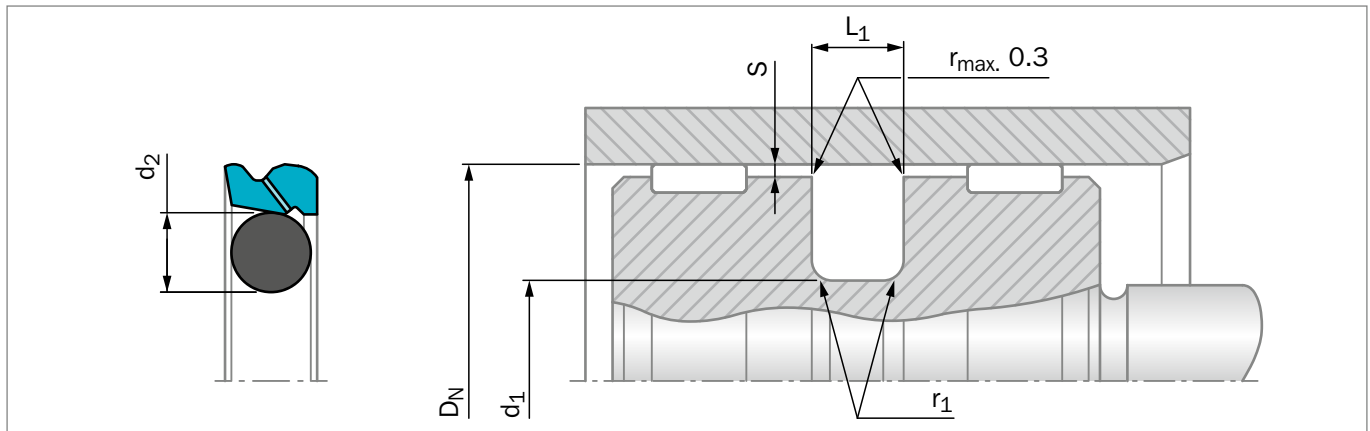

Figure 130: Installation Drawing

Table 114: Installation Dimensions – Standard Recommendations

Series No.	Rod Diameter D_N H9			Groove Diameter d_1 h9	Groove Width $L_1 + 0.2$	Radius r_1 max	Radial Clearance S_{max}^*			O-Ring Cross Section d_2
	Standard Application	Light Application	Heavy Duty Application				10 MPa	20 MPa	40 MPa	
PSL20	25 - 59.9	60 - 199.9	15 - 24.9	$D_N - 10.7$	4.2	1.0	0.50	0.30	0.20	3.53
PSL30	60 - 199.9	200 - 255.9	25 - 59.9	$D_N - 15.1$	6.3	1.3	0.70	0.40	0.25	5.33
PSL40	200 - 255.9	256 - 669.9	60 - 199.9	$D_N - 20.5$	8.1	1.8	0.80	0.60	0.35	7.00
PSL80	256 - 669.9	670 - 999.9	200 - 255.9	$D_N - 24.0$	8.1	1.8	0.90	0.70	0.40	7.00
PSL50	670 - 999.9	-	256 - 669.9	$D_N - 27.3$	9.5	2.5	1.00	0.80	0.50	8.40
PSL5X	-	1,000 - 1,200	-	$D_N - 27.3$	9.5	2.5	1.00	0.80	0.50	8.40
PSL60**	-	-	670 - 999.9	$D_N - 38.0$	13.8	3.0	1.20	0.90	0.60	12.00
PSL6X**	1,000 - 2,700	-	-	$D_N - 38.0$	13.8	3.0	1.20	0.90	0.60	12.00

* At pressures > 40 MPa use diameter tolerance H8/f8 (bore/rod) in the area behind seal or consult your local Customer Solution Center for alternative material or profiles.

Slydring® / Wear Rings are not applicable at very small radial clearances S, please consult the Slydring® section in this catalog.

** All O-Rings with 12 mm cross section are delivered as special profile ring.

ORDERING EXAMPLE

Turcon® Stepseal® V LM complete with O-Ring, standard application:

Series:	PSL3 from Table 114
Bore Diameter:	$D_N = 80.0$ mm
TSS Part No.:	PSL300800 from Table 115

Select the material from Table 113. The corresponding code numbers are appended to the TSS Part No. Together these form the TSS Article Number. The TSS Article Number for all intermediate sizes can be determined by following the example:

TSS Article No. **PSL3 0 0800 - M12 N**

Series No. _____

Type (Standard) _____

Bore Diameter x 10*** _____

Quality Index (Standard) _____

Material Code (Seal Ring) _____

Material Code (O-Ring) _____

*** For diameters $D_N \geq 1,000.0$ mm multiply only by factor 1.

Example: PSL6 for diameter $D_N = 1,200.0$ mm
TSS Article No.: PSL6X1200 - M12N



Table 115: Installation Dimensions / TSS Part No.

Bore Dia.	Groove Dia.	Groove Width	TSS Part No.	O-Ring Dimensions	Bore Dia.	Groove Dia.	Groove Width	TSS Part No.	O-Ring Dimensions
D _N H9	d ₁ h9	L ₁ +0.2			D _N H9	d ₁ h9	L ₁ +0.2		
15.0	4.3	4.2	PSL200150	3.47 x 3.53	115.0	99.9	6.3	PSL301150	97.79 x 5.33
20.0	9.3	4.2	PSL200200	8.47 x 3.53	115.0	94.5	8.1	PSL401150	93 x 7.00
25.0	14.3	4.2	PSL200250	13.87 x 3.53	120.0	104.9	6.3	PSL301200	104.14 x 5.33
28.0	17.3	4.2	PSL200280	15.47 x 3.53	120.0	99.5	8.1	PSL401200	98 x 7.00
30.0	19.3	4.2	PSL200300	18.66 x 3.53	125.0	109.9	6.3	PSL301250	107.32 x 5.33
32.0	21.3	4.2	PSL200320	20.22 x 3.53	125.0	104.5	8.1	PSL401250	103 x 7.00
35.0	24.3	4.2	PSL200350	23.40 x 3.53	130.0	114.9	6.3	PSL301300	113.67 x 5.33
40.0	29.3	4.2	PSL200400	28.17 x 3.53	130.0	109.5	8.1	PSL401300	108 x 7.00
42.0	31.3	4.2	PSL200420	29.75 x 3.53	135.0	114.5	8.1	PSL401350	113.67 x 7.00
45.0	34.3	4.2	PSL200450	32.92 x 3.53	140.0	119.5	8.1	PSL401400	116.84 x 7.00
48.0	37.3	4.2	PSL200480	36.09 x 3.53	145.0	124.5	8.1	PSL401450	123.19 x 7.00
50.0	39.3	4.2	PSL200500	37.69 x 3.53	150.0	129.5	8.1	PSL401500	126.37 x 7.00
50.0	34.9	6.3	PSL300500	32.69 x 5.33	155.0	139.9	6.3	PSL301550	135.89 x 5.33
52.0	41.3	4.2	PSL200520	40.87 x 3.53	160.0	144.9	6.3	PSL301600	142.24 x 5.33
55.0	44.3	4.2	PSL200550	44.04 x 3.53	160.0	139.5	8.1	PSL401600	135.89 x 7.00
55.0	39.9	6.3	PSL300550	37.47 x 5.33	165.0	149.9	6.3	PSL301650	148.49 x 5.33
60.0	44.9	6.3	PSL300600	43.82 x 5.33	165.0	144.5	8.1	PSL401650	142.24 x 7.00
62.0	51.3	4.2	PSL200620	50.39 x 3.53	170.0	149.5	8.1	PSL401700	145.42 x 7.00
63.0	52.3	4.2	PSL200630	50.39 x 3.53	175.0	159.9	6.3	PSL301750	158.12 x 5.33
63.0	47.9	6.3	PSL300630	46.99 x 5.33	180.0	164.9	6.3	PSL301800	164.47 x 5.33
65.0	49.9	6.3	PSL300650	46.99 x 5.33	180.0	159.5	8.1	PSL401800	158.12 x 7.00
70.0	59.3	4.2	PSL200700	56.74 x 3.53	190.0	174.9	6.3	PSL301900	170.82 x 5.33
70.0	54.9	6.3	PSL300700	53.34 x 5.33	190.0	169.5	8.1	PSL401900	164.47 x 7.00
70.0	49.5	8.1	PSL400700	48 x 7.00	195.0	174.5	8.1	PSL401950	170.82 x 7.00
75.0	59.9	6.3	PSL300750	56.52 x 5.33	200.0	184.9	6.3	PSL302000	183.52 x 5.33
80.0	64.9	6.3	PSL300800	62.87 x 5.33	200.0	179.5	8.1	PSL402000	177.17 x 7.00
80.0	59.5	8.1	PSL400800	58 x 7.00	205.0	184.5	8.1	PSL402050	183.52 x 7.00
85.0	69.9	6.3	PSL300850	69.22 x 5.33	210.0	189.5	8.1	PSL402100	183.52 x 7.00
85.0	64.5	8.1	PSL400850	63 x 7.00	220.0	204.9	6.3	PSL302200	202.57 x 5.33
90.0	74.9	6.3	PSL300900	72.39 x 5.33	220.0	199.5	8.1	PSL402200	196.22 x 7.00
90.0	69.5	8.1	PSL400900	68 x 7.00	230.0	209.5	8.1	PSL402300	208.90 x 7.00
95.0	79.9	6.3	PSL300950	78.74 x 5.33	240.0	219.5	8.1	PSL402400	215.27 x 7.00
95.0	74.5	8.1	PSL400950	73 x 7.00	250.0	229.5	8.1	PSL402500	227.97 x 7.00
100.0	84.9	6.3	PSL301000	81.92 x 5.33	250.0	226.0	8.1	PSL802500	227.97 x 7.00
100.0	79.5	8.1	PSL401000	78 x 7.00	260.0	236.0	8.1	PSL802600	227.97 x 7.00
105.0	89.9	6.3	PSL301050	88.27 x 5.33	270.0	246.0	8.1	PSL802700	240.67 x 7.00
105.0	84.5	8.1	PSL401050	83 x 7.00	280.0	256.0	8.1	PSL802800	253.37 x 7.00
106.0	90.9	6.3	PSL301060	88.27 x 5.33	300.0	276.0	8.1	PSL803000	266.07 x 7.00
110.0	94.9	6.3	PSL301100	91.44 x 5.33	306.0	285.5	8.1	PSL403060	278.77 x 7.00
110.0	89.5	8.1	PSL401100	88 x 7.00	310.0	286.0	8.1	PSL803100	278.77 x 7.00



Bore Dia.	Groove Dia.	Groove Width	TSS Part No.	O-Ring Dimensions
D_N H9	d_1 h9	L_1 +0.2		
320.0	299.5	8.1	PSL403200	291.47 x 7.00
320.0	296.0	8.1	PSL803200	291.47 x 7.00
330.0	306.0	8.1	PSL803300	304.17 x 7.00
340.0	316.0	8.1	PSL803400	316.87 x 7.00
345.0	324.5	8.1	PSL403450	316.87 x 7.00
350.0	326.0	8.1	PSL803500	316.87 x 7.00
360.0	336.0	8.1	PSL803600	329.57 x 7.00
370.0	346.0	8.1	PSL803700	342.27 x 7.00
380.0	356.0	8.1	PSL803800	354.97 x 7.00
400.0	376.0	8.1	PSL804000	367.67 x 7.00
420.0	396.0	8.1	PSL804200	393.07 x 7.00
430.0	406.0	8.1	PSL804300	405.26 x 7.00
440.0	416.0	8.1	PSL804400	405.26 x 7.00
450.0	426.0	8.1	PSL804500	417.96 x 7.00
480.0	456.0	8.1	PSL804800	456.06 x 7.00
500.0	476.0	8.1	PSL805000	468.76 x 7.00
520.0	499.5	8.1	PSL405200	494.16 x 7.00
540.0	516.0	8.1	PSL805400	506.86 x 7.00
600.0	576.0	8.1	PSL806000	557.66 x 7.00
650.0	626.0	8.1	PSL806500	608.08 x 7.00

Bore Dia.	Groove Dia.	Groove Width	TSS Part No.	O-Ring Dimensions
D_N H9	d_1 h9	L_1 +0.2		
700.0	672.7	9.5	PSL507000	670 x 8.40
780.0	752.7	9.5	PSL507800	750 x 8.40
800.0	772.7	9.5	PSL508000	770 x 8.40
820.0	792.7	9.5	PSL508200	790 x 8.40
860.0	832.7	9.5	PSL508600	830 x 8.40
900.0	872.7	9.5	PSL509000	870 x 8.40
920.0	892.7	9.5	PSL509200	890 x 8.40
1,000.0	972.7	9.5	PSL5X1000	970 x 8.40
1,000.0	962.0	13.8	PSL6X1000	960 x 12.00
1,200.0	1,172.7	9.5	PSL5X1200	1,171 x 8.40
1,200.0	1,162.0	13.8	PSL6X1200	1,160 x 12.00
1,500.0	1,462.0	13.8	PSL6X1500	1,460 x 12.00
2,000.0	1,962.0	13.8	PSL6X2000	1,960 x 12.00
2,650.0	2,612.0	13.8	PSL6X2650	2,610 x 12.00
2,700.0	2,662.0	13.8	PSL6X2700	2,660 x 12.00

The bore diameters in **bold** type comply with the recommendations of ISO 3320.

Other dimensions and all intermediate sizes up to 2,700 mm diameter including imperial (inch) sizes can be supplied.

All O-Rings with 12 mm cross section are delivered as special profile ring.

Turcon® Double Delta®



Double-acting

Rubber-energized plastic-faced seal

For O-Ring Grooves

Material:

Turcon®, Zurcon® and Elastomer



! This page is intentionally left blank.



Turcon® Double Delta®



Description

Turcon® Double Delta® is a rubber energized plastic faced seal, designed to expand and significantly improve the service parameters of O-Rings. Double Delta® can be installed in existing O-Ring grooves.

Double Delta® combines the flexibility and responsiveness of O-Rings with the wear and friction characteristics of the Turcon® materials in dynamic applications.

The double-acting performance of the seal follows from the symmetrical cross section which allows the seal to respond to pressure in both directions - Figure 131.

Initial contact pressure is provided by radial compression of the O-Ring. When the system pressure is increased the O-Ring transforms this into additional contact pressure, the contact pressure of the seal is thereby automatically adjusted so sealing is ensured under all service conditions.

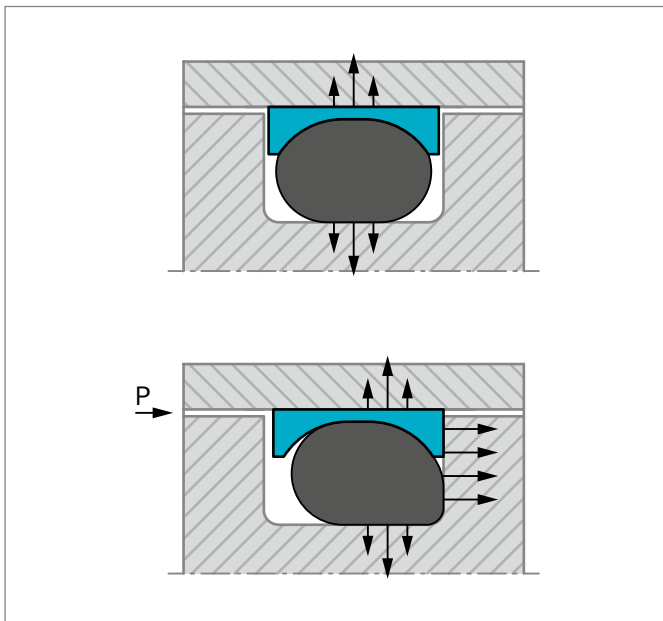

Figure 131: Turcon® Double Delta® without and with pressure

ADVANTAGES

- Compact groove dimensions and simple installation
- Low friction without stick-slip
- Resistance against wear and extrusion
- Piston seals available for all diameters from 5 to 999.9 mm

- Standard cross section cover AS 568A and important metric O-Rings, other cross sections available on request.
- Fits also groove dimensions per ISO 6194 and AS 4716

APPLICATION EXAMPLES

Turcon® Double Delta® is used as double acting piston seal for hydraulic and pneumatic cylinders in applications such as:

- Machine tools
- Handling devices
- Valves
- Chemical process equipment

It is particular recommended for light duty and small diameter applications.

OPERATING CONDITIONS

Pressure:	Up to 35 MPa
Velocity:	Up to 15 m/s
Temperature:	-45 °C to +200 °C* (according to O-Ring material)
Media:	Mineral oil-based hydraulic fluids, flame retardant hydraulic fluids, environmentally friendly hydraulic fluids (bio-oils), phosphate ester, water and others, depending on temperature, seal and O-Ring material compatibility see Table 116
Clearance:	The maximum permissible radial clearance S_{max} is shown in Table 117, as a function of the operating pressure and functional diameter

IMPORTANT NOTE

The above data are maximum values and cannot be used at the same time, e.g. the maximum operating speed depends on material type, pressure, temperature and gap value. Temperature range also depends on media.

* In the case of unpressurized piston applications in temperatures below 0 °C please contact your local Customer Solution Center for more information!



NOTCH

Turcon® Double Delta® is as standard supplied without radial notches, as the thin radial section of the seal gives good response to pressure variations.

For diameters from 8 mm notches on both sides are optional. These ensure direct pressurizing of the seal under all operating conditions.

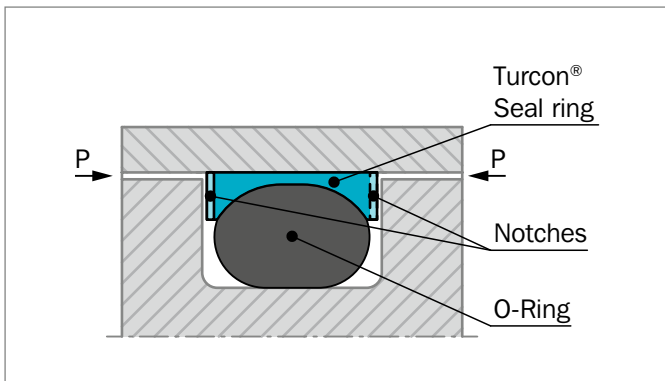

Figure 132: Turcon® Double Delta® with notches

INSTALLATION INSTRUCTIONS

Double Delta® is installed according to information on page 247 to 249.

RECOMMENDED MATERIALS

The following material combinations have proven effective for hydraulic applications:

Turcon® Double Delta® in Turcon® M12

All round material for light to medium hydraulic applications with linear or helical movements in mineral oils, flame retardant hydraulic fluids, phosphate ester, bio-oils or fluids having low lubricating properties:

O-Ring:	NBR 70 Shore A	N
	FKM 70 Shore A	V
	EPDM 70 Shore A	E

Set code: M12N, M12V or M12E

Turcon® Double Delta® in Turcon® T46

For medium to heavy applications with linear movements in mineral oils and other media with good lubrication:

O-Ring:	NBR 70 Shore A	N
	FKM 70 Shore A	V

Set code: T46N or T46V

For specific applications, all Turcon® materials are available. Other material combinations are listed in Table 116.

**Table 116: Turcon® and Zurcon® Materials for Double Delta®**

Material, Applications, Properties	Code	O-Ring Material Shore A	Code	O-Ring Operating Temp.* °C	Mating Surface Material	MPa max. Dynamic
Turcon® M12 First material choice for seals in linear motion Overall improved properties For new constructions and updating For all commonly applied hydraulic fluids including fluids with low lubrication performance Lowest friction and best sliding properties Lowest wear on seals Improved absorption of abrasive contaminants Low wear or abrasion of counter surface BAM tested Mineral fiber and Additives filled Color: Dark gray	M12	NBR 70	N	-30 to +100	Steel	35
		NBR 70 Low temp.	T	-45 to +80	Steel hardened Cast iron	
		FKM 70	V	-10 to +20	Stainless steel Titanium	
Turcon® T05 For lubricating fluids Also for gas service Very low friction Very good sliding and sealing properties Color: Turquoise	T05	NBR 70	N	-30 to +100	Steel	20
		NBR 70 Low temp.	T	-45 to +80	Steel hardened	
		FKM 70	V	-10 to +200		
Turcon® T24 For lubricating and non-lubricating hydraulic fluids Good sealing function Moderate extrusion resistance Carbon filled Color: Black	T24	NBR 70	N	-30 to +100	Steel	20
		NBR 70 Low temp.	T	-45 to +80	Steel hardened Cast iron	
		FKM 70	V	-10 to +200	Stainless steel	
		EPDM 70	E**	-45 to +145	Aluminum	
Turcon® T46 For lubricated hydraulics in linear motion High compressive strength High extrusion resistance Very good sliding and wear properties BAM tested Bronze filled Color: Light to dark brown, which may have variations in shading	T46	NBR 70	N	-30 to +100	Steel hardened	35
		NBR 70 Low temp.	T	-45 to +80	Cast iron	
		FKM 70	V	-10 to +200		
Zurcon® Z80 For lubricating and non-lubricating fluids Water based fluids, air and gases Dry air pneumatics High abrasion and extrusion resistance For service in abrasive conditions and media with particles Good chemical resistance Limited temperature capability (-60 to +80 °C) UHMWPE (Ultra High Molecular Weight PE) Color: White to off-white	Z80	NBR 70	N	-30 to (+100)	Steel	30
		NBR 70 Low temp.	T	-45 to +80	Steel hardened Stainless steel	
		EPDM 70	E**	-10 to (+145)	Aluminum Ceramic coating	

* The O-Ring Operation Temperature is only valid in mineral hydraulic oil (except EPDM).

** Material not suitable for mineral oils.

BAM: Tested by "Bundesanstalt Materialprüfung, Germany".

Highlighted materials are recommended.



Installation Recommendation

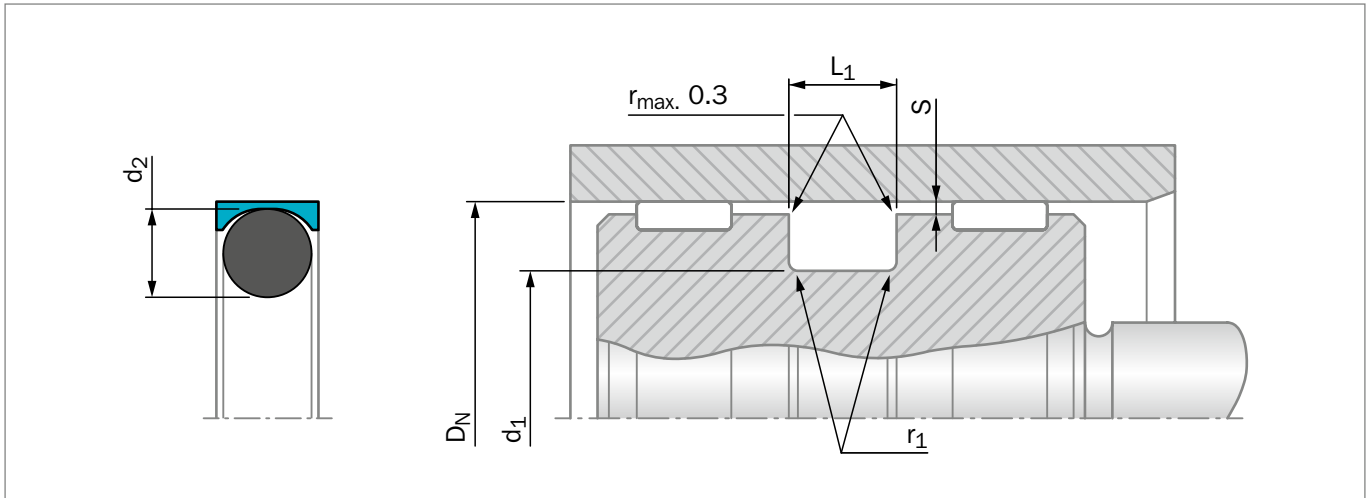

Figure 133: Installation Drawing

Table 117: Installation Dimensions

Series No.	Bore Diameter D_N H9		Groove Diameter d_1 h9	Groove Width L_1 +0.2	Radius r_1 max	Radial Clearance S_{max}^*				O-Ring Cross Section d_2
	Standard Application	Available Range				2 MPa	10 MPa	20 MPa	35 MPa	
PDD0	5 - 13.9	5 - 139.9	$D_N - 2.9$	2.4	0.4	0.10	0.10	0.08	0.05	1.78
PDD1	14 - 24.9	8 - 259.9	$D_N - 4.5$	3.6	0.4	0.15	0.15	0.10	0.07	2.62
PDD2	25 - 45.9	12 - 469.9	$D_N - 6.2$	4.8	0.6	0.25	0.20	0.15	0.08	3.53
PDD3	46 - 124.9	20 - 669.9	$D_N - 9.4$	7.1	0.8	0.35	0.25	0.20	0.10	5.33
PDD4	125 - 669.9	80 - 999.9	$D_N - 12.2$	9.5	0.8	0.50	0.30	0.25	0.15	7.00
PDD5	670 - 999.9	125 - 999.9	$D_N - 15.0$	10.0	1.0	0.60	0.40	0.30	0.20	8.40

* Slydring® / Wear Rings are not applicable at very small radial clearances please consult the Slydring® section in this catalog.

ORDERING EXAMPLE

Double Delta® complete with O-Ring, standard application:

Series:	PDD3 from Table 117
Bore Diameter:	$D_N = 80.0$ mm
TSS Part No.:	PDD300800 from Table 118

Select the material from Table 116. The corresponding code numbers are appended to the Part No. Together these form the TSS Article Number. The TSS Article Number for all intermediate sizes can be determined by following the example:

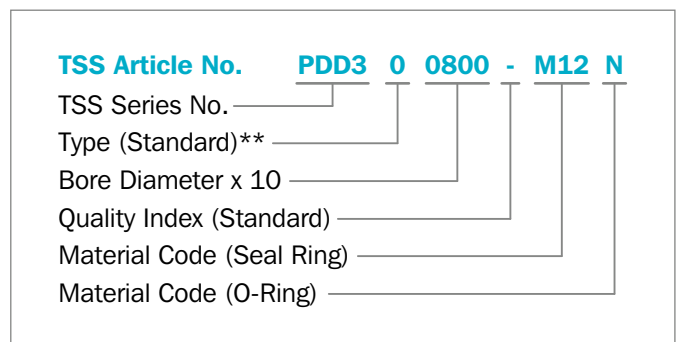

** "N" for seals with notches. Available for diameters $D_N \geq 8.0$ mm.

For seals for other groove widths/dimensions please refer to Table 119 and Table 120



Table 118: Installation Dimensions / TSS Part No.

Bore Dia.	Groove Dia.	Groove Width	TSS Part No.	O-Ring Dimensions	Bore Dia.	Groove Dia.	Groove Width	TSS Part No.	O-Ring Dimensions
D _N H9	d ₁ h9	L ₁ +0.2			D _N H9	d ₁ h9	L ₁ +0.2		
6.0	3.1	2.4	PDD000060	2.57 x 1.78	110.0	100.6	7.1	PDD301100	97.79 x 5.33
8.0	5.1	2.4	PDD000080	4.47 x 1.78	115.0	105.6	7.1	PDD301150	104.14 x 5.33
9.0	6.1	2.4	PDD000090	5.60 x 1.80	120.0	110.6	7.1	PDD301200	107.32 x 5.33
10.0	7.1	2.4	PDD000100	6.70 x 1.80	125.0	112.8	9.5	PDD401250	113.67 x 7.00
11.0	8.1	2.4	PDD000110	7.65 x 1.78	130.0	117.8	9.5	PDD401300	116.84 x 7.00
12.0	9.1	2.4	PDD000120	8.75 x 1.80	135.0	122.8	9.5	PDD401350	120.02 x 7.00
12.7	9.8	2.4	PDD000127	9.25 x 1.78	140.0	127.8	9.5	PDD401400	126.37 x 7.00
14.0	9.5	3.6	PDD100140	9.19 x 2.62	150.0	137.8	9.5	PDD401500	135.89 x 7.00
15.0	10.5	3.6	PDD100150	9.19 x 2.62	160.0	147.8	9.5	PDD401600	145.42 x 7.00
16.0	11.5	3.6	PDD100160	10.77 x 2.62	170.0	157.8	9.5	PDD401700	151.77 x 7.00
18.0	13.5	3.6	PDD100180	12.37 x 2.62	180.0	167.8	9.5	PDD401800	164.47 x 7.00
20.0	15.5	3.6	PDD100200	14.50 x 2.65	190.0	177.8	9.5	PDD401900	177.17 x 7.00
22.0	17.5	3.6	PDD100220	17.12 x 2.62	200.0	187.8	9.5	PDD402000	183.52 x 7.00
24.0	19.5	3.6	PDD100240	18.72 x 2.62	210.0	197.8	9.5	PDD402100	196.22 x 7.00
25.0	18.8	4.8	PDD200250	17.04 x 3.53	220.0	207.8	9.5	PDD402200	202.57 x 7.00
25.4	19.2	4.8	PDD200254	18.66 x 3.53	230.0	217.8	9.5	PDD402300	215.27 x 7.00
27.0	20.8	4.8	PDD200270	20.22 x 3.53	240.0	227.8	9.5	PDD402400	227.97 x 7.00
28.0	21.8	4.8	PDD200280	20.22 x 3.53	250.0	237.8	9.5	PDD402500	227.97 x 7.00
30.0	23.8	4.8	PDD200300	23.40 x 3.53	280.0	267.8	9.5	PDD402800	266.07 x 7.00
32.0	25.8	4.8	PDD200320	25.00 x 3.53	300.0	287.8	9.5	PDD403000	278.77 x 7.00
35.0	28.8	4.8	PDD200350	28.17 x 3.53	320.0	307.8	9.5	PDD403200	304.17 x 7.00
40.0	33.8	4.8	PDD200400	32.92 x 3.53	350.0	337.8	9.5	PDD403500	329.57 x 7.00
42.0	35.8	4.8	PDD200420	34.52 x 3.53	400.0	387.8	9.5	PDD404000	380.37 x 7.00
45.0	38.8	4.8	PDD200450	37.69 x 3.53	420.0	407.8	9.5	PDD404200	405.26 x 7.00
48.0	38.6	7.1	PDD300480	37.47 x 5.33	450.0	437.8	9.5	PDD404500	430.66 x 7.00
50.0	40.6	7.1	PDD300500	37.47 x 5.33	480.0	467.8	9.5	PDD404800	456.06 x 7.00
50.8	41.4	7.1	PDD300508	40.64 x 5.33	500.0	487.8	9.5	PDD405000	481.38 x 7.00
52.0	42.6	7.1	PDD300520	40.64 x 5.33	600.0	587.8	9.5	PDD406000	582.68 x 7.00
55.0	45.6	7.1	PDD300550	43.82 x 5.33	650.0	637.8	9.5	PDD406500	633.48 x 7.00
56.0	46.6	7.1	PDD300560	43.82 x 5.33					
60.0	50.6	7.1	PDD300600	50.17 x 5.33					
63.0	53.6	7.1	PDD300630	53.34 x 5.33					
65.0	55.6	7.1	PDD300650	53.34 x 5.33					
70.0	60.6	7.1	PDD300700	59.69 x 5.33					
75.0	65.6	7.1	PDD300750	62.87 x 5.33					
80.0	70.6	7.1	PDD300800	69.22 x 5.33					
85.0	75.6	7.1	PDD300850	72.39 x 5.33					
90.0	80.6	7.1	PDD300900	78.74 x 5.33					
95.0	85.6	7.1	PDD300950	81.92 x 5.33					
100.0	90.6	7.1	PDD301000	88.27 x 5.33					

The bore diameters in **bold** type comply with the recommendations of ISO 3320.

TSS Part No. for other dimensions and all intermediate dimensions up to 999.9 mm diameter including imperial (inch) dimensions can be supplied. Larger dimensions up to 2,700 mm available upon request.



Turcon® Double Delta® for one Back-up Ring grooves

Double Delta® is available for designs where grooves for O-Ring with one Back-up Ring are used according to Table 119.

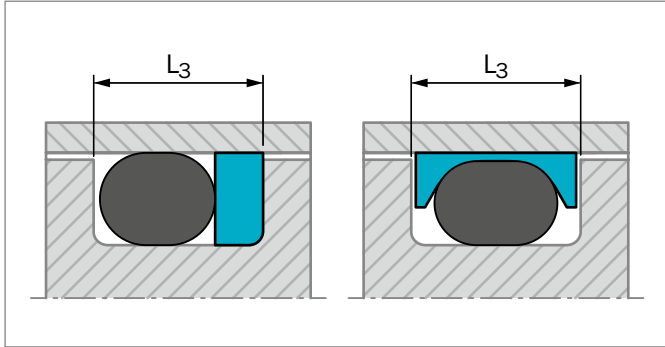

Figure 134: Groove width

ORDERING EXAMPLE

Double Delta® complete with O-Ring, standard application:

Bore Diameter:	$D_N = 80 \text{ mm}$
Groove Diameter:	70.6 mm
Groove Width:	8.5 mm
TSS Article No.:	PDA300800-M12N

Table 119: Seals for one Back-up Ring groove

Series No.	Groove Width	Execution Mark 5th digit		O-Ring Cross Section
	L_3	Without Notch	With Notch*	d_2
PDA0	3.80	0	N	1.78
PDA1	4.65	0	N	2.62
PDA2	5.70	0	N	3.53
PDA3	8.50	0	N	5.33
PDA4	11.20	0	N	7.00
PDA5	12.50	0	N	8.40

* Available for diameters from 8 mm

TSS Article No. **PDA3** **0** **0800** - **M12** **N**

TSS Series No.** _____

Type (Standard)*** _____

Bore Diameter x 10 _____

Quality Index (Standard) _____

Material Code (Seal Ring)**** _____

Material Code (O-Ring)***** _____

** From Table 119 or Table 120

*** N for seals with notches, available from diameter 8.0 mm

**** From Table 116

***** From Table 116

Turcon® Double Delta® for metric O-Rings

Double Delta® is available for installation in grooves for metric O-Rings as listed in Table 120.

Table 120: Piston Seals for Metric O-Ring Grooves

O-Ring Cross Section d_2	Groove Diameter d_1 h9	Groove Width L_1 +0.2	Series No.	Execution Mark 5th digit		Available Range
				Standard	Notch*	
2.0	$D_N - 3.3$	2.7	PD2A	0	N	6 - 100.0
2.4	$D_N - 4.1$	3.2	PD2E	0	N	8 - 160.0
2.5	$D_N - 4.3$	3.3	PD2F	0	N	8 - 160.0
3.0	$D_N - 5.2$	4.0	PD3A	0	N	12 - 200.0
4.0	$D_N - 7.0$	5.2	PD4A	0	N	16 - 300.0
5.0	$D_N - 8.8$	6.6	PD5A	0	N	20 - 400.0
5.7	$D_N - 10.0$	7.2	PD5H	0	N	20 - 669.9

* Available for diameters from 8 mm

Turcon® Variseal® M2



Single-acting

Spring-energized plastic-U-Cup

Material:

Turcon® and Zurcon®



! This page is intentionally left blank.



Turcon® Variseal® M2



Description

Turcon® Variseal® M2 is a single-acting seal consisting of a U-shaped jacket and a V-shaped corrosion resistant spring. Variseal® M2 has an asymmetric seal profile. The optimized front angle offers good leakage control, reduced friction and long service life.

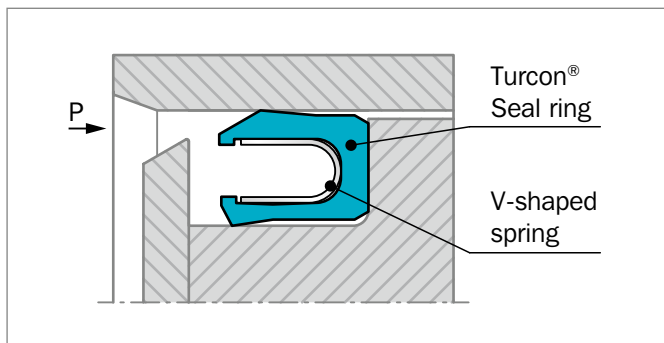

Figure 135: Turcon® Variseal® M2

AREAS OF APPLICATION

- Hydraulic components, e.g. cylinders, valves, pumps, etc.
- Chemical processing equipment
- Pharmaceutical processing
- Food and beverage processing
- Spindle seals for machine tools
- Pneumatics, cylinders and valves

ADVANTAGES

- Suitable for reciprocating and rotary applications
- Low coefficient of friction
- Stick-slip free operating
- High abrasion resistance
- Dimensionally stable
- Resistant to most fluids, chemicals and gases
- Withstands rapid changes in temperature
- No vulcanizing between seal and hardware
- Excellent resistance to aging
- Can be sterilized
- Available in HiClean version
- Interchangeable with O-Ring and Back-up Ring combinations to AS4716 and ISO 6194

OPERATING CONDITIONS

Operating Pressure:	Maximum dynamic load: 20 MPa Maximum static load: 40 MPa (200 MPa with back-up ring)
Speed:	Reciprocating up to 15 m/s Rotating up to 1.3 m/s
Operating Temperature:	-70 °C to +300 °C Special Turcon® and Zurcon® materials as well as alternative spring materials are available for applications outside this temperature range.
Media Compatibility:	Virtually all fluids, chemicals and gases

IMPORTANT NOTE

The above data are maximum values and cannot be used at the same time. e.g. the maximum operating speed depends on material type, pressure, temperature and value.

Temperature range also dependent on media.



GENERAL

Turcon® Variseal® are single acting, spring-energized seals which are used for dynamic and static applications.

Variseal® are effective in a wide range of applications. They are chosen when higher resistance to chemical media is required, if the seal is required to operate in extremes of temperature and/or where good extrusion and compression characteristics are needed.

Turcon® Variseal® designs have three main characteristics:

- Application specific U-shaped seal profile
- Spring geometry suited to the particular application
- Proven high-performance Turcon® or Zurcon® polymers

Standard or custom geometries available in metric, inch and intermediate sizes ranging from 2 to 3,300 mm.

METHOD OF OPERATION

All Variseal® designs included in this catalog have the same operating principle and differ only in their profile form and type of metallic spring used.

The Variseal® spring supplies the load required for sealing at low pressures (Figure 136). The "U" shaped jacket allows fluid pressure to energize the sealing lips, so total sealing pressure rises with increasing operating pressure (Figure 137).

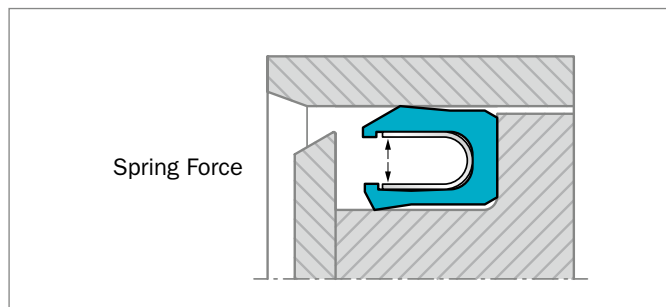

Figure 136: Turcon® Variseal® without system pressure

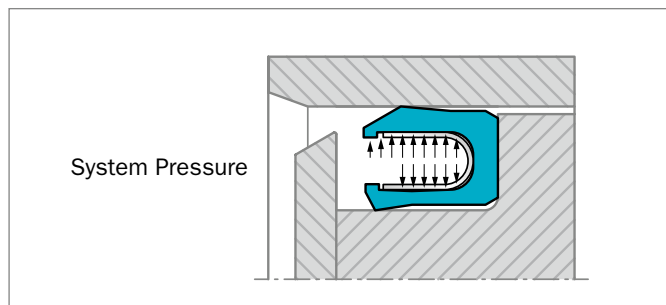

Figure 137: Turcon® Variseal® with system pressure

PERFORMANCE

The different types of Variseal® designs combined with the properties of Turcon® and Zurcon® materials offer design engineers a wide range of solutions to a large number of applications.

The most important characteristics of Variseal® designs are listed below:

- Very low coefficient of friction
- Good dynamic and static sealing
- Capable of sealing at high speeds up to 15 m/s
- Almost universal chemical compatibility
- Operating temperature of -253 °C up to +300 °C
- Very good thermal resistance
- Properties unaffected by contact with chemicals
- Good aging characteristics
- Low compression set
- Capable of withstanding high pressures above 200 MPa (2,000 bar) when using Back-up Rings
- Very good dry-running properties
- Can be installed in grooves according to AS4716 (Mil-G-5514 is an old spec) and DIN 3771



MATERIALS

All materials used are physiologically safe. They contain no odor or taste-affecting substances.

The following material combination has proved effective for most fluid applications:

Seal ring: Turcon® T40
 Spring: Stainless steel, Material No. AISI 301
 Material code S

For gas applications use:
 Seal ring: T05 or Z80

For use in accordance with the demands of the Food and Drug Administration, suitable materials are available on request.

Table 121: Turcon® and Zurcon® Materials for Variseal® M2

Material Code Material Description	Operating Temperature* °C	Mating Surface Material	MPa max.
Turcon® T05 Premium grade modified PTFE. Light duty material with greater wear resistance than Turcon T01. Reciprocating and slow rotary applications. Color: Turquoise	-200 to + 260	Steel Steel chrome plated Cast iron Stainless steel Aluminum Bronze Alloys	20
Turcon® T40 High-grade formulation of virgin polytetrafluoroethylene (PTFE) based material compounded with carbon fiber additive. Excellent wear and low friction characteristics. Suited to reciprocating and rotary applications. Suitable for use in media with poor lubricating properties and for dry-running situations. Color: Black / gray	-60 to + 300	Steel Steel hardened Steel chrome plated	40
Zurcon® Z80 UHMW Polyethylene. Excellent wear and abrasion resistance. Very good lubricity in water based media. Color: Translucent white	-250 to +80	Steel Steel chrome plated Stainless steel Aluminum Bronze Ceramic coating	40

* Depending on media.

Highlighted material is standard.

Installation of Spring Energized Seals

See page 247



SPRING MATERIALS

The standard spring material for Turcon® Variseal® is stainless steel (spring code S).

Table 122: Spring Material

Media	Spring materials	Spring order code
For General use e.g. Oil Grease Air Water, steam Solvents Food, drugs Gas	Stainless steel DIN Mat No. 1.4310/1.4319 AISI 301/302 UNS 30100	S (Standard spring material)
For use in corrosive media e.g. Acids Caustics Seawater	Hastelloy® C-276 DIN Mat No. 2.4819 UNS N10276	H
For petrochemical use e.g. Crude oil Sour gas	Elgiloy® 1) DIN Mat No. 2.4711 UNSR30003	E

* Hastelloy is a registered trademark of Haynes International, Inc.

* Elgiloy is a registered trademark of the Elgiloy Specialty Metals
 Alternative brand may be used.

1) NACE-approval



■ Groove Design – Metric

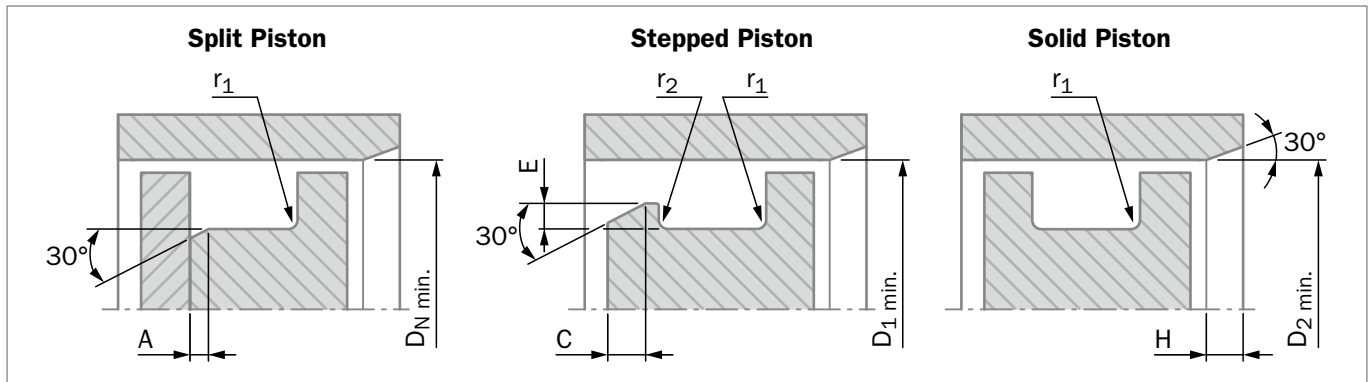

Figure 138: Variseal Groove Configurations

Installation lead-in chamfers and steps to include blend radii and are to be polished.

Table 123: Dimensions for Groove Designs – Metric

Series	Rod / Piston Groove Dimensions					
	A Chamfer	r ₁ Maximum Radius	C Minimum Chamfer	r ₂ Maximum Radius	E Minimum Step Height	H Minimum Chamfer
000	0.25 / 0.38	0.25	0.70	0.13	0.40	1.20
100	0.38 / 0.51	0.38	1.10	0.13	0.60	1.50
200	0.38 / 0.51	0.38	1.25	0.18	0.70	2.50
300	0.51 / 0.69	0.38	1.40	0.25	0.80	4.50
400	0.51 / 0.69	0.51	1.60	0.25	0.90	6.00
500	0.76 / 1.02	0.51	2.60	0.38	1.50	11.00

Table 124: Dimensions for Groove Designs – Metric

Series	Piston Diameter Recommendations		
	Split Groove Ø D _N Minimum	Stepped Groove Ø D ₁ Minimum	Solid Groove Ø D ₂ Minimum
000	6.00	11.50	34.93
100	10.00	17.50	50.80
200	16.00	20.00	69.85
300	28.00	28.00	104.78
400	45.00	45.00	139.70
500	100.00	100.00	254.00



■ Installation Recommendation

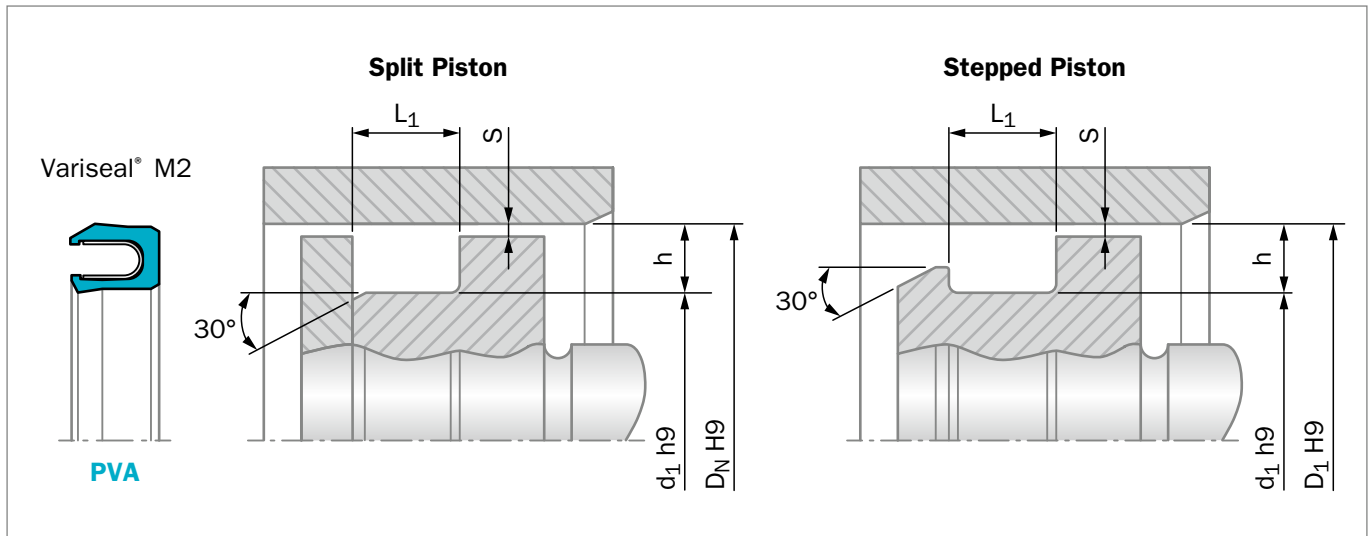

Figure 139: Installation Drawing, see Figure 138 for addition groove details

Table 125: Installation Dimensions

Series No.	Bore Diameter D_N/D_1 H9		Groove Diameter d_1 h9	Groove Width L_1 +0.2	Radial Clearance S_{max} *			
	Standard Range	Extended**			<2 MPa	<10 MPa	<20 MPa	<40 MPa
PVA0	6 - 13.9	6 - 40	$D_N/D_1 - 2.9$	2.4	0.20	0.10	0.08	0.05
PVA1	14 - 24.9	10 - 200	$D_N/D_1 - 4.5$	3.6	0.25	0.15	0.10	0.07
PVA2	25 - 45.9	16 - 400	$D_N/D_1 - 6.2$	4.8	0.35	0.20	0.15	0.08
PVA3	46 - 124.9	28 - 700	$D_N/D_1 - 9.4$	7.1	0.50	0.25	0.20	0.10
PVA4	125 - 999.9	45 - 1,600	$D_N/D_1 - 12.2$	9.5	0.60	0.30	0.25	0.12
PVA5	1,000 - 2,500	100 - 2,500	$D_N/D_1 - 19.0$	15.0	0.90	0.50	0.40	0.20

* We recommend that the gap dimensions be reduced for temperatures ≥ 80 °C.

At pressures > 40 MPa a Back-up Ring would be incorporated and the extrusion gap would not be considered.

** Available on request.

**Table 126: Installation Dimensions / TSS Part No.**

D_N	d_1	TSS Part No.	D_N	d_1	TSS Part No.	D_N	d_1	TSS Part No.
6.0	3.1	PVA0_0060	45.0	38.8	PVA2_0450	115.0	105.6	PVA3_1150
8.0	5.1	PVA0_0080	48.0	38.6	PVA3_0480	120.0	110.6	PVA3_1200
10.0	7.1	PVA0_0100	50.0	40.6	PVA3_0500	125.0	112.8	PVA4_1250
12.0	9.1	PVA0_0120	52.0	42.6	PVA3_0520	130.0	117.8	PVA4_1300
14.0	9.5	PVA1_0140	55.0	45.6	PVA3_0550	135.0	122.8	PVA4_1350
15.0	10.5	PVA1_0150	60.0	50.6	PVA3_0600	140.0	127.8	PVA4_1400
16.0	11.5	PVA1_0160	63.0	53.6	PVA3_0630	150.0	137.8	PVA4_1500
18.0	13.5	PVA1_0180	65.0	55.6	PVA3_0650	160.0	147.8	PVA4_1600
20.0	15.5	PVA1_0200	70.0	60.6	PVA3_0700	170.0	157.8	PVA4_1700
22.0	17.5	PVA1_0220	75.0	65.6	PVA3_0750	180.0	167.8	PVA4_1800
25.0	18.8	PVA2_0250	80.0	70.6	PVA3_0800	190.0	177.8	PVA4_1900
28.0	21.8	PVA2_0280	85.0	75.6	PVA3_0850	200.0	187.8	PVA4_2000
30.0	23.8	PVA2_0300	90.0	80.6	PVA3_0900	210.0	197.8	PVA4_2100
32.0	25.8	PVA2_0320	95.0	85.6	PVA3_0950	220.0	207.8	PVA4_2200
35.0	28.8	PVA2_0350	100.0	90.6	PVA3_1000	230.0	217.8	PVA4_2300
40.0	33.8	PVA2_0400	105.0	95.6	PVA3_1050	240.0	227.8	PVA4_2400
42.0	35.8	PVA2_0420	110.0	100.6	PVA3_1100	250.0	237.8	PVA4_2500

ORDERING EXAMPLE

Turcon® Variseal® M2, standard range:

Series:	PVA3 from Table 125
Bore Diameter:	$D_N = 80.0$ mm
TSS Part No.:	PVA300800
Spring Material:	Stainless steel
Spring Load:	Medium

Select the material from Table 121. The corresponding code numbers are appended to the TSS Part No. from Table 126. Together they form the TSS Article No. For all intermediate sizes not shown in Table 126, the TSS Article No. can be determined from the example opposite.

TSS Article No. PVA3 0 0800 - T40 S M

TSS Series No.	PVA3
Type (Standard)	0
Bore Diameter x 10**	0800
Quality Index (Standard)	-
Material Code (Seal Ring)	T40
Material Code (Spring)	S
Spring Load***	M

** For diameters $D_N \geq 1,000.0$ mm multiply only by factor 1.Example: PVA5 for diameter $D_N = 1,200.0$ mmTSS Article No.: PVA5X**1200** - T40SM

*** M Medium, R HiClean

! This page is intentionally left blank.

Turcon® VL Seal®



Single-acting

Rubber-energized plastic-faced seal

Material:

Turcon®, Zurcon® and Elastomer



! This page is intentionally left blank.



■ Turcon® VL Seal®*



■ Description

Turcon® VL Seal® is a new generation unidirectional Piston seal for the same groove dimensions as standard O-Rings, Figure 140.

The design is optimized with regard to performance, friction, leakage and service life through meticulous simulation, in-house testing and qualification in customer applications.

VL Seal® effectively provides static sealing by the O-Ring. The O-Ring is protected from damage under pressure cycles by the contoured O-Ring contact zone which supports the O-Ring and keeps it in position also at high working pressure.

VL Seal® is designed with hydrodynamic back-pumping effect which allows the seal to relieve pressure trapped between seals in tandem configuration.

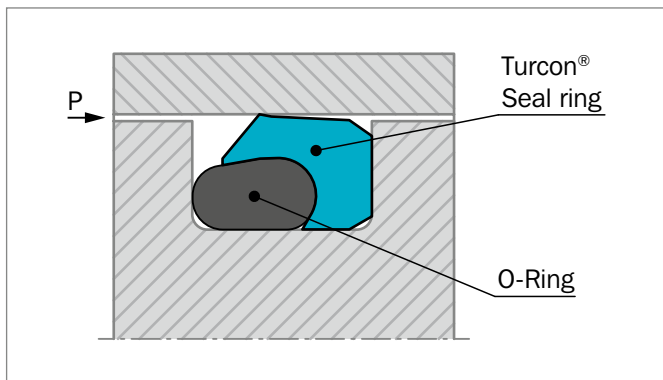

Figure 140: Turcon® VL Seal® mounted in O-Ring groove

METHOD OF OPERATION

The sealing mechanism of VL Seal® is based on the hydrodynamic properties of the seal. The specially formed seal edge has a steep contact pressure gradient on the high pressure side and a shallow contact pressure gradient on the low pressure side. This ensures that the fluid film adhering to the cylinder bore is returned to the high pressure chamber on the return stroke of the piston minimizing the risk of leaks.

This also prevents the build-up of inter-seal pressure normally associated with tandem seal configurations. Inter-seal pressure depends on the system pressure, speed, stroke length and groove design.

ADVANTAGES

- Groove design with shallow radial depth
- Optimized leakage control and service life
- Low friction with small contact area between seal and counter surface
- Featuring the Turcon® Stepseal® 2K back pumping effect
- Utilize standard O-Ring installation groove
- Available in all diameter sizes from 10 to 2,700 mm

APPLICATION EXAMPLES

VL Seal® is recommended for hydraulics and general machine construction as an alternative to Stepseal® 2K and other single acting seals, for example in:

- Machine tools
- Automation
- Handling devices
- Single acting cylinders
- Automobile industry
- Servo hydraulics
- Down-hole tools
- O-Ring replacement

* Patent application: WO 02/08614 A2



OPERATING CONDITIONS

Pressure:	Up to 60 MPa
Speed:	Up to 15 m/s for Turcon® materials with linear movements frequency up to 5 Hz
Temperature:	-45 °C to +200 °C* depending on seal and O-Ring material
Media:	Mineral oil-based hydraulic fluids, flame retardant hydraulic fluids, environmentally friendly hydraulic fluids (bio-oils), phosphate ester, water and others, depending on the seal and O-Ring material compatibility see Table 127
Clearance:	The maximum permissible radial clearance S_{max} is shown in Table 128, as a function of the operating pressure and functional diameter.

IMPORTANT NOTE

The above data are maximum values and cannot be used at the same time, e.g. the maximum operating speed depends on material type, pressure, temperature and gap value. Temperature range also depends on media.

* In the case of unpressurized piston applications in temperatures below 0 °C please contact your local Customer Solution Center for more information!

RADIAL NOTCH

VL Seal® can be delivered with radial notches at the low pressure side. This is an advantage if the seal is used in rotary applications. Notches can prevent the seal from rotating in the groove by avoiding pressurised fluid being trapped between seal and groove corner.

INSTALLATION INSTRUCTIONS

VL Seal® is dimensionally interchangeable with seals for O-Ring housings, like Turcon® Double Delta® and Turcon® Variseal® M2. Groove dimensions, radial clearances and recommended seal series in relation to diameter are as illustrated in Table 128.

VL Seal® is preferably installed in closed grooves according to Figure 102 page 250. Depending on type and size installation in split grooves is also possible. Recommended minimum diameters for installation in closed grooves, see Table 81 page 250.

RECOMMENDED MATERIALS

The following material combinations have proven effective for hydraulic applications:

Turcon® VL Seal® in Turcon® M12

All round material for light to heavy hydraulic applications with linear, short stroke or helical movements in mineral oils, flame retardant hydraulic fluids, phosphate ester, bio-oils or fluids having less satisfactory lubricating properties:

O-Ring:	NBR 70 Shore A	N
	FKM 70 Shore A	V

Set code: M12N or M12V

Turcon® VL Seal® in Turcon® T46

For medium to heavy applications with linear movements in mineral oils and other media with good lubrication:

O-Ring:	NBR 70 Shore A	N
	FKM 70 Shore A	V

Set code: T46N or T46V

Zurcon® Z54 is recommended for VL Seal® as alternative to polyurethane U-Cups especially outside the size range of these products.

For specific applications, all Turcon® materials are available.

Other material combinations are listed in Table 127.

**Table 127: Turcon® and Zurcon® Materials for VL Seal®**

Material, Applications, Properties	Code	O-Ring Material Shore A	Code	O-Ring Operating Temp.* °C	Mating Surface Material	MPa max. Dynamic
Turcon® M12 First material choice for seals in linear motion Overall improved properties For new constructions and updating For all commonly applied hydraulic fluids including fluids with low lubrication performance Lowest friction and best sliding properties Lowest wear on seals Improved absorption of abrasive contaminants Low wear or abrasion of counter surface BAM tested Mineral fiber and Additives filled Color: Dark gray	M12	NBR 70	N	-30 to +100	Steel	50
		NBR 70 Low temp.	T	-45 to +80	Steel hardened Cast iron	
		FKM 70	V	-10 to +200	Stainless steel Titanium	
Turcon® T05 For lubricating fluids Also for gas service Very low friction Very good sliding and sealing properties Color: Turquoise	T05	NBR 70	N	-30 to +100	Steel	20
		NBR 70 Low temp.	T	-45 to +80	Steel hardened	
		FKM 70	V	-10 to +200		
Turcon® T08 For lubricating fluids and linear motion Very high compressive strength and extrusion resistance Hard counter surfaces is recommended Bronze filled Color: Light to dark brown, which may have variations in shading	T08	NBR 70	N	-30 to +100	Steel hardened	60
		NBR 70 Low temp.	T	-45 to +80	Cast iron	
		FKM 70	V	-10 to +200		
Turcon® T10 For hydraulic and pneumatic For linear motion in lubricating and non-lubricating fluids High extrusion resistance Good chemical resistance Not for electrically conducting fluids BAM tested Carbon, graphite filled Color: Black	T10	NBR 70	N	-30 to +100	Steel	40
		NBR 70 Low temp.	T	-45 to +80	Steel hardened Stainless steel	
		FKM 70	V	-10 to +200		
		EPDM 70	E**	-45 to +145		
Turcon® T29 For lubricating and non-lubricating fluids Good extrusion resistance Surface texture is not suitable for gas sealing Not for electrically conducting fluids Carbon fiber filled Color: Gray	T29	NBR 70	N	-30 to +100	Steel	30
		NBR 70 Low temp.	T	-45 to +80	Steel hardened Cast iron	
		FKM 70	V	-10 to +200	Stainless steel	
		EPDM 70	E**	-45 to +145		

Table continues on next page



Material, Applications, Properties	Code	O-Ring Material Shore A	Code	O-Ring Operating Temp.* °C	Mating Surface Material	MPa max. Dynamic
Turcon® T40 For lubricating and non-lubricating fluids High frequency and short strokes Water hydraulics Surface texture is not suitable for gas sealing Carbon fiber filled Color: Gray	T40	NBR 70	N	-30 to +100	Steel	25
		NBR 70 Low temp.	T	-45 to +80	Steel hardened Cast iron	
		FKM 70	V	-10 to +200	Stainless steel	
		EPDM 70	E**	-45 to +145	Aluminum	
Turcon® T46 For lubricated hydraulics in linear motion High compressive strength High extrusion resistance Very good sliding and wear properties BAM tested Bronze filled Color: Light to dark brown, which may have variations in shading	T46	NBR 70	N	-30 to +100	Steel hardened	50
		NBR 70 Low temp.	T	-45 to +80	Cast iron	
		FKM 70	V	-10 to +200		
Zurcon® Z53*** For mineral oil based fluids Very high abrasion and extrusion resistance For counter surface with rougher surface finish Limited chemical resistance Max. working temperature 110 °C Cast polyurethane Color: Yellow to light-brown	Z53	NBR 70	N	-30 to +100	Steel	60
		NBR 70 Low temp.	T	-45 to +80	Steel hardened Steel chrome plated (rod) Cast iron Stainless steel Ceramic coating	
Zurcon® Z54*** For mineral oil based fluids Linear and slowly turning movements High abrasion resistance For counter surface with rougher surface finish Good extrusion resistance Limited chemical resistance Max. working temperature 110 °C Cast polyurethane Color: Turquoise	Z54	NBR 70	N	-30 to +100	Steel	25
		NBR 70 Low temp.	T	-45 to +80	Steel hardened Steel chrome plated (rod) Cast iron Stainless steel Ceramic coating	
Zurcon® Z80 For lubricating and non-lubricating fluids Water based fluids, air and gases Dry air pneumatics High abrasion and extrusion resistance For service in abrasive conditions and media with particles Good chemical resistance Limited temperature capability (-60 to +80 °C) UHMWPE (Ultra High Molecular Weight Polyethylene) Color: White to off-white	Z80	NBR 70	N	-30 to (+100)	Steel	35
		NBR 70 Low temp.	T	-45 to +80	Steel hardened Stainless steel	
		EPDM 70	E**	-45 to (+145)	Aluminum Ceramic coating	

* The O-Ring Operation Temperature is only valid in mineral hydraulic oil (except EPDM).

** Material not suitable for mineral oils.

*** Max. diameter 2,300 mm.

BAM: Tested by "Bundesanstalt Materialprüfung, Germany".

□ Highlighted materials are recommended.



Installation Recommendation

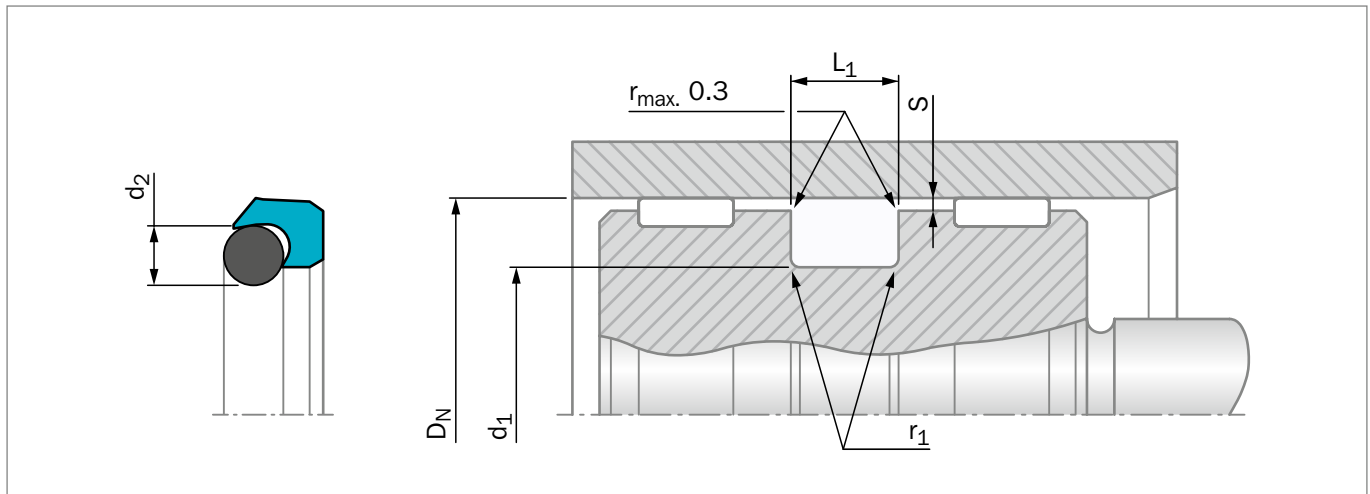

Figure 141: Installation Drawing

Table 128: Installation Dimensions - Standard Recommendations

Series No.	Bore Diameter D_N H9		Groove Diameter d_1 h9	Groove Width L_1 +0.2	Radius r_1 max	Radial Clearance S_{max}			O-Ring Cross Section d_2
	Standard Application	Available Range				10 MPa	20 MPa	30 MPa	
PEL10	14 - 24.9	10 - 100.0	$D_N - 4.5$	3.6	0.4	0.40	0.25	0.15	1.78
PEL20	25 - 45.9	16 - 200.0	$D_N - 6.2$	4.8	0.6	0.40	0.25	0.20	2.62
PEL30	46 - 124.9	28 - 400.0	$D_N - 9.4$	7.1	0.8	0.50	0.30	0.20	3.53
PEL40	125 - 399.9	45 - 650.0	$D_N - 12.2$	9.5	0.8	0.60	0.35	0.25	5.33
PEL50	400 - 649.9	125 - 999.9	$D_N - 15.9$	12.2	0.8	0.70	0.50	0.30	7.00
PEL60	650 - 999.9	400 - 999.9	$D_N - 19.0$	15.0	0.8	1.00	0.70	0.60	8.40
PEL6X	1,000 - 2,700		$D_N - 19.0$	15.0	0.8	1.00	0.70	0.60	8.40

* At pressures > 40 MPa use diameter tolerance H8/f8 (bore/piston) in the area behind seal or consult your local Customer Solution Center for alternative material or profiles.

Slydring® / Wear Rings are not applicable at very small radial clearances please consult the Slydring® section in this catalog.
For minimum diameter installation in closed grooves, see Table 81 page 250

ORDERING EXAMPLE

Turcon® VL Seal® complete with O-Ring, standard application:

Series: PEL30 from Table 128

Bore Diameter: $D_N = 80.0$ mm

TSS Part No.: PEL300800 from Table 129

Select the material from Table 127. The corresponding code numbers are appended to the TSS Part No. Together these form the TSS Article Number. The TSS Article Number for all intermediate sizes can be determined by following the example:

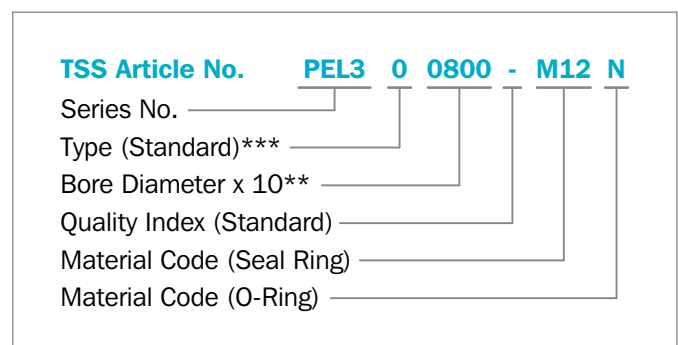

** For diameters $D_N \geq 1,000.0$ mm multiply only by factor 1.
Example: PEL6X for diameter $D_N = 1,200.0$ mm
TSS Article No.: PEL6X1200 - M12N

*** Use suffix "N" for seals with radial notches, for diameter $D_N < 1,000$ mm. (Radial notches for diameter $D_N \geq 1,000$ mm, special part number is required).



Table 129: Installation Dimensions / Part No.

Bore Dia.	Groove Dia.	Groove Width	TSS Part No.	O-Ring Dimensions	Bore Dia.	Groove Dia.	Groove Width	TSS Part No.	O-Ring Dimensions
D _N H9	d ₁ h9	L ₁ +0.2			D _N H9	d ₁ h9	L ₁ +0.2		
10.0	5.5	3.6	PEL100100	4.80 x 1.80	70.0	60.6	7.1	PEL300700	59.92 x 3.53
11.0	6.5	3.6	PEL100110	6.07 x 1.78	75.0	65.6	7.1	PEL300750	63.09 x 3.53
12.0	7.5	3.6	PEL100120	7.10 x 1.80	80.0	70.6	7.1	PEL300800	69.44 x 3.53
14.0	9.5	3.6	PEL100140	8.75 x 1.80	80.0	67.8	9.5	PEL400800	66.04 x 5.33
16.0	11.5	3.6	PEL100160	11.20 x 1.80	85.0	75.6	7.1	PEL300850	75.79 x 3.53
16.0	9.8	4.8	PEL200160	9.19 x 2.62	85.0	72.8	9.5	PEL400850	72.39 x 5.33
18.0	13.5	3.6	PEL100180	13.20 x 1.80	90.0	80.6	7.1	PEL300900	78.97 x 3.53
18.0	11.8	4.8	PEL200180	10.77 x 2.62	90.0	77.8	9.5	PEL400900	75.57 x 5.33
20.0	15.5	3.6	PEL100200	14.00 x 1.78	95.0	85.6	7.1	PEL300950	85.32 x 3.53
20.0	13.8	4.8	PEL200200	12.37 x 2.62	95.0	82.8	9.5	PEL400950	81.92 x 5.33
22.0	17.5	3.6	PEL100220	17.17 x 1.78	100.0	90.6	7.1	PEL301000	88.49 x 3.53
22.0	15.8	4.8	PEL200220	14.50 x 2.65	100.0	87.8	9.5	PEL401000	88.27 x 5.33
25.0	20.5	3.6	PEL100250	20.35 x 1.78	105.0	95.6	7.1	PEL301050	94.84 x 3.53
25.0	18.8	4.8	PEL200250	18.00 x 2.65	105.0	92.8	9.5	PEL401050	91.44 x 5.33
28.0	21.8	4.8	PEL200280	20.29 x 2.62	106.0	96.6	7.1	PEL301060	94.84 x 3.53
28.0	18.6	7.1	PEL300280	17.04 x 3.53	110.0	100.6	7.1	PEL301100	101.19 x 3.53
30.0	25.5	3.6	PEL100300	25.12 x 1.78	110.0	97.8	9.5	PEL401100	97.79 x 5.33
30.0	23.8	4.8	PEL200300	23.47 x 2.62	115.0	105.6	7.1	PEL301150	104.37 x 3.53
32.0	27.5	3.6	PEL100320	26.70 x 1.78	115.0	102.8	9.5	PEL401150	100.97 x 5.33
32.0	25.8	4.8	PEL200320	25.07 x 2.62	120.0	110.6	7.1	PEL301200	110.72 x 3.53
32.0	22.6	7.1	PEL300320	21.82 x 3.53	120.0	107.8	9.5	PEL401200	107.32 x 5.33
35.0	28.8	4.8	PEL200350	28.24 x 2.62	125.0	115.6	7.1	PEL301250	113.89 x 3.53
40.0	35.5	3.6	PEL100400	34.65 x 1.78	125.0	112.8	9.5	PEL401250	110.49 x 5.33
40.0	33.8	4.8	PEL200400	32.99 x 2.62	125.0	109.1	12.2	PEL501250	107.35 x 7.00
40.0	30.6	7.1	PEL300400	29.75 x 3.53	130.0	120.6	7.1	PEL301300	120.24 x 3.53
42.0	35.8	4.8	PEL200420	34.59 x 2.62	130.0	117.8	9.5	PEL401300	116.84 x 5.33
45.0	38.8	4.8	PEL200450	37.77 x 2.62	135.0	122.8	9.5	PEL401350	123.19 x 5.33
45.0	32.8	9.5	PEL400450	31.12 x 5.33	140.0	127.8	9.5	PEL401400	126.37 x 5.33
48.0	41.8	4.8	PEL200480	40.94 x 2.62	140.0	124.1	12.2	PEL501400	123.19 x 7.00
50.0	43.8	4.8	PEL200500	42.52 x 2.62	145.0	132.8	9.5	PEL401450	132.72 x 5.33
50.0	40.6	7.1	PEL300500	40.87 x 3.53	150.0	137.8	9.5	PEL401500	135.89 x 5.33
50.0	37.8	9.5	PEL400500	37.47 x 5.33	155.0	145.6	7.1	PEL301550	145.64 x 3.53
52.0	45.8	4.8	PEL200520	45.69 x 2.62	160.0	150.6	7.1	PEL301600	148.82 x 3.53
55.0	48.8	4.8	PEL200550	48.90 x 2.62	160.0	147.8	9.5	PEL401600	145.42 x 5.33
60.0	50.6	7.1	PEL300600	50.39 x 3.53	160.0	144.1	12.2	PEL501600	142.24 x 7.00
63.0	56.8	4.8	PEL200630	56.82 x 2.62	165.0	155.6	7.1	PEL301650	151.99 x 3.53
63.0	53.6	7.1	PEL300630	53.57 x 3.53	165.0	152.8	9.5	PEL401650	151.77 x 5.33
63.0	50.8	9.5	PEL400630	50.17 x 5.33	170.0	157.8	9.5	PEL401700	158.12 x 5.33
65.0	55.6	7.1	PEL300650	53.57 x 3.53	175.0	165.6	7.1	PEL301750	164.69 x 3.53
70.0	63.8	4.8	PEL200700	63.17 x 2.62	180.0	170.6	7.1	PEL301800	171.04 x 3.53



Bore Dia.	Groove Dia.	Groove Width	TSS Part No.	O-Ring Dimensions
D _N H9	d ₁ h9	L ₁ +0.2		
180.0	167.8	9.5	PEL401800	164.47 x 5.33
180.0	164.1	12.2	PEL501800	164.47 x 7.00
190.0	180.6	7.1	PEL301900	177.39 x 3.53
190.0	177.8	9.5	PEL401900	177.17 x 5.33
200.0	190.6	7.1	PEL302000	190.09 x 3.53
200.0	187.8	9.5	PEL402000	189.87 x 5.33
200.0	184.1	12.2	PEL502000	183.52 x 7.00
205.0	192.8	9.5	PEL402050	189.87 x 5.33
210.0	197.8	9.5	PEL402100	196.22 x 5.33
220.0	210.6	7.1	PEL302200	209.14 x 3.53
220.0	207.8	9.5	PEL402200	208.92 x 5.33
220.0	204.1	12.2	PEL502200	202.57 x 7.00
230.0	217.8	9.5	PEL402300	215.27 x 5.33
240.0	227.8	9.5	PEL402400	227.97 x 5.33
250.0	237.8	9.5	PEL402500	234.32 x 5.33
250.0	234.1	12.2	PEL502500	227.97 x 7.00
300.0	284.1	12.2	PEL503000	278.77 x 7.00
306.0	293.8	9.5	PEL403060	291.47 x 5.33
320.0	307.8	9.5	PEL403200	304.17 x 5.33
320.0	304.1	12.2	PEL503200	304.17 x 7.00
345.0	332.8	9.5	PEL403450	329.57 x 5.33
350.0	334.1	12.2	PEL503500	329.57 x 7.00
400.0	384.1	12.2	PEL504000	380.37 x 7.00
400.0	381.0	15.0	PEL604000	379.00 x 8.40
440.0	424.1	12.2	PEL504400	430.66 x 7.00
450.0	431.0	15.0	PEL604500	429.00 x 8.40
500.0	484.1	12.2	PEL505000	481.38 x 7.00
500.0	481.0	15.0	PEL605000	479.00 x 8.40
520.0	507.8	9.5	PEL405200	506.78 x 5.33
540.0	524.1	12.2	PEL505400	532.26 x 7.00
540.0	521.0	15.0	PEL605400	519.00 x 8.40
600.0	584.1	12.2	PEL506000	582.68 x 7.00
600.0	581.0	15.0	PEL606000	579.00 x 8.40
650.0	634.1	12.2	PEL506500	633.48 x 7.00
650.0	631.0	15.0	PEL606500	629.00 x 8.40
700.0	684.1	12.2	PEL507000	658.88 x 7.00
700.0	681.0	15.0	PEL607000	679.00 x 8.40
800.0	784.1	12.2	PEL508000	782.00 x 7.00
800.0	781.0	15.0	PEL608000	779.00 x 8.40
860.0	844.1	12.2	PEL508600	842.00 x 7.00

Bore Dia.	Groove Dia.	Groove Width	TSS Part No.	O-Ring Dimensions
D _N H9	d ₁ h9	L ₁ +0.2		
900.0	884.1	12.2	PEL509000	882.00 x 7.00
900.0	881.0	15.0	PEL609000	879.00 x 8.40
920.0	904.1	12.2	PEL509200	902.00 x 7.00
1,000.0	981.0	15.0	PEL6X1000	979.00 x 8.40
1,200.0	1,181.0	15.0	PEL6X1200	1,179.00 x 8.40
1,500.0	1,481.0	15.0	PEL6X1500	1,479.00 x 8.40
2,000.0	1,981.0	15.0	PEL6X2000	1,979.00 x 8.40
2,700.0	2,681.0	15.0	PEL6X2700	2,679.00 x 8.40

The bore diameters in **bold** type are in accordance with the recommendations of ISO 3320.

Other dimensions and all intermediate sizes up to 2,700 mm diameter including imperial (inch) sizes can be supplied.

ⓘ This page is intentionally left blank.

Zurcon® U-Cup PUA



Single-acting

Asymmetric, Single Lip

For O-Ring Grooves

Material:
Zurcon®



! This page is intentionally left blank.



■ Piston U-Cup PUA



■ Description

The U-Cup is a single-acting piston seal out of injection molded polyurethane. It is provided with a robust dynamic sealing lip and a wide contact area of the static lip, which guaranties an effective positioning in the groove.

The profile is suitable for pressures up to 40 MPa provided that the extrusion gap is adapted to the pressure level. Thanks to the elasticity of the polyurethane material the U-Cup can easily be installed in closed grooves.

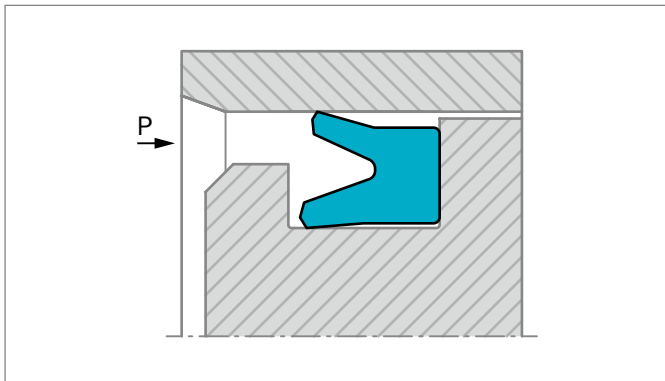

Figure 142: Piston U-Cup Type PUA

ADVANTAGES

- Simple groove design
- High abrasion resistance
- Long service life
- Effective sealing effect even with non excellent mating surface finish

APPLICATION EXAMPLES

The U-Cup is the recommended sealing element for single acting pistons of hydraulic components such as:

- Presses
- Lift platforms
- Aftermarket

OPERATING CONDITIONS

Pressure:	Up to 40 MPa
Speed:	Up to 0.5 m/s
Temperature:	from -35 °C to +110 °C
Media:	Mineral oil based hydraulic fluids
Clearance:	From Table 130 the maximum value of the radial clearance S_{max} can be selected for dimensioning the piston. The values indicated in this table must be reduced by 30% when temperature exceeds 80 °C.

Table 130: Clearance

Operating Pressure MPa	Radial Clearance S_{max}	
	$d_N < 60$ mm	$d_N > 60$ mm
5	0.40	0.50
10	0.30	0.40
20	0.20	0.30
30	0.15	0.20
40	0.10	0.15

IMPORTANT NOTE

The above data are maximum values and cannot be used at the same time, e.g. the maximum operating speed depends on material type, pressure, temperature and gap value. Temperature range also depends on media.

MATERIALS

Standard Material:

For hydraulic components in mineral oils or medium with good lubricating performance, polyurethane 93 Shore A

Zurcon® Z20

Color: Turquoise



■ Installation Recommendation

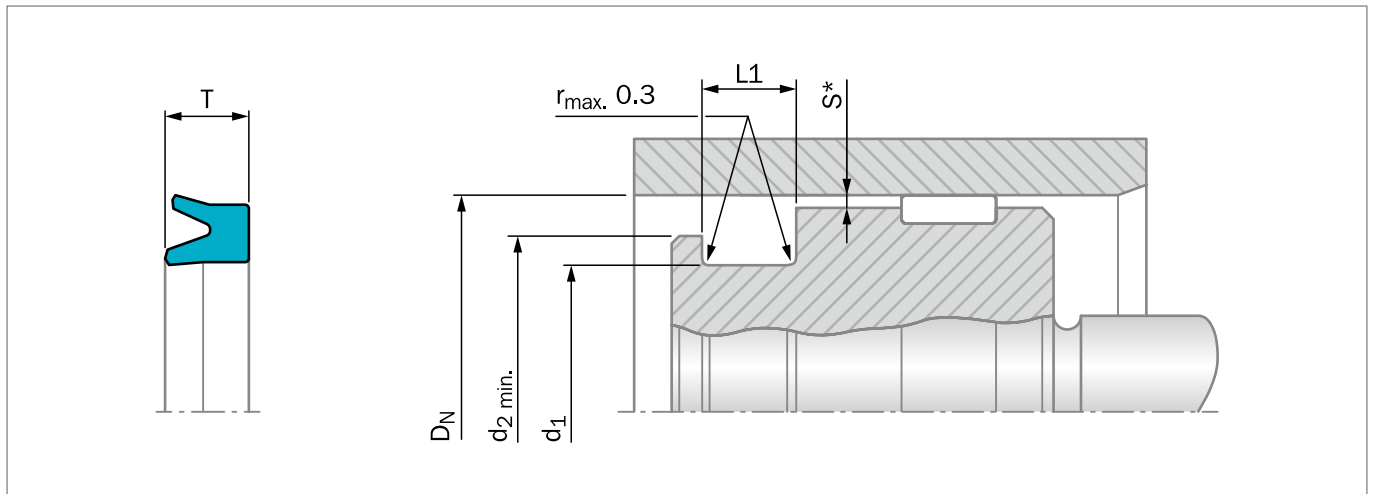

Figure 143: Installation Drawing

* Dimensions "S" see Table 130

ORDERING EXAMPLE

Bore Diameter:	$D_N = 80 \text{ mm}$
Groove Diameter:	$d_1 = 60 \text{ mm}$
Groove Width:	$L_1 = 13 \text{ mm}$
TSS Part No.:	PUA000800 from Table 131
Material Code:	Z20

TSS Article No.	PUA 0 00800 - Z20
TSS Series No.	PUA
Execution Code	0
Bore Diameter x 10	00800
Quality Index (Standard)	-
Material Code	Z20

**Table 131: Installation Dimensions / TSS Part No.**

Bore Diameter	Groove Diameter	Seal Width	Groove Width	Fitting Diameter	TSS Part No.
D_N	d_1	T	L1	d_2	
H9	h9		+0.2	min	
14.0	8.0	6.3	6.8	11.0	PUA000140
16.0	8.0	6.0	5.5	13.0	PUA300160
25.0	15.0	8.0	9.0	19.0	PUA000250
30.0	22.0	6.5	7.0	26.0	PUA400300
32.0	26.0	5.0	6.0	28.0	PUA200320
35.0	25.0	8.0	9.0	29.0	PUA100350
40.0	32.0	5.5	6.5	36.0	PUA300400
50.0	40.0	10.0	11.0	44.0	PUA400500
50.0	42.0	5.5	6.0	45.0	PUA900500
52.0	42.0	5.7	6.5	46.0	PUA000520
55.0	40.0	10.0	11.0	45.0	PUA000550
60.0	50.0	7.0	8.0	54.0	PUA000600
60.0	50.0	10.0	11.0	54.0	PUA600600
63.0	53.0	7.0	8.0	57.0	PUA200630
70.0	60.0	7.0	8.0	64.0	PUA100700
80.0	60.0	12.0	13.0	65.0	PUA000800
80.0	68.0	8.5	9.5	72.0	PUA300800
80.0	70.0	12.0	13.0	74.0	PUA700800
85.0	70.0	12.0	13.0	75.0	PUA300850
110.0	95.0	12.0	13.0	100.0	PUA101100
110.0	100.0	7.0	8.0	104.0	PUA201100
125.0	100.0	15.0	16.0	105.0	PUA201250
125.0	105.0	12.0	13.0	110.0	PUA301250
125.0	110.0	10.0	11.0	115.0	PUA101250
140.0	120.0	12.0	13.0	125.0	PUA001400
160.0	140.0	11.5	12.5	145.0	PUA001600
200.0	175.0	15.0	16.0	180.0	PUA102000

! This page is intentionally left blank.

Zurcon® Wynseal



Double-acting

Rubber-energized plastic-faced seal

High static and dynamic sealing effect

Material:

Zurcon® + NBR



! This page is intentionally left blank.



Zurcon® Wynseal



Description

The Zurcon® Wynseal is a double-acting seal consisting of a special polyurethane seal ring and an O-Ring as energizing element (Figure 144).

The particular characteristic of the seal is the special design of the seal edge profile. Two external seal edges act as primary seal for pressures from both sides and prevent any build-up of hydrodynamic pressure over the seal profile and the risk of the blow-by effect. The central back-up and sealing bulge increases the sealing effect*. Grooves are provided on both sides on the plane surfaces to provide activation of the energizing O-Ring. These ensure direct pressure loading of the seal under all operating conditions.

Since the installation groove is identical to that for the Turcon® Glyd Ring®, the seal is ideal for the standardisation of cylinder construction if, efficient and low cost seal elements are demanded in large quantities and, the cylinder can be adapted to meet different operating conditions. It has to be taken into consideration that in this case the gap dimension has to be checked!

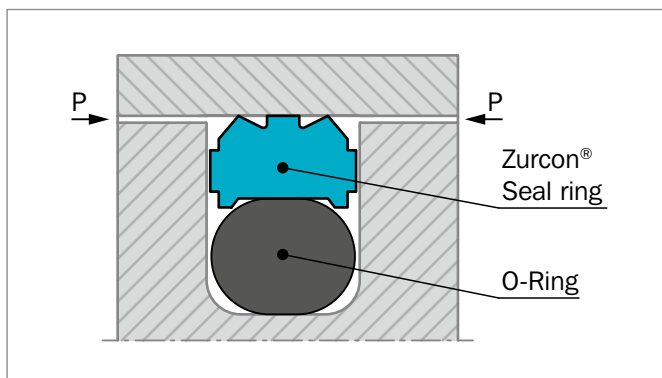

Figure 144: Zurcon® Wynseal

ADVANTAGES

- High static and dynamic sealing effect
- High abrasion resistance
- Simple groove design, one-piece piston possible
- Suitable for grooves to ISO 7425, Part 1.

* Only from PW42 and the following Series No.; PW40 and PW41 without sealing and supporting bulge.

APPLICATION EXAMPLES

The Zurcon® Wynseal is the recommended element for double acting pistons of hydraulic components in various sectors such as:

- Machine tools
- Forklifts and handling machinery
- Agriculture
- Industrial hydraulic light to medium duty

OPERATING CONDITIONS

Pressure:	Up to 25 MPa (Z20N)
Speed:	Up to 0.5 m/s
Temperature:	-35 °C to +110 °C
Media:	Mineral oil-based hydraulic fluids

IMPORTANT NOTE

The above data are maximum values and cannot be used at the same time, e.g. the maximum operating speed depends on material type, pressure, temperature and gap value. Temperature range also depends on media.

MATERIALS

Wynseal: Zurcon® Z20, 93 Shore A
 O-Ring: NBR 70 Shore A
 Set reference: Z20N



■ Installation Recommendation

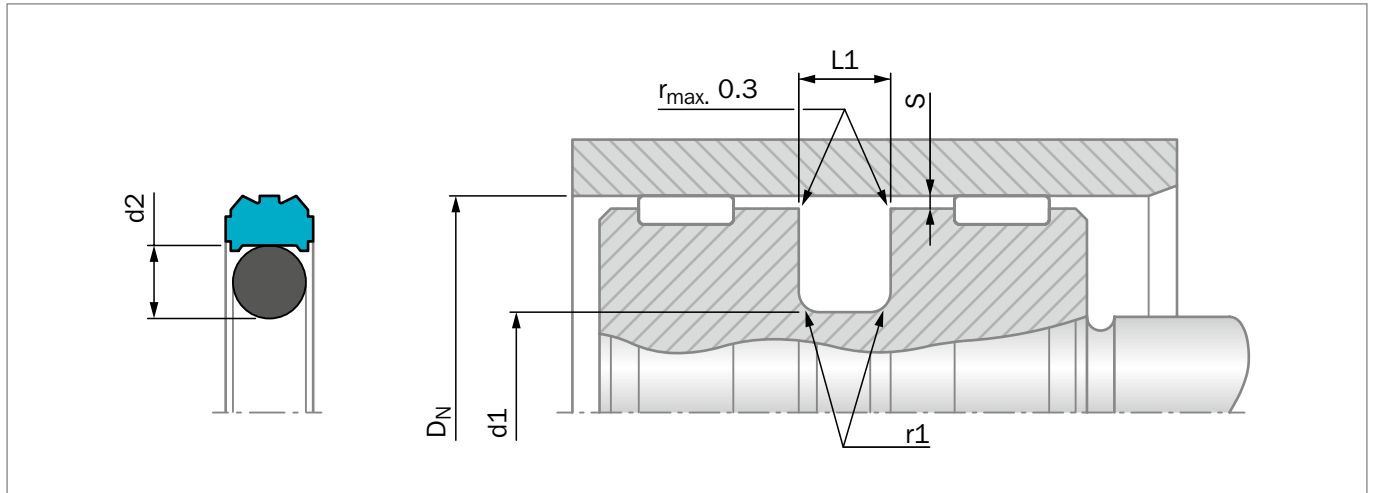

Figure 145: Installation Drawing

Table 132: Installation Dimensions

Series No.	Groove Diameter	Groove Width	Radius	Radial Clearance	O-Ring Cross Section
	d1 h9	L1 +0.2	r1	S _{max}	d2
PW40	DN - 4,9	2.2	0.4	0.20	1.78
PW41	DN - 7.5	3.2	0.6	0.25	2.62
PW42	DN - 11.0	4.2	1.0	0.25	3.53
PW43	DN - 15.5	6.3	1.3	0.30	5.33
PW44	DN - 21.0	8.1	1.8	0.30	7.00

ORDERING EXAMPLE

Wynseal for ISO groove

Bore Diameter:	D _N = 63 mm
Series No.:	PW43
TSS Part No.:	PW4300630 from Table 133
Material Code:	Z20
O-Ring Material Code:	N
Set Code:	Z20N

TSS Article No. **PW43** **0** **0630** - **Z20** **N**

TSS Series No. ————|

Type (Standard) ————|

Bore Diameter x 10 ————|

Quality Index (Standard) ————|

Material Code (Seal Ring) ————|

Material Code (O-Ring) ————|



Table 133: Installation Dimensions / TSS Part No.

Bore Diameter	Groove Diameter	Groove Width	TSS Part No.	Bore Diameter	Groove Diameter	Groove Width	TSS Part No.
D _N	d ₁	L ₁		D _N	d ₁	L ₁	
H9	h9	+0.2		H9	h9	+0.2	
12.0	7.1	2.2	PW4000120	95.0	79.5	6.3	PW4300950
12.0	4.5	3.2	PW4100120	100.0	84.5	6.3	PW4301000
16.0	8.5	3.2	PW4100160	105.0	89.5	6.3	PW4301050
20.0	12.5	3.2	PW4100200	110.0	94.5	6.3	PW4301100
22.0	14.5	3.2	PW4100220	115.0	99.5	6.3	PW4301150
24.0	16.5	3.2	PW4100240	120.0	104.5	6.3	PW4301200
25.0	17.5	3.2	PW4100250	125.0	109.5	6.3	PW4301250
25.0	14.0	4.2	PW4200250	125.0	104.0	8.1	PW4401250
30.0	22.5	3.2	PW4100300	130.0	114.5	6.3	PW4301300
32.0	24.5	3.2	PW4100320	135.0	114.0	8.1	PW4401350
32.0	21.0	4.2	PW4200320	140.0	119.0	8.1	PW4401400
35.0	27.5	3.2	PW4100350	150.0	129.0	8.1	PW4401500
35.0	24.0	4.2	PW4200350	160.0	139.0	8.1	PW4401600
36.0	28.5	3.2	PW4100360	170.0	149.0	8.1	PW4401700
38.0	30.5	3.2	PW4100380	180.0	159.0	8.1	PW4401800
40.0	32.5	3.2	PW4100400	190.0	169.0	8.1	PW4401900
40.0	29.0	4.2	PW4200400	200.0	179.0	8.1	PW4402000
45.0	34.0	4.2	PW4200450	210.0	189.0	8.1	PW4402100
45.0	29.5	6.3	PW4300450	220.0	199.0	8.1	PW4402200
50.0	39.0	4.2	PW4200500	230.0	209.0	8.1	PW4402300
50.0	34.5	6.3	PW4300500	250.0	229.0	8.1	PW4402500
52.0	36.5	6.3	PW4300520	300.0	279.0	8.1	PW4403000
55.0	44.0	4.2	PW4200550				
55.0	39.5	6.3	PW4300550				
56.0	45.0	4.2	PW4200560				
57.0	46.0	4.2	PW4200570				
60.0	49.0	4.2	PW4200600				
60.0	44.5	6.3	PW4300600				
63.0	52.0	4.2	PW4200630				
63.0	47.5	6.3	PW4300630				
65.0	54.0	4.2	PW4200650				
65.0	49.5	6.3	PW4300650				
70.0	59.0	4.2	PW4200700				
70.0	54.5	6.3	PW4300700				
75.0	64.0	4.2	PW4200750				
75.0	59.5	6.3	PW4300750				
80.0	69.0	4.2	PW4200800				
80.0	64.5	6.3	PW4300800				
85.0	69.5	6.3	PW4300850				
90.0	74.5	6.3	PW4300900				

The sizes printed in **bold** type are suitable for grooves to ISO 7425-1.
Additional dimensions can be delivered on request.

! This page is intentionally left blank.

Zurcon® Wynseal M



Double-acting

Rubber-energized plastic-faced seal

Material:

Turcon®, Zurcon® and Elastomer



! This page is intentionally left blank.



Zurcon® Wynseal M



Description

Zurcon® Wynseal M is a modified machined version, of the Zurcon® Wynseal design.

Wynseal M is a double-acting seal consisting of a Zurcon® or Turcon® seal ring and an O-Ring as energizing element – Figure 146.

The seal is designed with a seal edge profile. Two seal edges act as primary seal for pressures from both sides and prevent build-up of hydrodynamic pressure over the seal profile and the risk of blow-by effect. The central sealing and supporting rib increases the sealing effect*.

Radial notches are provided on both sides to provide activation of the energizing O-Ring. These ensure direct pressure loading of the seal under all operating conditions.

Installation groove is identical to that of Turcon® Glyd Ring®.

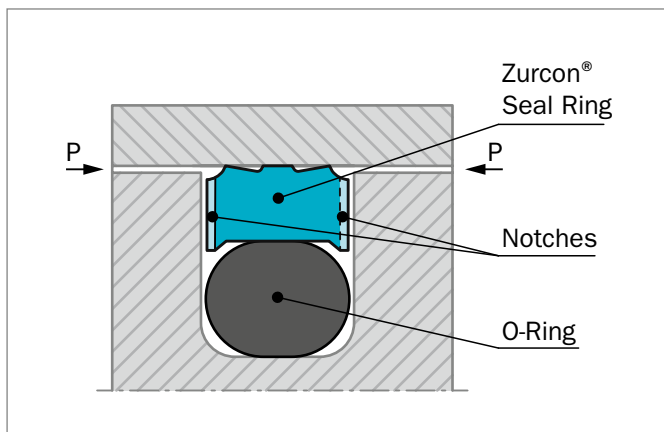

Figure 146: Zurcon® Wynseal M

* Only from PW62 and the following Series No.; PW60 is without seal edge profile and PW61 is without supporting rib.

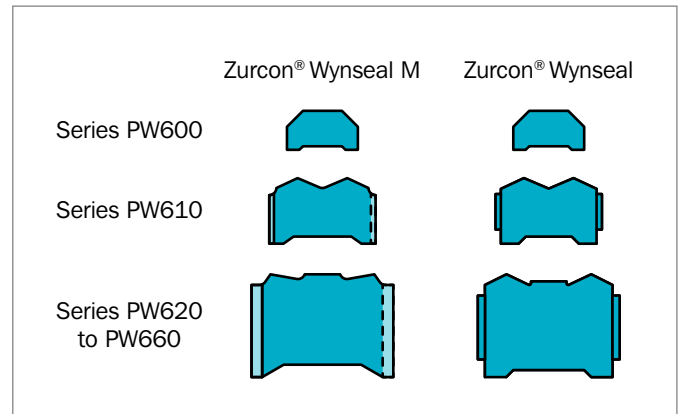

Figure 147: Zurcon® Wynseal M and Zurcon® Wynseal profiles

ADVANTAGES

- High static and dynamic sealing effect
- High abrasion resistance (Zurcon® materials)
- Simple groove design, one-piece piston possible
- Diameter range - from 8 to 2,700 mm
- Grooves according to ISO 7425-1
- Low friction
- Higher temperature (Turcon® materials)
- Higher pressure
- High chemical resistance

APPLICATION EXAMPLES

Zurcon® Wynseal M is used as double-acting piston seal for hydraulic components in applications such as:

- Machine tools
- Forklifts and handling machinery
- Agriculture
- Industrial hydraulics light to medium duty



OPERATING CONDITIONS

Pressure:	Up to 50 MPa
Speed:	Up to 10 m/s
Temperature:	-45 °C to +200 °C* depending on seal and O-Ring material
Media:	Mineral oil-based hydraulic fluids, flame retardant hydraulic fluids, environmentally friendly hydraulic fluids (bio-oils), phosphate ester, water and others, depending on temperature, seal and O-Ring material compatibility - see Table 134.
Clearance:	The maximum permissible radial clearance S_{max} is shown in Table 135, as a function of the operating pressure and functional diameter.

IMPORTANT NOTE

The above data are maximum values and cannot be used at the same time, e.g. the maximum operating speed depends on material type, pressure, temperature and gap value. Temperature range also depends on media.

* In the case of unpressurized piston applications in temperatures below 0 °C please contact your local Customer Solution Center for more information!

INSTALLATION INSTRUCTIONS

Wynseal® M is installed according to information on page 245 to page 249.

Closed groove installation according to dimensions in Table 80 page 249.

RECOMMENDED MATERIALS

The following material combinations have proven effective for hydraulic applications:

Wynseal M in Zurcon® Z54

For light to medium hydraulic applications with linear movements in mineral oils and other media with good lubrication:

O-Ring: NBR 70 Shore A N

Set code: Z54N

Wynseal M in Turcon® M12

All round material for light to heavy hydraulic applications linear, short stroke or helical movements in mineral oils, flame retardant hydraulic fluids, phosphate ester, bio-oils or fluids having low lubricating properties:

O-Ring: NBR 70 Shore A N
FKM 70 Shore A V

Set code: M12N or M12V

For specific applications, all Turcon® materials are available.

Other material combinations are listed in Table 134.

**Table 134: Turcon® and Zurcon® Materials for Wynseal M**

Material, Applications, Properties	Code	O-Ring Material Shore A	Code	O-Ring Operating Temp. * °C	Mating Surface Material	MPa max. Dynamic
Turcon® M12 First material choice for seals in linear motion Overall improved properties For new constructions and updating For all commonly applied hydraulic fluids including fluids with low lubrication performance Lowest friction and best sliding properties Lowest wear on seals Improved absorption of abrasive contaminants Low wear or abrasion of counter surface BAM tested Mineral fiber and Additives filled Color: Dark gray	M12	NBR 70	N	-30 to +100	Steel	35
		NBR 70 Low temp.	T	-45 to +80	Steel hardened Cast iron	
		FKM 70	V	-10 to +200	Stainless steel Titanium	
Turcon® T08 For lubricating fluids and linear motion Very high compressive strength and extrusion resistance Hard counter surfaces is recommended Bronze filled Color: Light to dark brown, which may have variations in shading	T08	NBR 70	N	-30 to +100	Steel hardened	50
		NBR 70 Low temp.	T	-45 to +80	Cast iron	
		FKM 70	V	-10 to +200		
Turcon® T40 For lubricating and non-lubricating fluids High frequency and short strokes Water hydraulics Surface texture is not suitable for gas sealing Carbon fiber filled Color: Gray	T40	NBR 70	N	-30 to +100	Steel	25
		NBR 70 Low temp.	T	-45 to +80	Steel hardened Cast iron	
		FKM 70	V	-10 to +200	Stainless steel Aluminum	
		EPDM 70	E**	-45 to +145		
Turcon® T46 For lubricated hydraulics in linear motion High compressive strength High extrusion resistance Very good sliding and wear properties BAM tested Bronze filled Color: Light to dark brown, which may have variations in shading	T46	NBR 70	N	-30 to +100	Steel hardened	35
		NBR 70 Low temp.	T	-45 to +80	Cast iron	
		FKM 70	V	-10 to +200		

Table continues on next page



Material, Applications, Properties	Code	O-Ring Material Shore A	Code	O-Ring Operating Temp.* °C	Mating Surface Material	MPa max. Dynamic
Zurcon® Z53*** For mineral oil based fluids Very high abrasion and extrusion resistance For counter surface with rougher surface finish Limited chemical resistance Max. working temperature 110 °C Cast polyurethane Color: Yellow to light-brown	Z53	NBR 70	N	-30 to +100	Steel	45
		NBR 70 Low temp.	T	-45 to +80	Steel hardened Cast iron Stainless steel Ceramic coating	
Zurcon® Z54*** For mineral oil based fluids Linear and slowly turning movements High abrasion resistance For counter surface with rougher surface finish Good extrusion resistance Limited chemical resistance Max. working temperature 110 °C Cast polyurethane Color: Turquoise	Z54	NBR 70	N	-30 to +100	Steel	25
		NBR 70 Low temp.	T	-45 to +80	Steel hardened Steel chrome plated (rod) Cast iron Stainless steel Ceramic coating	
Zurcon® Z80 For lubricating and non-lubricating fluids Water based fluids, air and gases Dry air pneumatics High abrasion and extrusion resistance For service in abrasive conditions and media with particles Good chemical resistance Limited temperature capability (-60 to +80 °C) UHMWPE (Ultra High Molecular Weight Polyethylene) Color: White to off-white	Z80	NBR 70	N	-30 to (+100)	Steel	30
		NBR 70 Low temp.	T	-45 to +80	Steel hardened Stainless steel	
		EPDM 70	E**	-45 to (+145)	Aluminum Bronze Ceramic coating	

* The O-Ring Operation Temperature is only valid in mineral hydraulic oil (except EPDM).

** Material not suitable for mineral oils.

*** Max. diameter 2,300 mm.

BAM: Tested by "Bundesanstalt Materialprüfung, Germany".

Highlighted materials are recommended.



Installation Recommendation

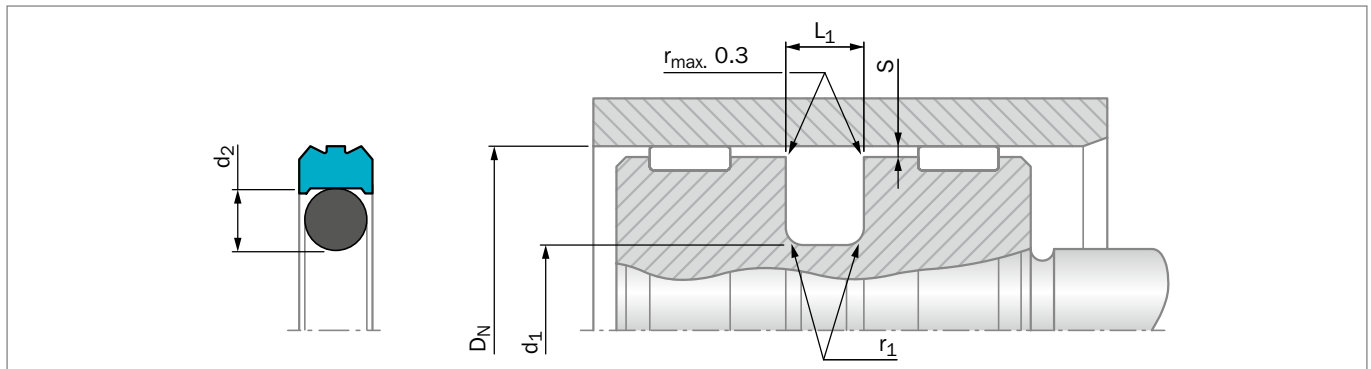

Figure 148: Installation Drawing

Table 135: Installation Dimensions – Standard Recommendations

Series No.	Bore Diameter D_N H9		Groove Diameter d_1 h9	Groove Width L_1 +0.2/-0	Radius r_1 max	Radial Clearance S_{max}^*			O-Ring Cross Section d_2
	Standard Application	Available Range				10 MPa	20 MPa	40 MPa	
PW600	8 - 14.9	8 - 140	$D_N - 4.9$	2.20	0.4	0.40	0.30	0.20	1.78
PW610	15 - 39.9	12 - 140	$D_N - 7.5$	3.20	0.6	0.60	0.50	0.30	2.62
PW620	40 - 79.9	15 - 320	$D_N - 11.0$	4.20	1.0	0.70	0.50	0.30	3.53
PW630	80 - 132.9	40 - 400	$D_N - 15.5$	6.30	1.3	0.80	0.60	0.40	5.33
PW640	133 - 329.9	80 - 700	$D_N - 21.0$	8.10	1.8	0.80	0.60	0.40	7.00
PW680	330 - 669.9	133 - 999.9	$D_N - 24.5$	8.10	1.8	0.90	0.70	0.50	7.00
PW650	670 - 999.9	330 - 999.9	$D_N - 28.0$	9.50	2.5	1.00	0.80	0.60	8.40
PW65X	1,000 - 1,200	-	$D_N - 28.0$	9.50	2.5	1.00	0.80	0.60	8.40
PW660**	-	670 - 999.9	$D_N - 38.0$	13.80	3.0	1.20	0.90	0.70	12.00
PW66X**	1,000 - 2,700***		$D_N - 38.0$	13.80	3.0	1.20	0.90	0.70	12.00

* At pressures > 40 MPa use diameter tolerance H8/f8 (bore/piston) in the area of the seal or consult your local Customer Solution Center for alternative material or profiles.

Slydring® / Wear Rings are not applicable at very small radial clearances please consult the Slydring® section in this catalog.

** O-Rings with 12 mm cross section are delivered as special profile ring.

*** Z53 and Z54 max diameter 2,300 mm.

ORDERING EXAMPLE

Zurcon® Wynseal M complete with O-Ring, standard application:

Series: PW630 from Table 135

Bore Diameter: $D_N = 80.0$ mm

TSS Part No.: PW6300800 from Table 136

Select the material from Table 134. The corresponding code numbers are appended to the TSS Part No. Together these form the TSS Article Number. The TSS Article Number for all intermediate sizes can be determined by following the example:

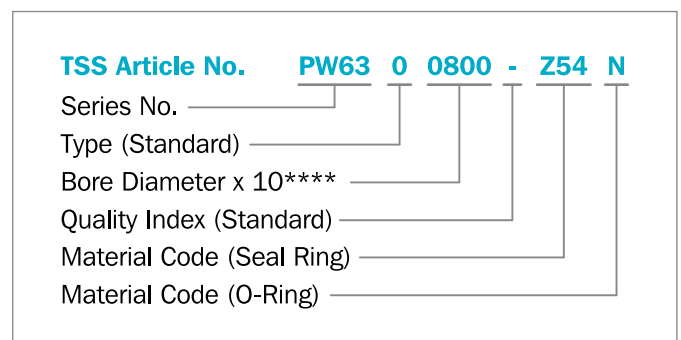

**** For diameters $D_N \geq 1,000.0$ mm multiply only by factor 1.
Example: PW66X for diameter $D_N = 1,200.0$ mm
TSS Article No.: PW66X1200 - Z54



Table 136: Installation Dimensions / TSS Part No.

Bore Dia.	Groove Dia.	Groove Width	TSS Part No.	O-Ring Dimensions	Bore Dia.	Groove Dia.	Groove Width	TSS Part No.	O-Ring Dimensions
D _N	d ₁	L ₁			D _N	d ₁	L ₁		
H9	h9	+0.2			H9	h9	+0.2		
8.0	3.1	2.2	PW6000080	2.90 x 1.78	70.0	59.0	4.2	PW6200700	56.74 x 3.53
10.0	5.1	2.2	PW6000100	4.80 x 1.80	70.0	54.5	6.3	PW6300700	53.34 x 5.33
12.0	7.1	2.2	PW6000120	6.70 x 1.80	75.0	64.0	4.2	PW6200750	63.09 x 3.53
14.0	9.1	2.2	PW6000140	8.75 x 1.80	75.0	59.5	6.3	PW6300750	56.52 x 3.53
15.0	7.5	3.2	PW6100150	7.59 x 2.62	80.0	69.0	4.2	PW6200800	66.27 x 3.53
16.0	11.1	2.2	PW6000160	10.82 x 1.78	80.0	64.5	6.3	PW6300800	62.87 x 5.33
16.0	8.5	3.2	PW6100160	7.59 x 2.62	80.0	59.0	8.1	PW6400800	58.00 x 7.00
18.0	13.1	2.2	PW6000180	12.42 x 1.78	85.0	69.5	6.3	PW6300850	69.22 x 5.33
18.0	10.5	3.2	PW6100180	9.19 x 2.62	85.0	64.0	8.1	PW6400850	63.00 x 7.00
20.0	15.1	2.2	PW6000200	14.00 x 1.78	90.0	79.0	4.2	PW6200900	78.97 x 3.53
20.0	12.5	3.2	PW6100200	12.37 x 2.62	90.0	74.5	6.3	PW6300900	72.39 x 5.33
22.0	17.1	2.2	PW6000220	17.17 x 1.78	90.0	69.0	8.1	PW6400900	68.00 x 7.00
22.0	14.5	3.2	PW6100220	13.94 x 2.62	95.0	84.0	4.2	PW6200950	82.14 x 3.53
24.0	16.5	3.2	PW6100240	15.54 x 2.62	95.0	79.5	6.3	PW6300950	78.74 x 5.33
25.0	20.1	2.2	PW6000250	18.77 x 1.78	95.0	74.0	8.1	PW6400950	73.00 x 7.00
25.0	17.5	3.2	PW6100250	17.12 x 2.62	100.0	89.0	4.2	PW6201000	88.49 x 3.53
25.0	14.0	4.2	PW6200250	13.87 x 3.53	100.0	84.5	6.3	PW6301000	81.92 x 5.33
28.0	20.5	3.2	PW6100280	20.29 x 2.62	100.0	79.0	8.1	PW6401000	78 x 7.00
30.0	22.5	3.2	PW6100300	21.89 x 2.62	105.0	94.0	4.2	PW6201050	91.67 x 3.53
32.0	27.1	2.2	PW6000320	26.70 x 1.78	105.0	89.5	6.3	PW6301050	88.27 x 5.33
32.0	24.5	3.2	PW6100320	23.47 x 2.62	110.0	99.0	4.2	PW6201100	98.02 x 3.53
32.0	21.0	4.2	PW6200320	20.22 x 3.53	110.0	94.5	6.3	PW6301100	91.44 x 5.33
35.0	27.5	3.2	PW6100350	26.64 x 2.62	110.0	89.0	8.1	PW6401100	88.00 x 7.00
35.0	24.0	4.2	PW6200350	23.40 x 3.53	115.0	99.5	6.3	PW6301150	97.79 x 5.33
36.0	28.5	3.2	PW6100360	28.24 x 2.62	120.0	109.0	4.2	PW6201200	107.54 x 3.53
38.0	30.5	3.2	PW6100380	29.82 x 2.62	120.0	104.5	6.3	PW6301200	100.97 x 5.33
40.0	32.5	3.2	PW6100400	31.42 x 2.62	120.0	99.0	8.1	PW6401200	98.00 x 7.00
40.0	29.0	4.2	PW6200400	28.17 x 3.53	125.0	114.0	4.2	PW6201250	113.89 x 3.53
42.0	31.0	4.2	PW6200420	29.75 x 3.53	125.0	109.5	6.3	PW6301250	107.32 x 5.33
45.0	34.0	4.2	PW6200450	32.92 x 3.53	125.0	104.0	8.1	PW6401250	103.00 x 7.00
48.0	37.0	4.2	PW6200480	36.09 x 3.53	130.0	114.5	6.3	PW6301300	113.67 x 5.33
50.0	42.5	3.2	PW6100500	40.94 x 2.62	130.0	109.0	8.1	PW6401300	108.00 x 7.00
50.0	39.0	4.2	PW6200500	37.70 x 3.53	135.0	114.0	8.1	PW6401350	113.67 x 7.00
50.0	34.5	6.3	PW6300500	32.69 x 5.33	140.0	124.5	6.3	PW6301400	123.19 x 5.33
52.0	41.0	4.2	PW6200520	40.87 x 3.53	140.0	119.0	8.1	PW6401400	116.84 x 7.00
55.0	44.0	4.2	PW6200550	44.04 x 3.53	150.0	134.5	6.3	PW6301500	132.72 x 5.33
56.0	45.0	4.2	PW6200560	44.04 x 3.53	150.0	129.0	8.1	PW6401500	126.37 x 7.00
60.0	49.0	4.2	PW6200600	47.22 x 3.53	160.0	144.5	6.3	PW6301600	142.24 x 5.33
63.0	52.0	4.2	PW6200630	50.39 x 3.53	160.0	139.0	8.1	PW6401600	135.89 x 7.00
63.0	47.5	6.3	PW6300630	46.99 x 5.33	170.0	149.0	8.1	PW6401700	145.42 x 7.00
65.0	54.0	4.2	PW6200650	53.57 x 3.53	180.0	164.5	6.3	PW6301800	164.47 x 5.33



Bore Dia.	Groove Dia.	Groove Width	TSS Part No.	O-Ring Dimensions
D _N	d ₁	L ₁		
H9	h9	+0.2		
180.0	159.0	8.1	PW6401800	158.12 x 7.00
190.0	169.0	8.1	PW6401900	164.47 x 7.00
200.0	184.5	6.3	PW6302000	183.52 x 5.33
200.0	179.0	8.1	PW6402000	177.17 x 7.00
210.0	189.0	8.1	PW6402100	183.52 x 7.00
220.0	199.0	8.1	PW6402200	196.22 x 7.00
230.0	214.5	6.3	PW6302300	208.92 x 5.33
230.0	209.0	8.1	PW6402300	208.92 x 7.00
240.0	219.0	8.1	PW6402400	215.27 x 7.00
250.0	229.0	8.1	PW6402500	227.97 x 7.00
250.0	225.5	8.1	PW6802500	215.27 x 7.00
250.0	134.5	6.3	PW6302500	234.32 x 5.33
260.0	239.0	8.1	PW6402600	240.67 x 7.00
270.0	249.0	8.1	PW6402700	240.67 x 7.00
280.0	259.0	8.1	PW6402800	253.37 x 7.00
290.0	269.0	8.1	PW6402900	266.07 x 7.00
300.0	279.0	8.1	PW6403000	278.77 x 7.00
300.0	275.5	8.1	PW6803000	266.07 x 7.00
320.0	299.0	8.1	PW6403200	291.47 x 7.00
320.0	295.5	8.1	PW6803200	291.47 x 7.00
350.0	325.5	8.1	PW6803500	316.87 x 7.00
360.0	335.5	8.1	PW6803600	329.57 x 7.00
380.0	355.5	8.1	PW6803800	354.97 x 7.00
400.0	375.5	8.1	PW6804000	367.67 x 7.00
450.0	425.5	8.1	PW6804500	417.96 x 7.00
500.0	475.5	8.1	PW6805000	468.76 x 7.00
600.0	575.5	8.1	PW6806000	557.66 x 7.00
700.0	672.0	9.5	PW6507000	670.00 x 8.40
780.0	752.0	9.5	PW6507800	750.00 x 8.40
800.0	772.0	9.5	PW6508000	770.00 x 8.40
900.0	872.0	9.5	PW6509000	870.00 x 8.40
1,000.0	972.0	9.5	PW65X1000	970.00 x 8.40
1,000.0	962.0	13.8	PW66X1000	960.00 x 12.00
1,200.0	1,172.0	9.5	PW65X1200	1,170.00 x 8.40
1,200.0	1,162.0	13.8	PW66X1200	1,160.00 x 12.00
1,500.0	1,462.0	13.8	PW66X1500	1,460.00 x 12.00
2,000.0	1,962.0	13.8	PW66X2000	1,960.00 x 12.00
2,700.0	2,662.0	13.8	PW66X2700	2,660.00 x 12.00

The bore diameters in **bold** type comply with the recommendations of ISO 3320. Other dimensions and all intermediate sizes up to 2,700 mm diameter including imperial (inch) sizes can be supplied.

All O-Rings with 12 mm cross section are delivered as special profile ring.

! This page is intentionally left blank.

POLYPAC® PHD/P



Double-acting

Heavy Duty, High Pressure

Excellent Leakage Control

Material:

Zurcon® , NBR Elastomer + POM



! This page is intentionally left blank.



■ PHD/P Seal

■ Description



The PHD/P Seal is a high-pressure heavy-duty piston seal with excellent leakage control and superior extrusion and wear resistance

The PHD/P seal is a combination of a Zurcon® polyurethane slipper seal energised by an elastomer profile ring and completed with two Back-up rings (POM). It is manufactured with a predefined interference fit, which together with the squeeze of the elastomer part ensures a good sealing effect even at low system pressure. At higher pressures the elastomer part is energised by the system pressure and consequently activates the slipper seal in the radial direction.

The Back-up rings prevent the slipper seal from extrusion and ensure a long service life even under harsh conditions.

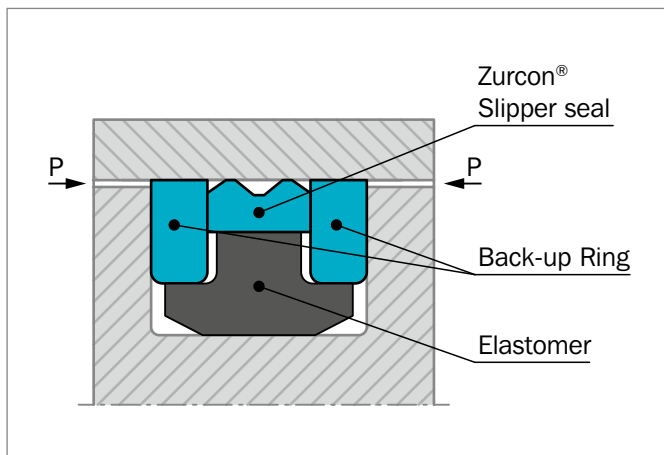

Figure 149: PHD/P Seal

ADVANTAGES

- Simple groove design
- Excellent sealing effect
- Excellent wear resistance
- Increased clearance possible
- Long service life

APPLICATION EXAMPLES

The PHD/P Seal is the recommended sealing element for double acting pistons of hydraulic cylinders working in very harsh conditions such as:

- Excavators
- Heavy duty cylinders

OPERATING CONDITIONS

Pressure:	Up to 35 MPa
Speed:	Up to 0.5 m/s
Temperature:	-35 °C to +110 °C
Media:	Mineral oil-based hydraulic fluids

IMPORTANT NOTE

The above data are maximum values and cannot be used at the same time, e.g. the maximum operating speed depends on material type, pressure, temperature and gap value. Temperature range also depends on media.

MATERIALS

Standard Application

For hydraulic components in mineral oils or medium with good lubricating performance.

Slipper Seal: Zurcon® Z20 93 Shore A

Energiser: NBR 80 Shore A

Back-up rings: POM

Material code for the set: Z2053



■ Installation Recommendation

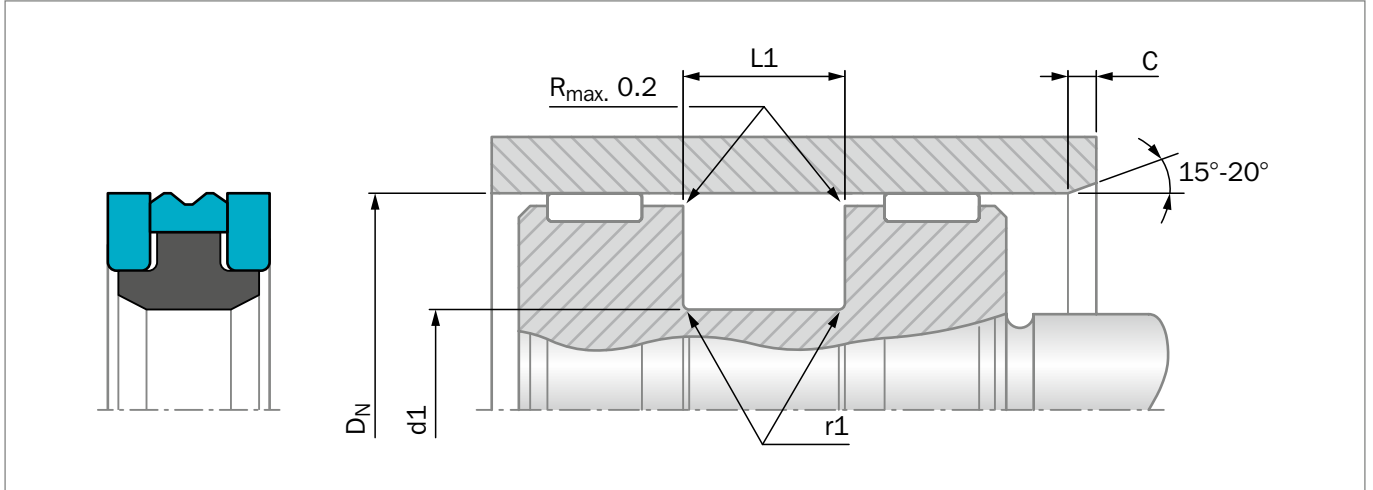

Figure 150: Installation Drawing

ORDERING EXAMPLE

PHD/P Seal, complete.

Bore Diameter:	$D_N = 80.0 \text{ mm}$
TSS Part No.:	PKPOP0800
Material Set-Code:	Z2053
Polypac Ref. No.:	PHD 8065P

TSS Article No.	PKPO P 0800 - Z2053
TSS Series No.	PKPO
Type (Standard)	P
Bore Diameter x 10	0800
Quality Index (Standard)	Z2053
Material Set-Code	Z2053

Table 137: Installation Dimensions / TSS Part No.

Bore Diameter	Groove Diameter	Groove Width	Inlet Chamfer	Radius	TSS Article No.	Polypac Ref. No.
D_N	$d1$	$L1$	C	$r1$		
H9	h9	+0.2				
50.0	36.0	9.0	5.0	0.3	PKPOP0500-Z2053	PHD 5036P-Z20
55.0	41.0	9.0	5.0	0.3	PKPOP0550-Z2053	PHD 5541P-Z20
60.0	46.0	9.0	5.0	0.3	PKPOP0600-Z2053	PHD 6046P-Z20
63.0	48.0	11.0	5.0	0.5	PKPOP0630-Z2053	PHD 6348P-Z20
65.0	50.0	11.0	5.0	0.5	PKPOP0650-Z2053	PHD 6550P-Z20
70.0	55.0	11.0	5.0	0.5	PKPOP0700-Z2053	PHD 7055P-Z20
75.0	60.0	11.0	5.0	0.5	PKPOP0750-Z2053	PHD 7560P-Z20
80.0	65.0	11.0	5.0	0.5	PKPOP0800-Z2053	PHD 8065P-Z20
85.0	70.0	11.0	5.0	0.5	PKPOP0850-Z2053	PHD 8570P-Z20
90.0	75.0	11.0	5.0	0.5	PKPOP0900-Z2053	PHD 9075P-Z20
95.0	80.0	11.0	5.0	0.5	PKPOP0950-Z2053	PHD 9580P-Z20
100.0	85.0	12.5	5.0	0.5	PKPOP1000-Z2053	PHD 10085P-Z20



Bore Diameter	Groove Diameter	Groove Width	Inlet Chamfer	Radius	TSS Article No.	Polypac Ref. No.
D_N	d_1	L_1	C	r_1		
H9	h9	+0.2				
105.0	90.0	12.5	5.0	0.5	PKPOP1050-Z2053	PHD 10590P-Z20
110.0	95.0	12.5	5.0	0.5	PKPOP1100-Z2053	PHD 11095P-Z20
115.0	100.0	12.5	5.0	0.5	PKPOP1150-Z2053	PHD 115100P-Z20
120.0	105.0	12.5	5.0	0.5	PKPOP1200-Z2053	PHD 120105P-Z20
125.0	102.0	16.0	6.5	0.6	PKPOP1250-Z2053	PHD 125102P-Z20
130.0	107.0	16.0	6.5	0.6	PKPOP1300-Z2053	PHD 130107P-Z20
135.0	112.0	16.0	6.5	0.6	PKPOP1350-Z2053	PHD 135112P-Z20
140.0	117.0	16.0	6.5	0.6	PKPOP1400-Z2053	PHD 140117P-Z20
145.0	122.0	16.0	6.5	0.6	PKPOP1450-Z2053	PHD 145122P-Z20
150.0	127.0	16.0	6.5	0.6	PKPOP1500-Z2053	PHD 150127P-Z20
155.0	132.0	16.0	6.5	0.6	PKPOP1550-Z2053	PHD 155132P-Z20
160.0	137.0	16.0	6.5	0.6	PKPOP1600-Z2053	PHD 160137P-Z20
165.0	142.0	16.0	6.5	0.6	PKPOP1650-Z2053	PHD 165142P-Z20
170.0	147.0	16.0	6.5	0.6	PKPOP1700-Z2053	PHD 170147P-Z20
180.0	157.0	16.0	6.5	0.6	PKPOP1800-Z2053	PHD 180157P-Z20

Radial Clearance: For pressure up to 35 MPa 0.50

! This page is intentionally left blank.

Compact Seal POLYPAC® - Duopac DPS/DPC



Double-acting

Combined seal and guide element

Material:

Fabric reinforced NBR and POM



! This page is intentionally left blank.



DUOPAC rubber fabric reinforced compact seals Type DPS and DPC



Description

The compact seals DUOPAC DPS and DPC types are double acting piston seals with integrated guide rings. DUOPAC has been designed to optimize the advantages of the materials selection:

- Fabric reinforcement with high mechanical strength, optimum thermal stability and lubricating properties is incorporated in the sealing element all over the dynamic contact area. For the DUOPAC DPC the reinforcement is extended on both sides to improve the extrusion resistance
- Nitrile based elastomer with optimum elasticity and low compression set provides the initial radial pre-load
- Acetal resin with improved form stability gives the Guide/backup rings high distortion and extrusion resistance

TYPE DPS

The DPS profile has been designed for its installation in closed grooves. The radial dimension of the profile has been reduced to the minimum to allow the necessary deformation during installation in closed grooves.

Consequently its use must be limited to pressures up to 35 MPa.

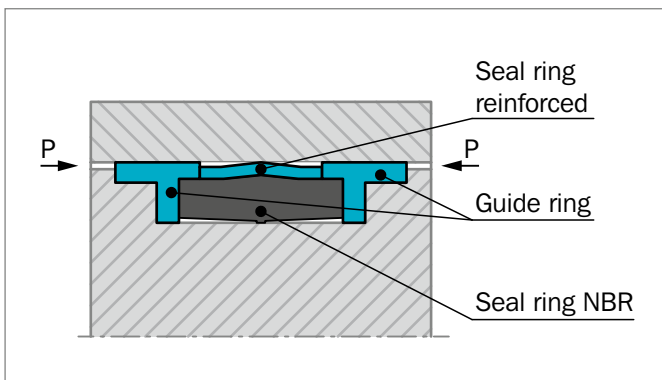

Figure 151: Compact Seal, Type DPS

TYPE DPC

The DPC profile is much more robust and can therefore be used for pressure level up to 70 MPa.

An open groove is necessary.

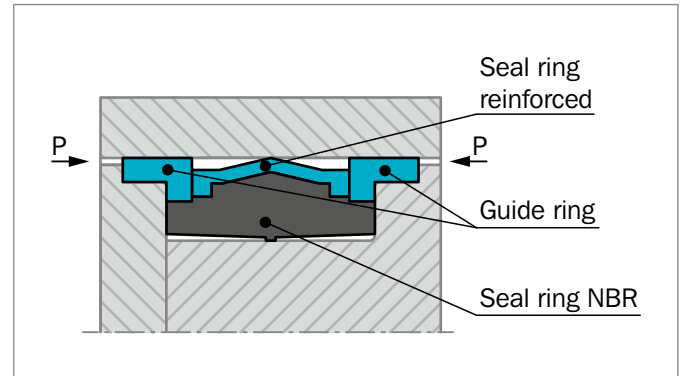

Figure 152: Compact Seal, Type DPC

ADVANTAGES

- DPS can be installed into closed grooves but its use must consequently be limited to medium duty applications
- DPC are usually installed in open grooves in Heavy Duty applications (pressure peak up to 80 MPa)
- Improved abrasion resistance
- Excellent sealing effect in combination with good dynamic and static friction behavior

APPLICATION EXAMPLES

The Compact seals are the recommended Sealing element for double acting Pistons of hydraulic components in following applications:

- Mining cylinders
- Presses
- Steel mills equipment
- Water hydraulic cylinders



OPERATING CONDITIONS

For an optimum performance of the DUOPAC, the recommended tolerances and surface finish must be applied.

Pressure:	Up to 35 MPa DPS type Up to 70 MPa DPC type
Speed:	Up to 0.5 m/s
Temperature:	-30 °C to +130 °C
Media:	Mineral oil based hydraulic fluids, water/oil and water/glycol emulsions.

IMPORTANT NOTE

The above data are maximum values and cannot be used at the same time, e.g. the maximum operating speed depends on material type, pressure, temperature and gap value. Temperature range also depends on media.

MATERIALS

- The compact seals DUOPAC are available in the following material composition:

Sealing element: Rubber fabric reinforced NBR

Guide/Back-up Rings: POM

Material set-code: NOOOC



■ Installation Recommendation, Type DPS

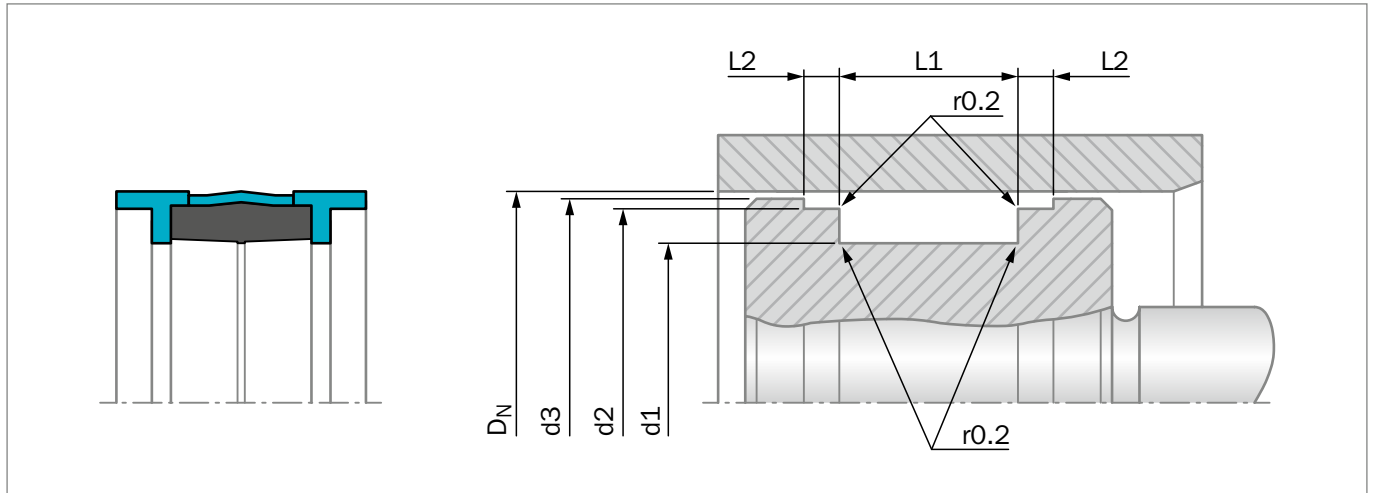

Figure 153: Installation Drawing

ORDERING EXAMPLE

Compact Seal Type DPS

Bore Diameter:	$D_N = 80 \text{ mm}$
Groove Diameter:	$d1 = 66 \text{ mm}$
Groove Width:	$L1 = 22.5 \text{ mm}$
TSS Part No.:	PCE100800 from Table 138
Material Set-Code:	N000C

TSS Article No. **PCE1 0 0800 - N000C**

TSS Series No. ——— PCE1
 Type (Standard) ——— 0
 Bore Diameter x 10 ——— 0800
 Quality Index (Standard) ———
 Material Set-Code ——— N000C
 Polypac Ref. No.: DPS 8066

Table 138: Installation Dimensions / TSS Article No.

Bore Diameter	Groove Dimensions					TSS Article No.	Description
	D_N	d1	L1	L2	d2		
H11	h9	+0.2	+0.1	h9	h11		
25.0	17.0	10.0	4.0	22.0	24.0	PCE000250-N000C	DPS 2517/1
32.0	24.0	15.5	3.2	28.0	31.4	PCE000320-N000C	DPS 3224
32.0	24.0	10.0	4.0	29.0	31.0	PCE100320-N000C	DPS 3224/1
35.0	27.0	15.5	3.2	31.0	34.4	PCE000350-N000C	DPS 3527
40.0	32.0	15.5	3.2	36.0	39.4	PCE000400-N000C	DPS 4032
40.0	32.0	10.0	4.0	37.0	39.0	PCE100400-N000C	DPS 4032/1
45.0	37.0	15.5	3.2	41.0	44.4	PCE000450-N000C	DPS 4537
50.0	38.0	20.5	4.2	46.0	49.4	PCE000500-N000C	DPS 5038
50.0	40.0	12.5	4.0	47.0	49.0	PCE100500-N000C	DPS 5040/1
55.0	43.0	20.5	4.2	51.0	54.4	PCE000550-N000C	DPS 5543
60.0	48.0	20.5	4.2	56.0	59.4	PCE000600-N000C	DPS 6048
63.0	51.0	20.5	4.2	59.0	62.4	PCE000630-N000C	DPS 6351



Bore Diameter	Groove Dimensions					TSS Article No.	Description
	D _N	d1	L1	L2	d2		
H11	h9	+0.2	+0.1	h9	h11		
63.0	53.0	12.5	4.0	60.0	62.0	PCE100630-N000C	DPS 6353/1
65.0	53.0	20.5	4.2	61.0	64.4	PCE000650-N000C	DPS 6553
70.0	58.0	20.5	4.2	66.0	69.4	PCE000700-N000C	DPS 7058
75.0	63.0	20.5	4.2	71.0	74.4	PCE000750-N000C	DPS 7563
80.0	65.0	20.0	5.0	76.0	78.5	PCE000800-N000C	DPS 8065/1
80.0	66.0	22.5	5.2	76.0	79.4	PCE100800-N000C	DPS 8066
85.0	71.0	22.5	5.2	81.0	84.4	PCE000850-N000C	DPS 8571
90.0	76.0	22.5	5.2	86.0	89.4	PCE000900-N000C	DPS 9076
100.0	85.0	20.0	5.0	96.0	98.5	PCE001000-N000C	DPS 10085/1
100.0	86.0	22.5	5.2	96.0	99.4	PCE101000-N000C	DPS 10086
110.0	96.0	22.5	5.2	106.0	109.4	PCE001100-N000C	DPS 11096
120.0	106.0	22.5	5.2	116.0	119.4	PCE001200-N000C	DPS 120106
125.0	105.0	25.0	6.3	120.0	123.0	PCE001250-N000C	DPS 125105/1
125.0	108.0	26.5	7.2	121.0	124.4	PCE101250-N000C	DPS 125108
140.0	120.0	25.0	6.3	135.0	138.0	PCE001400-N000C	DPS 140120/1
140.0	123.0	26.5	7.2	136.0	139.4	PCE101400-N000C	DPS 140123
150.0	133.0	26.5	7.2	146.0	149.4	PCE001500-N000C	DPS 150133
160.0	140.0	25.0	6.3	155.0	158.0	PCE001600-N000C	DPS 160140/1
160.0	143.0	26.5	7.2	156.0	159.4	PCE101600-N000C	DPS 160143
180.0	163.0	26.5	7.2	176.0	179.4	PCE001800-N000C	DPS 180163
200.0	170.0	36.0	12.5	192.0	197.0	PCE002000-N000C	DPS 200170/1
200.0	180.0	31.5	9.2	196.0	199.4	PCE102000-N000C	DPS 200180
220.0	200.0	31.5	9.2	216.0	219.4	PCE002200-N000C	DPS 220200
250.0	230.0	31.5	9.2	246.0	249.4	PCE002500-N000C	DPS 250230

The bore diameters in **bold** type comply with the recommendations of ISO 6547.



■ Installation Recommendation, Type DPC

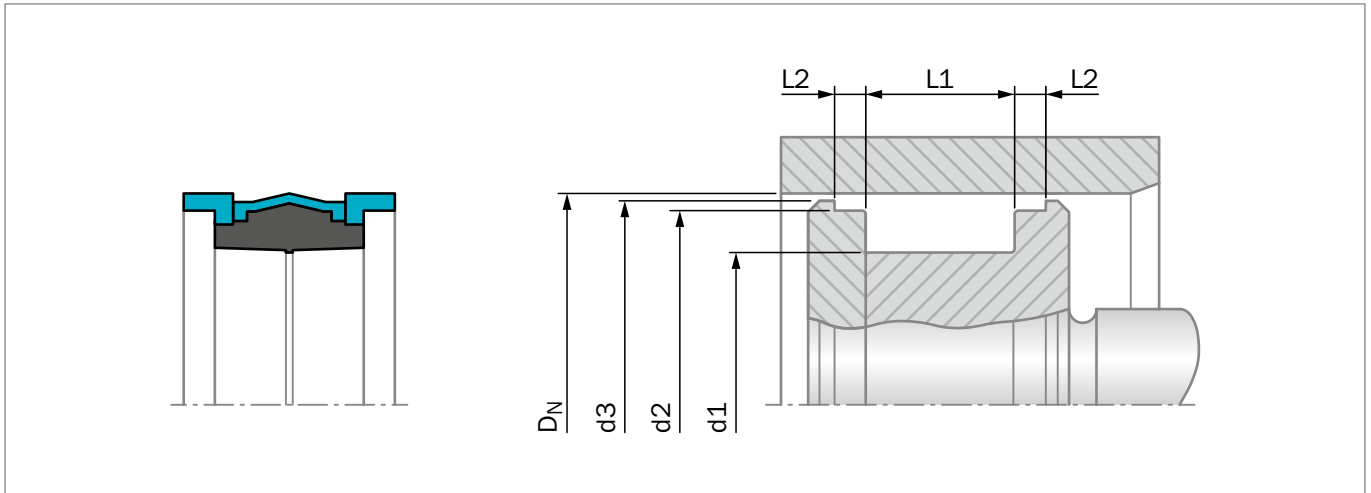

Figure 154: Installation Drawing

ORDERING EXAMPLE

Compact Seal Type DPC

Bore Diameter:	$D_N = 80 \text{ mm}$
Groove Diameter:	$d1 = 60 \text{ mm}$
Groove Width:	$L1 = 22.4 \text{ mm}$
TSS Part No.:	PCF000800 from Table 139
Material Set-Code:	N000C

TSS Article No. **PCF0 0 0800 - N000C**

TSS Series No. ———— PCF0 0 0800 ———— N000C
 Type (Standard) ———— 0 ————
 Bore Diameter x 10 ———— 0800 ————
 Quality Index (Standard) ———— N000C ————
 Material Set-Code ————
 Polypac Ref. No.: DPC 8060

Table 139: Installation Dimensions / TSS Article No.

Bore Diameter	Groove Dimensions					TSS Article No.	Description
	D_N	$d1$	L1	L2	$d2$		
H11	h9	+0.2	+0.1	h11	h11		
30.0	17.0	15.4	6.35	26.50	29.00	PCF000300-N000C	DPC 3017
35.0	22.0	15.4	6.35	31.40	33.70	PCF000350-N000C	DPC 3522
40.0	24.0	18.4	6.35	35.40	38.70	PCF000400-N000C	DPC 4024
45.0	29.0	18.4	6.35	40.40	43.70	PCF000450-N000C	DPC 4529
50.0	34.0	18.4	6.35	45.40	48.70	PCF000500-N000C	DPC 5034
55.0	39.0	18.4	6.35	50.40	53.70	PCF000550-N000C	DPC 5539
60.0	44.0	18.4	6.35	55.40	58.70	PCF000600-N000C	DPC 6044
65.0	50.0	18.4	6.35	60.40	63.70	PCF000650-N000C	DPC 6550
70.0	50.0	22.4	6.35	64.20	68.30	PCF000700-N000C	DPC 7050
75.0	55.0	22.4	6.35	69.20	73.30	PCF000750-N000C	DPC 7555
80.0	60.0	22.4	6.35	74.20	78.30	PCF000800-N000C	DPC 8060
85.0	65.0	22.4	6.35	79.20	83.30	PCF000850-N000C	DPC 8565



Bore Diameter	Groove Dimensions					TSS Article No.	Description
	D _N	d1	L1	L2	d2		
H11	h9	+0.2	+0.1	h11	h11		
90.0	70.0	22.4	6.35	84.15	88.30	PCF000900-N000C	DPC 9070
95.0	75.0	22.4	6.35	89.15	93.30	PCF000950-N000C	DPC 9575
100.0	75.0	22.4	6.35	93.15	98.05	PCF001000-N000C	DPC 10075
100.0	80.0	25.4	6.35	94.15	98.30	PCF101000-N000C	DPC 10080
105.0	85.0	22.4	6.35	98.10	103.00	PCF001050-N000C	DPC 10585
110.0	85.0	22.4	6.35	103.10	108.00	PCF001100-N000C	DPC 11085
120.0	100.0	25.4	6.35	114.10	118.00	PCF001200-N000C	DPC 120100
130.0	105.0	25.4	6.35	123.10	128.00	PCF001300-N000C	DPC 130105
140.0	115.0	25.4	6.35	133.00	138.00	PCF001400-N000C	DPC 140115
150.0	125.0	25.4	6.35	143.00	148.00	PCF001500-N000C	DPC 150125
160.0	135.0	33.0	6.35	153.00	158.00	PCF001600-N000C	DPC 160135

POLYPAC® Veepac CH



Single-acting

Set of Chevron Ring

With Support and Pressure Energizing Ring

Without and with Anti-extrusion Ring

Material:

Fabric Reinforced Rubber -
POM or PTFE



! This page is intentionally left blank.



■ Veepac CH



■ Description

Veepac seals are sets of fabric reinforced chevron rings. They are composed by a support ring, "V" shaped sealing rings and a pressure energizing ring.

The support ring or base ring guides and sustains the other "V" shaped rings for best performance. Special versions provide incorporated anti-extrusion rings, either on the inner or outer side, for rod or piston applications (see type CH/NEI or CH/NEO). In standard version the support ring is manufactured in cotton fabric reinforced rubber, for a good anti-extrusion resistance.

The intermediate "V" shaped rings (vee-rings) are the real sealing elements of Veepac seals. Their particular shape confers the capacity of increasing sealing effectiveness under high pressure. In standard version they are made in cotton fabric reinforced NBR and pure NBR.

The energizer ring ensures uniform loading of pressure on the other rings. This element is manufactured in acetal resin, or cotton fabric reinforced nitrile for diameters over 300 mm (standard material).

DESIGN

The veepac seals are available in different compositions. The standard version consists in a support ring, two fabric reinforced vee-rings, one rubber vee-ring and the energizing ring.

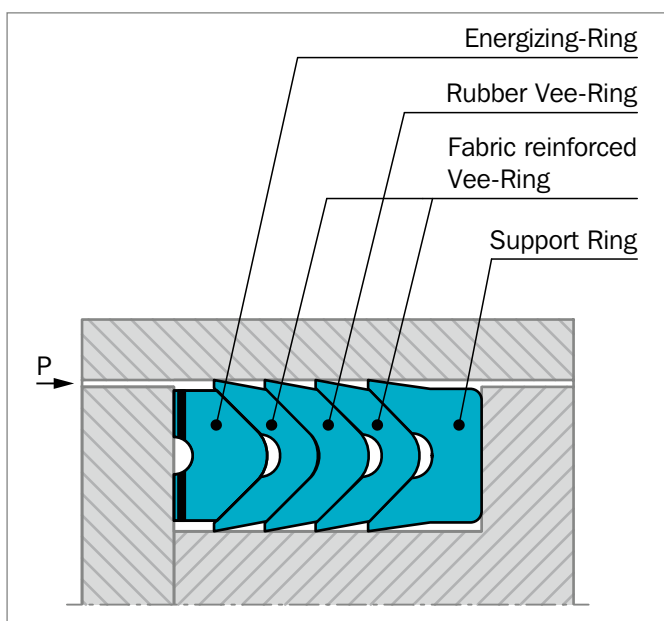

Figure 155: Veepac standard design

When the rubber vee-ring isn't available (indicated in the Table 142 with the symbol ^) the veepac are assembled with three fabric reinforced vee-ring as shown in figure below.

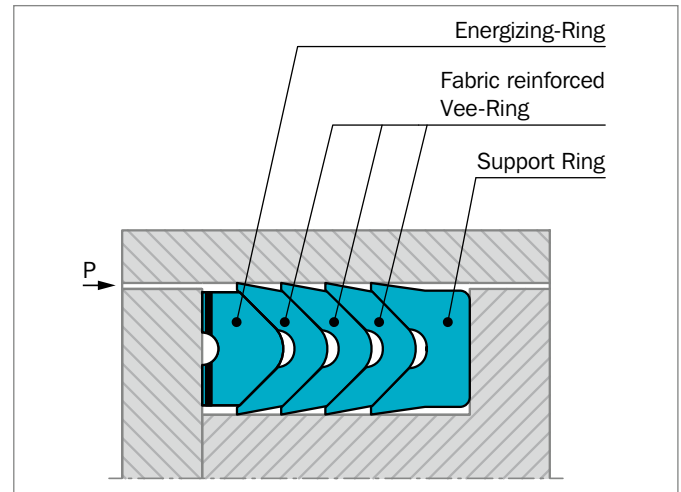

Figure 156: Veepac design with 3 fabric reinforced vee-ring

Where extrusion gaps are greater than those specified or for higher pressure conditions, special designs incorporating anti-extrusion rings can be made, to suit piston (suffix NEO) at the Polypac ref.

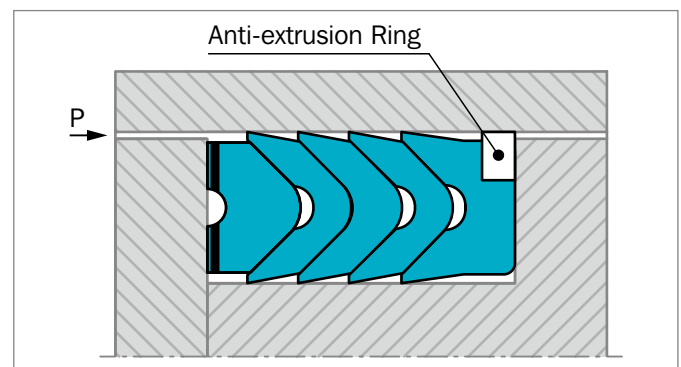

Figure 157: Veepac design with anti-extrusion ring



ADVANTAGES

- Exceptional wear resistance
- Pre-load adjustment capability
- Excellent behaviour in harsh conditions
- Rod-seal replacement without complete cylinder dismantling possible
- Long service life

APPLICATION EXAMPLES

VEEPAC seals are recommended for single acting or double acting (back to back installation) hydraulic cylinders in the following applications:

- Ship hydraulics
- Excavators
- Steel mills
- Presses

OPERATING CONDITIONS

Pressure:	Up to 40 MPa
Velocity:	Up to 0.5 m/s
Temperature:	-30 °C to +200 °C
Media:	Hydraulic fluids Mineral Oil based hydraulic fluids, Water/oil and Water/Glycol emulsions
Groove type:	Open

IMPORTANT NOTE

The above data are maximum values and cannot be used at the same time, e.g. the maximum operating speed depends on material type, pressure, temperature and gap value. Temperature range also depends on media.

GAP DIMENSIONS

To prevent extrusion the diameter not facing the pressure must be max. 0.3 mm smaller (than the piston seal) and 0.3 mm larger (than the rod seal). Using Veepac with Back-up Ring enables double values.

MATERIALS

Components of the VEEPAC seals are made in different combinations of materials, according to the specific application (see table below).

Table 140: Material Selection

Material Set Code	Temperature	Sealing Ring Material	Energizer Ring Material	
N000C	-30 to +130 °C	Cotton reinforced NBR	POM-GL-BK Cotton reinforced NBR	up to 300 mm I.D. over 300 mm I.D.
V000A	-20 to +150 °C	Aramid Fiber reinforced FKM	POM-GL-BK Aramid Fiber reinforced FKM	up to 300 mm I.D. over 300 mm I.D.
VOPOA	-20 to +200 °C	Aramid Fiber reinforced FKM	Filled PTFE Aramid Fiber reinforced FKM	up to 300 mm I.D. over 300 mm I.D.

Highlighted material is standard.



■ Installation Recommendation, Type POLYPAC® CH/NEO (with Back-up Ring)

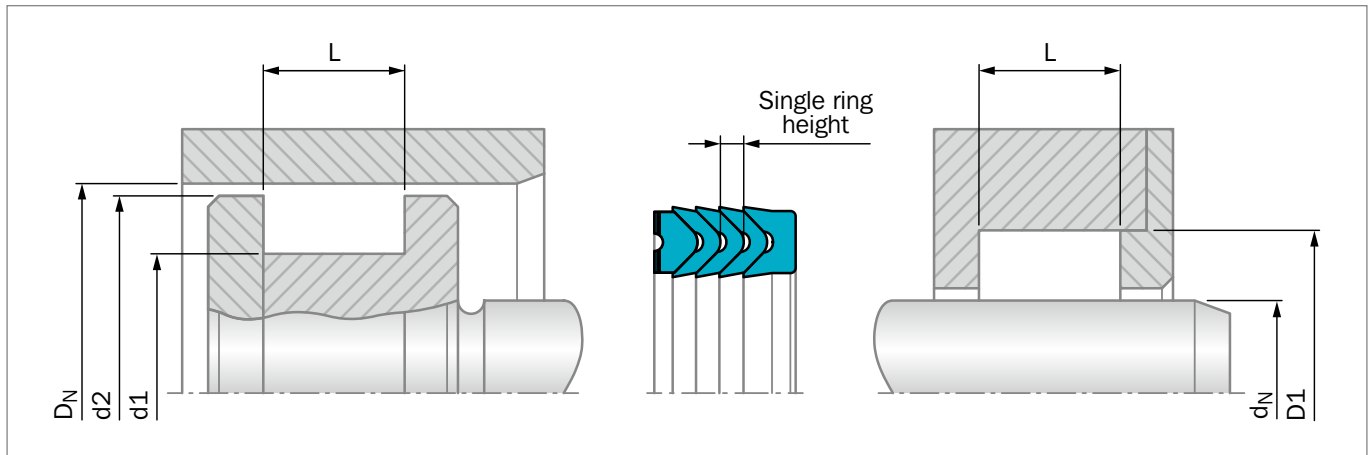

Figure 158: Installation Drawing

ORDERING EXAMPLE

For a **piston** application of standard Veepac sealing element composed by: Support ring **with anti-extrusion ring**, 3 elements vee-rings and Energizer ring:

Bore Diameter: $D_N = 150.0$ mm

Groove Diameter: $d1 = 120.0$ mm

TSS Part No.: PCH0E1500

Material Set-Code: N000C

Polypac Part. No.: CH 590472/NEO

TSS Article No. **PCH0 E 1500 - N000C**

TSS Series No. ————

Type (Standard) ————

Bore Diameter x 10 ————

Quality Index ————

Material Set-Code ————

Table 141: Installation Dimensions / TSS Part No.

Bore Diameter	Groove Diameter	Groove Width	Diameter	Single Ring Height	Special Version	TSS Part No.	Polypac Ref. No.*
D_N	$d1$	L	$d2$				
H9/f8	h11	-0.25	+/-0.1				
80.00	60.00	32.15	79.00	5.66		PCH1E0800	CH 314236/NEO
88.90	69.85	35.50	87.90	4.83		PCH0E0889	CH 350275/1/NEO
90.00	70.00	30.00	89.00	5.08		PCH0E0900	CH 354275/NEO
95.25	76.20	28.97	94.20	5.16		PCH0E0952	CH 375300/NEO
95.25	82.55	21.72	94.20	3.71	# ^	PCH1E0952	CH 375325/NEO
101.60	85.72	26.75	100.60	4.14	^	PCH0E1016	CH 400337/NEO
107.95	88.90	31.00	106.90	4.90	^	PCH0E1079	CH 425350/NEO
114.30	88.90	35.32	113.30	6.55	^	PCH0E1143	CH 450350/NEO
114.30	95.25	25.40	113.30	5.00	^	PCH1E1143	CH 450375/NEO
114.30	98.42	26.59	113.30	4.34	^	PCH2E1143	CH 450387/NEO



Bore Diameter	Groove Diameter	Groove Width	Diameter	Single Ring Height	Special Version	TSS Part No.	Polypac Ref. No.*
D _N H9/f8	d1 h11	L -0.25	d2 +/-0.1				
125.00	100.00	36.90	124.00	6.60	# ^	PCH1E1250	CH 492393/NEO
125.00	105.00	27.00	124.00	5.00	^	PCH2E1250	CH 492413/1/NEO
127.00	101.60	32.15	126.00	5.82	#	PCH0E1270	CH 500400/NEO
127.00	107.95	30.00	126.00	4.52	^	PCH1E1270	CH 500425/NEO
139.70	114.30	33.50	138.70	5.56	^	PCH0E1397	CH 550450/1/NEO
140.00	115.00	37.12	139.00	6.00	^	PCH0E1400	CH 551452/NEO
140.00	120.00	30.00	139.00	5.36		PCH1E1400	CH 551472/NEO
150.00	120.00	44.00	149.00	7.50		PCH0E1500	CH 590472/NEO
152.40	127.00	38.63	151.40	6.48		PCH0E1524	CH 600500/NEO
160.00	130.00	41.50	159.00	5.50	#	PCH1E1600	CH 629511/NEO
160.00	130.00	43.50	159.00	5.50	#	PCH2E1600	CH 629511/1/NEO
187.32	171.45	24.20	186.30	4.09	# ^	PCH0E1873	CH 737675/NEO
210.00	180.00	32.97	209.00	5.99		PCH0E2100	CH 826708/B/NEO
222.25	190.50	50.00	221.20	7.57	^	PCH0E2222	CH 875750/NEO
280.00	250.00	32.97	279.00	5.99	^	PCH0E2800	CH 1102984/B/NEO

* As the Polypac Ref. No. does not refer to the material, please always state the full number if available for identification.
 "#" and "^" see Table 142.

Table 142: Explanation to "Special Version"

Not available with rubber V-ring		^	
Available upon request	#		

POLYPAC® Veepac CH/G1



Single-acting

Chevron Ring

With Support and Pressure
Energizing Ring

Material:

POM, PTFE, Fabric Reinforced Rubber



! This page is intentionally left blank.



■ Veepac CH/G1



■ Description

Veepac G1 is a set of fabric reinforced rings comprising one support ring, one sealing ring and a pressure energizing ring. It is a single acting piston seal.

The support ring or base ring is manufactured out of nitrile elastomer with high Shore A hardness and reinforced with impregnated cotton fabric layers for an optimal extrusion resistance.

The intermediate ring - the sealing ring - is a fabric reinforced nitrile elastomer with good resilience characteristics enabling the radial deflection under pressure load. Consequently the optimum sealing force is applied to the bore to be sealed.

The energiser or spreader ring is made of POM or PTFE. Its function is to ensure a uniform pre-load of the seal.

In some specific applications the energiser ring is made out of Acetal resin or Phenolic resin. Please contact our local TSS company for further details.

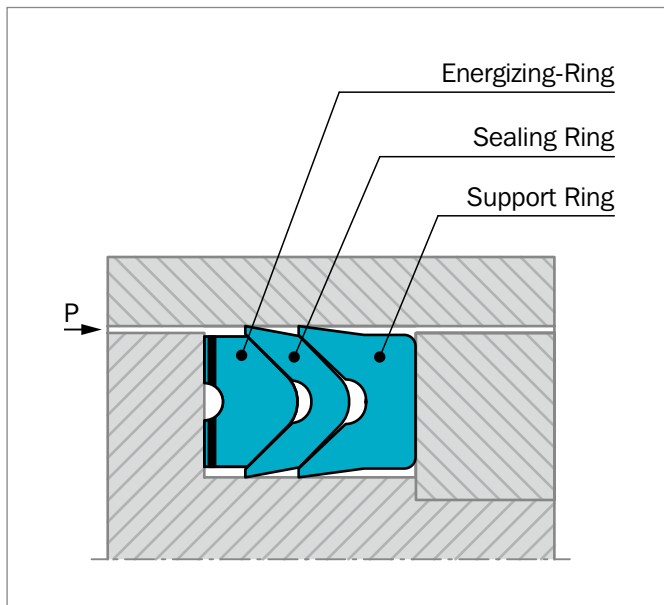

Figure 159: Veepac CH/G1

ADVANTAGES

- Exceptional wear resistance
- Pre-load adjustment capability
- Excellent behavior in harsh conditions

APPLICATION EXAMPLES

The Veepac seal is recommended for single acting or double acting (back to back installation) pistons in following applications:

- Mining equipment
- Excavator cylinders
- Steel mill cylinders
- Presses

OPERATING CONDITIONS

Pressure:	Up to 40 MPa
Velocity:	Up to 0.5 m/s
Temperature:	-30 °C to +200 °C, depending on material
Media:	Mineral oil, water glycol, water emulsions

IMPORTANT NOTE

The above data are maximum values and cannot be used at the same time, e.g. the maximum operating speed depends on material type, pressure, temperature and gap value. Temperature range also depends on media.

MATERIALS

The following material can be delivered:

Material Set Code	Temperature	Sealing Ring Material	Energizer/ Spreader Ring Material
N000C	-30 to +130 °C	Cotton reinforced NBR	POM
V000A	-20 to +150 °C	Aramid fiber reinforced FKM	POM
V0P0A	-20 to +200 °C	Aramid fiber reinforced FKM	PTFE

 Highlighted material is standard.



■ Installation Recommendation, Type CH/G1

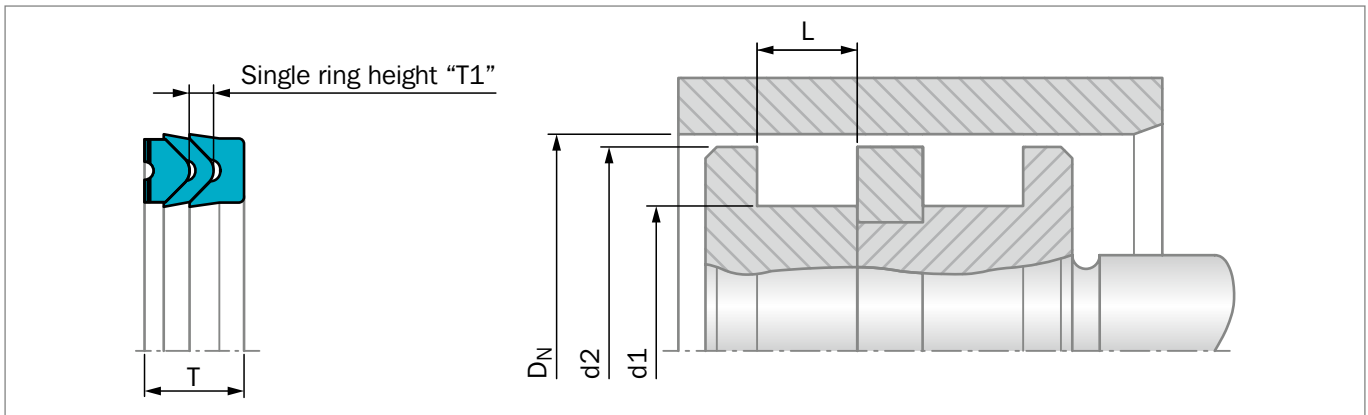

Figure 160: Installation Drawing

ORDERING EXAMPLE

For sealing element Veepac CH/G1 comprising 1 base ring and 1 Chevron element in cotton fabric reinforced NBR and the Spreader ring in POM.

Bore Diameter:	$D_N = 80.0$ mm
TSS Part No.:	PCH0G0800 from Table 143
Material Set-Code:	N000C

TSS Article No. **PCH0 G 0800 - N000C**

TSS Series No. _____

Execution Mark _____

Bore diameter x 10 _____

Quality Index (Standard) _____

Material code _____

Polypac Ref. No.: CH 314236/G1

Table 143: Installation Dimensions / TSS Part No.

Bore Diameter		Groove Diameter	Groove Width	Piston Diameter	Seal Width	Single Ring Height	TSS Part No.	Description
D_N	Tol.	d1 h11	L +0.3	d2 -0.3	T	T1		
40.0	H9/f8	25.0	11.5	39.0	11.0	3.2	PCH0G0400	CH 157098/G1
50.0	H9/f8	35.0	11.5	49.0	11.0	3.5	PCH0G0500	CH 196137/G1
55.0	H9/f8	40.0	11.5	54.0	11.0	2.9	PCH0G0550	CH 216157/G1
63.0	H9/f8	48.0	13.0	62.0	12.5	3.7	PCH0G0630	CH 248188/G1
65.0	H9/f8	50.0	11.5	64.0	11.0	3.9	PCH0G0650	CH 255196/G1
80.0	H9/f8	60.0	15.2	79.0	14.6	5.1	PCH0G0800	CH 314236/G1
100.0	H8/f8	80.0	21.2	99.0	20.6	5.0	PCH0G1000	CH 393314/G1
125.0	H8/f7	100.0	25.8	124.0	25.0	6.1	PCH0G1250	CH 492393/G1
140.0	H8/f7	115.0	25.8	139.0	25.0	8.0	PCH0G1400	CH 551452/G1
160.0	H8/f7	130.0	29.0	158.5	28.0	6.0	PCH0G1600	CH 629511/G1
180.0	H8/f7	150.0	31.5	178.5	30.5	9.9	PCH0G1800	CH 708590/G1
200.0	H8/f7	170.0	33.5	198.5	32.5	7.4	PCH0G2000	CH 787669/G1
240.0	H8/f7	210.0	33.5	238.5	32.5	10.2	PCH0G2400	CH 944826/G1
250.0	H8/f7	220.0	33.5	248.5	32.5	10.2	PCH0G2500	CH 984866/G1

POLYPAC® - Selemaster DSM

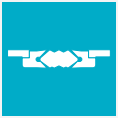

Double-acting

Compact Piston Seal

Material:

NBR + Fiber Reinforced NBR + POM

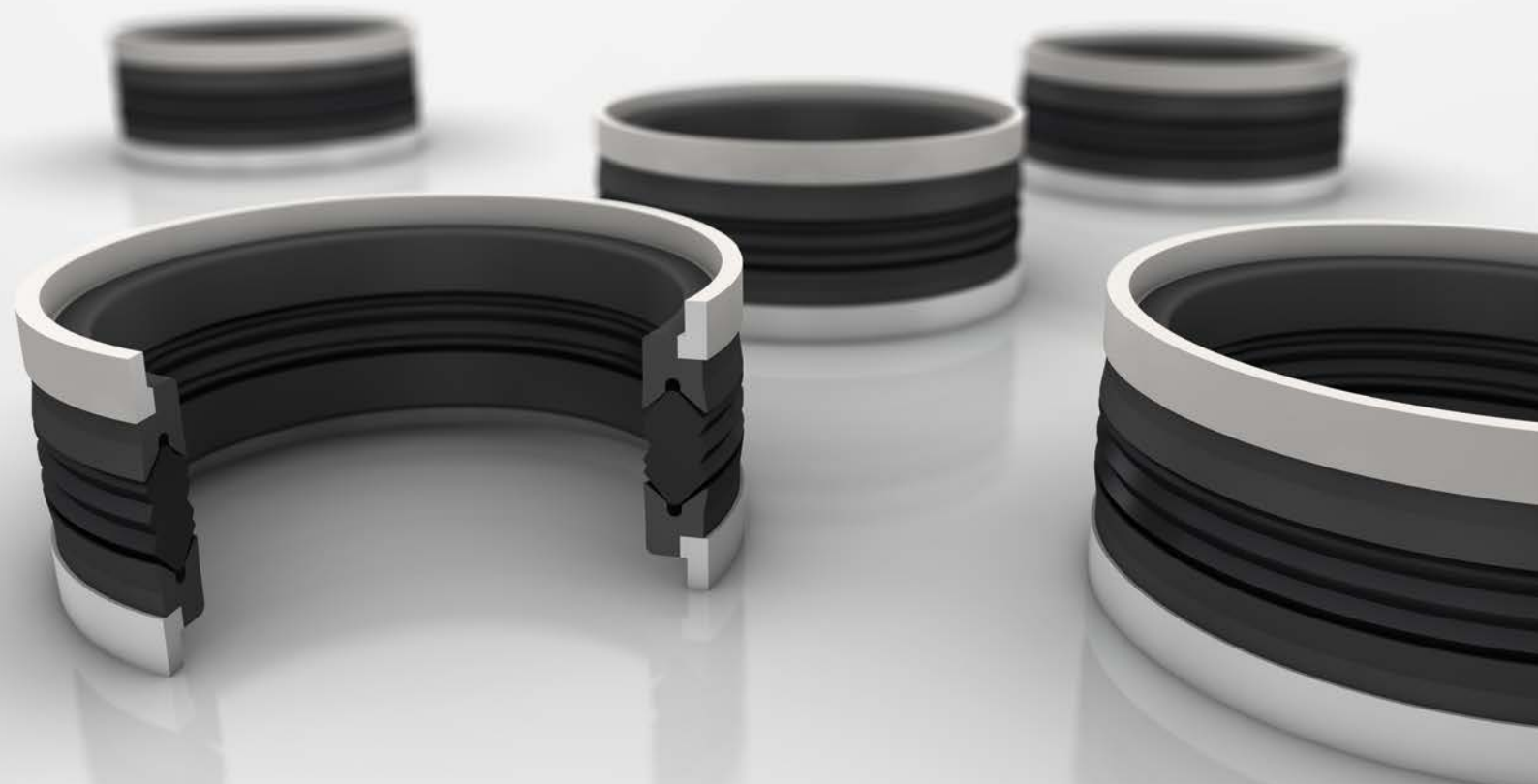

! This page is intentionally left blank.



Selemaster DSM



Description

The piston seal DSM range has been designed to meet the needs of hydraulic equipments operating at high pressures and subjected to severe loading and vibration conditions.

The main sealing element is manufactured in a highly compression set resistant nitrile. The most important quality of this element is the design of the multiple sealing lips for maximum sealing efficiency and end face configuration, which ensures that the selemaster can tolerate vibrations and severe misalignment.

The two support rings are made in cotton fabric reinforced nitrile elastomer; the "U" shape is energised when pressure is applied.

The last elements are the two guide rings manufactured in acetal resin which have also the function of anti-extrusion rings.

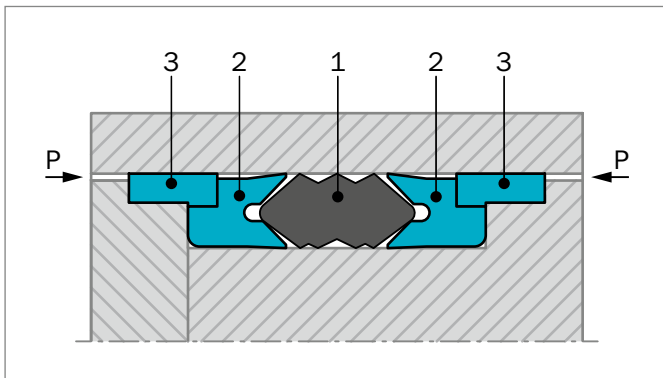

Figure 161: Selemaster design

- 1) Sealing element
- 2) Support ring
- 3) Guide ring

ADVANTAGES

- Effective sealing during vibration and shock loading
- High sealing efficiency
- Extrusion resistance at high pressure

APPLICATION EXAMPLES

- Earth-moving machines
- Excavators
- Lift platforms

OPERATING CONDITIONS

Pressure:	Up to 70 MPa
Velocity:	Up to 0.5 m/s
Temperature:	-30 °C to +130 °C
Media:	Hydraulic fluids Mineral oil-based hydraulic fluids, water and water/glycol emulsions
Groove type:	Open

IMPORTANT NOTE

The above data are maximum values and cannot be used at the same time, e.g. the maximum operating speed depends on material type, pressure, temperature and gap value. Temperature range also depends on media.

STANDARD MATERIAL

- | | |
|--------------------|-----------------------|
| 1) Sealing element | NBR 80 |
| 2) Support ring | Cotton reinforced NBR |
| 3) Guide ring | POM |

Installation Recommendation

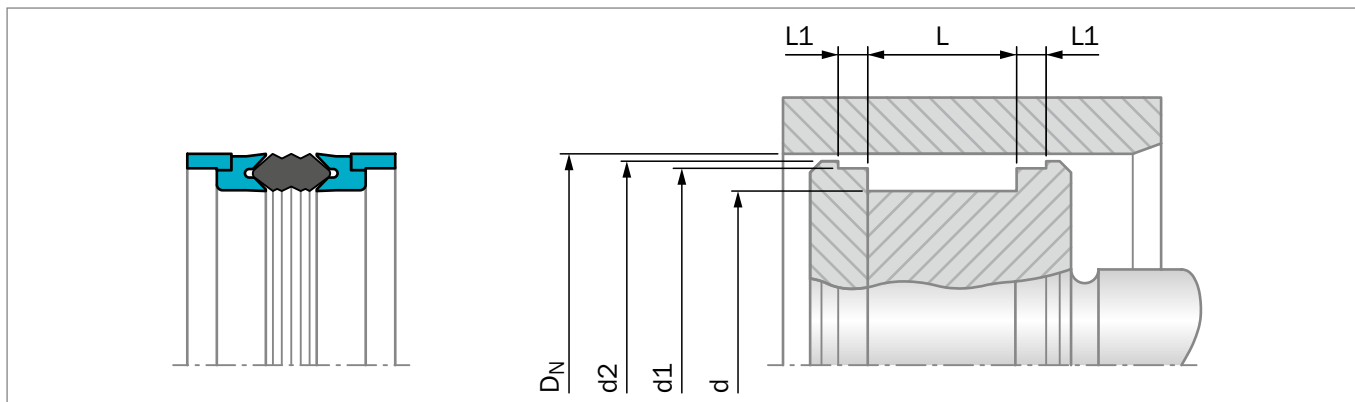

Figure 162: Installation Drawing

ORDERING EXAMPLE

Selemaster DSM

Bore Diameter:	$D_N = 70.0$ mm
Groove Diameter:	$d = 50.0$ mm
Groove Width	$E = 35.0$ mm
TSS Part No.:	PCK000700 from Table 144
Material Code:	N8CO
Polypac Ref.:	DSM 275196/1A

TSS Article No.	PCK 0 00700 - N8CO
TSS Series No.	PCK
Type (Standard)	0
Bore Diameter x 10	00700
Quality Index (Standard)	-
Material Set-Code	N8CO

Table 144: Installation Dimensions / TSS Part No.

Bore Diameter	Groove Diameter	Groove Width	Groove Width	Diameter	Diameter		TSS Part No.	Description
D_N	d	L	$L1$	$d1$	$d2$			
H11	h11	+0.2	+0.1	+/-0.05	+/-0.07			
45.00	29.00	32.00	6.35	38.80	42.80	^	PCK000450	DSM 177114/1A
50.00	34.00	32.00	6.35	43.77	47.80		PCK000500	DSM 196133/1A
55.00	40.00	32.00	6.35	48.77	52.80		PCK000550	DSM 216157/1A
60.00	44.00	32.00	6.35	53.80	57.80		PCK000600	DSM 236173/1A
63.00	47.00	32.00	6.35	56.74	60.80		PCK000630	DSM 248185/1A
63.50	47.62	31.75	6.35	57.25	61.30	^	PCK000635	DSM 250187/1A
65.00	49.00	32.00	6.35	58.70	62.80		PCK000650	DSM 255192/1A
70.00	50.00	35.00	9.52	62.62	67.50		PCK000700	DSM 275196/1A
75.00	55.00	35.00	9.52	67.70	72.50		PCK000750	DSM 295216/1A
80.00	60.00	35.00	9.52	72.62	77.50		PCK000800	DSM 314236/1A
80.00	64.00	32.00	9.52	72.62	77.50		PCK100800	DSM 314251/1A
85.00	65.00	35.00	9.52	77.62	82.50		PCK000850	DSM 334255/1A
90.00	70.00	35.00	9.52	82.58	87.80		PCK000900	DSM 354275/1A
90.00	74.00	32.00	9.52	82.87	87.80		PCK100900	DSM 354291/1A
92.07	73.02	34.92	9.52	84.66	89.60	^	PCK000921	DSM 362287/1A
95.00	75.00	35.00	9.52	87.60	92.50		PCK000950	DSM 374295/1A



Bore Diameter	Groove Diameter	Groove Width	Groove Width	Diameter	Diameter		TSS Part No.	Description
D _N	d	L	L1	d1	d2			
H11	h11	+0.2	+0.1	+/-0.05	+/-0.07			
95.25	76.20	34.92	9.52	87.86	92.80	^	PCK000953	DSM 375300/1A
100.00	80.00	35.00	9.52	92.60	97.50		PCK001000	DSM 393314/1A
101.60	82.55	34.92	9.52	94.20	99.10		PCK001016	DSM 400325/1A
105.00	85.00	35.00	9.52	97.60	102.50	^	PCK001050	DSM 413334/1A
110.00	85.00	45.00	12.70	101.82	107.30		PCK001100	DSM 433334/1A
110.00	90.00	35.00	9.52	102.70	107.50		PCK101100	DSM 433354/1A
114.30	88.90	44.45	12.70	106.12	111.60		PCK001143	DSM 450350/1A
115.00	90.00	45.00	12.70	106.82	112.30		PCK001150	DSM 452354/1A
120.00	95.00	45.00	12.70	111.82	117.30		PCK001200	DSM 472374/1A
120.00	100.00	35.00	9.52	112.80	117.50		PCK101200	DSM 472393/1A
125.00	100.00	45.00	12.70	116.82	122.30		PCK001250	DSM 492393/1A
127.00	101.60	44.45	12.70	118.80	124.30		PCK001270	DSM 500400/1A
130.00	105.00	45.00	12.70	121.82	127.30		PCK001300	DSM 511413/1A
130.00	110.00	35.00	9.52	122.70	127.30		PCK101300	DSM 511433/1A
135.00	110.00	45.00	12.70	126.82	132.30		PCK001350	DSM 531433/1A
139.70	114.30	44.45	12.70	131.47	137.00	^	PCK001397	DSM 550450/1A
140.00	115.00	45.00	12.70	131.72	137.30		PCK001400	DSM 551452/1A
140.00	120.00	35.00	9.52	132.70	137.30		PCK101400	DSM 551472/1A
145.00	120.00	45.00	12.70	136.72	142.30		PCK001450	DSM 570472/1A
150.00	125.00	45.00	12.70	141.72	147.30		PCK001500	DSM 590492/1A
152.40	127.00	44.45	12.70	144.15	149.70	^	PCK001524	DSM 600500/1A
160.00	135.00	45.00	12.70	151.72	157.10		PCK001600	DSM 629531/1A
165.00	135.00	45.00	12.70	158.00	162.10		PCK001650	DSM 649531/1A
170.00	140.00	45.00	12.70	163.00	167.90		PCK001700	DSM 669551/1A
177.80	152.40	44.45	12.70	169.55	175.10		PCK001778	DSM 700600/1A
180.00	155.00	45.00	12.70	171.60	177.10		PCK001800	DSM 708610/1A
185.00	160.00	45.00	12.70	176.72	182.10		PCK001850	DSM 728629/1A
190.00	165.00	45.00	12.70	181.72	187.10		PCK001900	DSM 748649/1A
200.00	175.00	45.00	12.70	191.72	197.10		PCK002000	DSM 787688/1A
210.00	185.00	45.00	12.70	201.60	207.10		PCK002100	DSM 826728/1A
220.00	195.00	45.00	12.70	211.60	217.10		PCK002200	DSM 866767/1A
230.00	205.00	45.00	12.70	221.72	227.10		PCK002300	DSM 905807/1A
240.00	215.00	45.00	12.70	231.72	237.10		PCK002400	DSM 944846/1A
250.00	225.00	45.00	12.70	241.72	247.10		PCK002500	DSM 984886/1A
260.00	235.00	45.00	12.70	251.72	257.10		PCK002600	DSM 1024925/1A
270.00	245.00	45.00	12.70	261.72	267.10		PCK002700	DSM 1062965/1A
280.00	255.00	45.00	12.70	271.72	277.10		PCK002800	DSM 11021004/1A
290.00	265.00	45.00	12.70	281.72	287.10		PCK002900	DSM 11411043/1A
300.00	275.00	45.00	12.70	291.72	297.10		PCK003000	DSM 11811082/1A
360.00	335.00	44.50	12.70	351.76	357.30		PCK003600	DSM 14171318/1A

^ Available upon request

! This page is intentionally left blank.

Additional Seals



Available upon Request

Old Series

Special Series



! This page is intentionally left blank.



TURCON® VARISEAL® W

Single-acting piston seal energized by a slantcoil spring. Its main advantage lies in its low friction and constant preloading force over a relatively large deformation range.

The Turcon® Variseal® W is used wherever friction has to be kept within a narrow tolerance zone.

Diameter Range mm	Pressure Range MPa	Temperature Range °C	Velocity m/s
8 - 2,500	Up to 40	-70 to +260	Up to 15

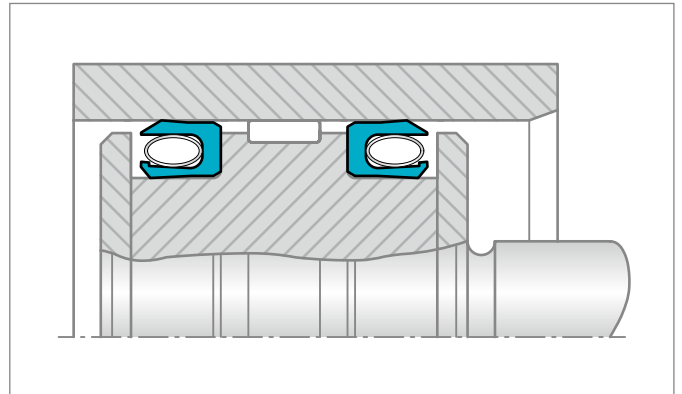

TURCON® VARISEAL® M2 CR

Single-acting sealing element comprising a U-shaped Turcon® ring and a stainless steel energizing V-spring. Low friction with no stick-slip, minimal break out force and high wear resistance. Resistant to most liquids and chemicals. Unlimited shelf life.

With integrated back up rings in Zurcon® Z43 for higher pressures or larger gaps.

Diameter Range mm	Pressure Range MPa	Temperature Range °C	Velocity m/s
8 - 330	Up to 100	-45 to +260	Up to 5

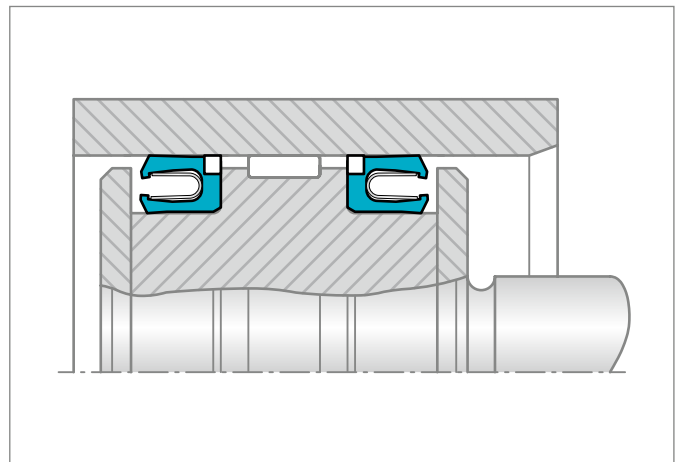

TURCON® GLYD RING® CR

Double-acting O-Ring energized piston seal with one or two corner reinforcements for dynamic applications. Installed in closed grooves, including grooves to ISO 7425-1, as piston Turcon® Glyd Ring®. Low friction with no stick-slip, minimal break out force and high wear resistance with integrated Back-up Rings for higher pressures or larger gaps. Standard TSS Article Numbers are available (PGR).

Diameter Range mm	Pressure Range MPa	Temperature Range °C	Velocity m/s
20 - 2,700	Up to 100	-45 to +200	Up to 5

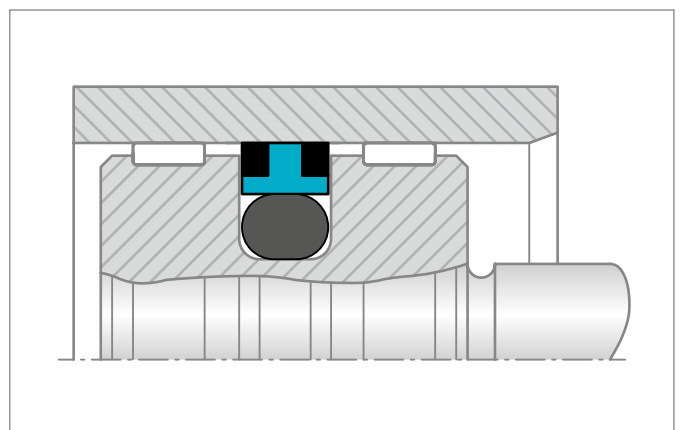



TURCON® CAPTIVE GLYD RING®

A double-acting seal recommended for linear applications. It is designed to pass over holes/ports in the counter surface or to slide across mating surfaces that have dimensional changes from a small diameter with sealing function over the seal to a large diameter with no sealing function or vice versa. Split hardware is required and prevents the seal from pulling out the groove while passing over ports or variable diameter counter parts.

Standard TSS Part Numbers are available (PGC).

Diameter Range mm	Pressure Range MPa	Temperature Range °C	Velocity m/s
6 - 2,600	Up to 60	-45 to +200	Up to 15

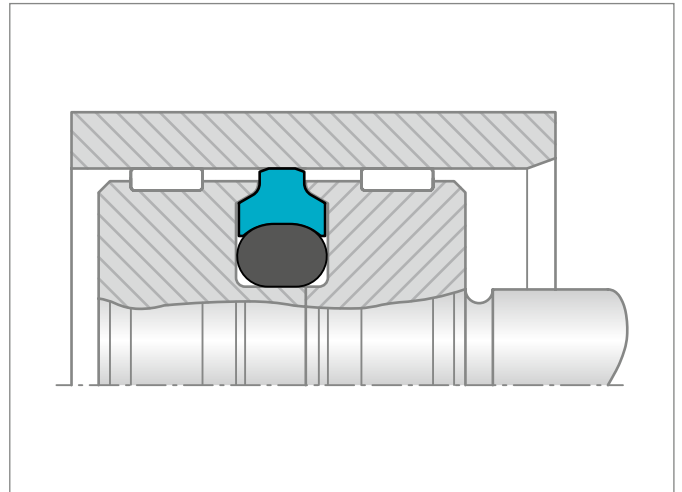

TURCON® CAPTIVE GLYD RING® WITH DOUBLE O-RING

A double-acting seal for linear applications recommended for passing over larger holes/ports in the counter surface or to slide across mating surfaces that have dimensional changes from a small diameter with sealing function over the seal to a large diameter with no sealing function or vice versa. Split hardware is required and prevents the seal from pulling out of the groove while passing over ports or variable diameter counter parts.

Diameter Range mm	Pressure Range MPa	Temperature Range °C	Velocity m/s
6 - 2,600	Up to 60	-45 to +260	Up to 15

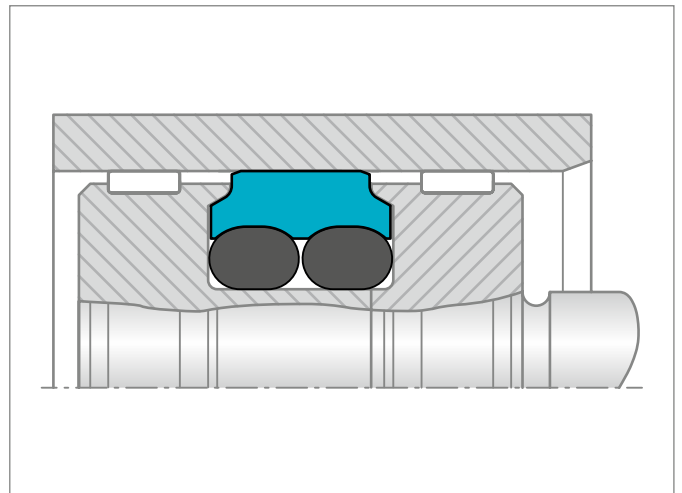

TURCON® CAPTIVE GLYD RING® CR

A double-acting corner reinforced seal for higher pressure linear applications recommended for passing over larger holes/ports in the counter surface, or to slide across mating surfaces that have dimensional changes from a small diameter with sealing function over the seal to a large diameter with no sealing function or vice versa. Split hardware is required and prevents the seal from pulling out the groove while passing over ports or variable diameter counter parts.

Diameter Range mm	Pressure Range MPa	Temperature Range °C	Velocity m/s
6 - 2,600	Up to 100	-45 to +260	Up to 15

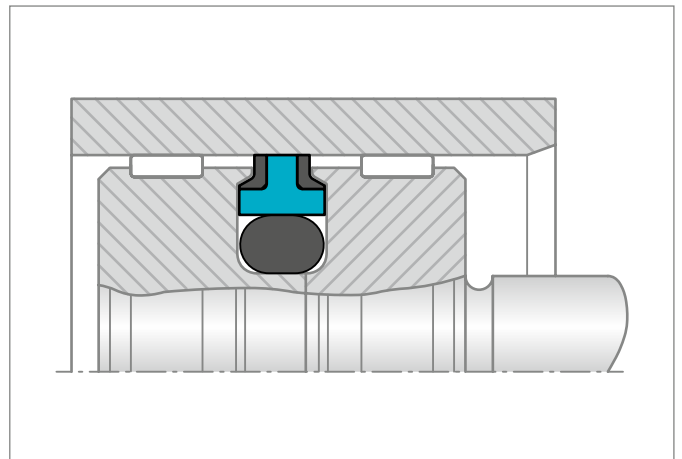



TURCON® STEPSEAL® 2A

Single-acting primary seal for applications requiring stabilized seal position in the groove. A further development on Turcon® Stepseal® 2K by adding a stabilizing edge, which prevents the seal from tilting, caused by seal-system pressure build-up between seals in tandem configuration. It also increases assembly robustness through protection of the seal face during insertion of the rod. Same high sealing properties as Stepseal® 2K. Stepseal® 2A is used as a primary seal in piston sealing systems, preferably together with a secondary seal from the range of Turcon® and Zurcon® seals.

Installation in the same grooves as Turcon® Stepseal® 2K and grooves according to ISO 7425-1.

Standard TSS Part Numbers are available (PST).

Diameter Range mm	Pressure Range MPa	Temperature Range °C	Velocity m/s
15 - 2,700	60	-45 to +200	Up to 15

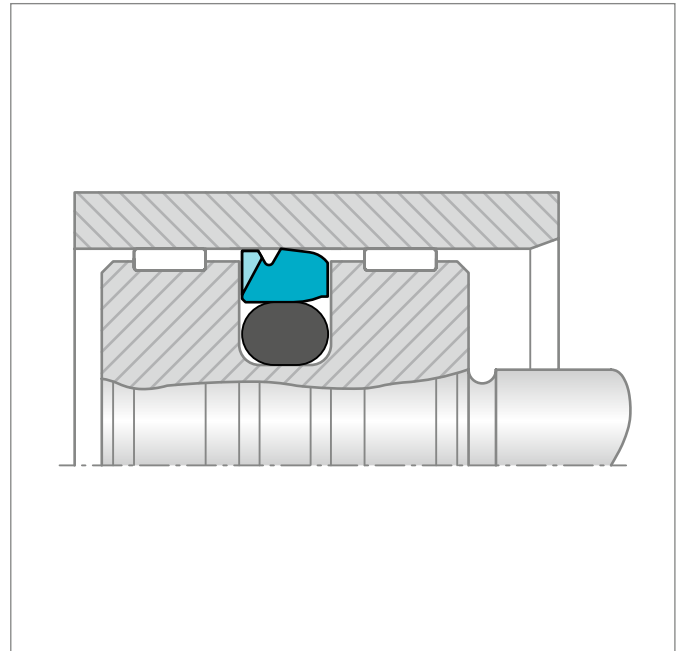

TURCON® STEPSEAL® 2A CR

Single-acting O-Ring energized piston seal with integrated Back-up Ring for higher pressure or bigger gaps for dynamic applications. High sealing efficiency, low friction with no stick-slip, minimal break-out force and high wear resistance. Installed in closed grooves including grooves acc. ISO 7425-1

Standard TSS Part Numbers are available (PSB).

Diameter Range mm	Pressure Range MPa	Temperature Range °C	Velocity m/s
15 - 2,700	100	-45 to +200	Up to 5

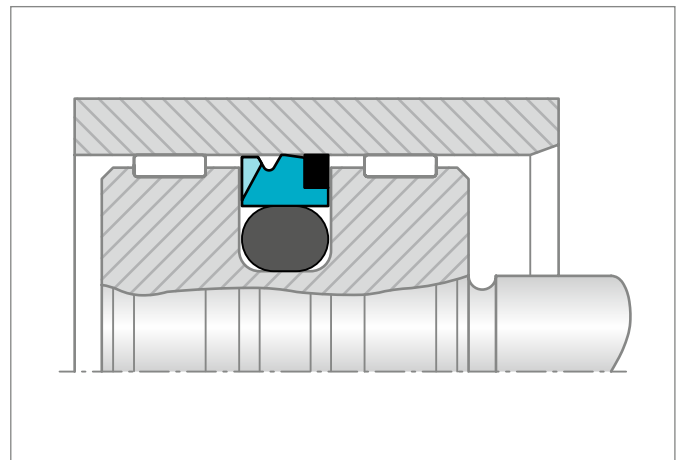



TURCON® BUFFER RING

Turcon® Buffer Ring is an uncut piston ring. With notches on one side, the ring is a single-acting seal often used as protector of a common sealing system against peak pressures, where the notch prevents risk of pressure trap. If double-acting sealing is required, it is necessary to install two buffer rings, back-to-back, to take the pressure from both sides. For linear, helical and rotary movements.

Standard TSS Part Numbers are available (PFB).

Diameter Range mm	Pressure Range MPa	Temperature Range °C	Velocity m/s
8 - 2,500	60	+5 to +160	Up to 15 (10 rotary)

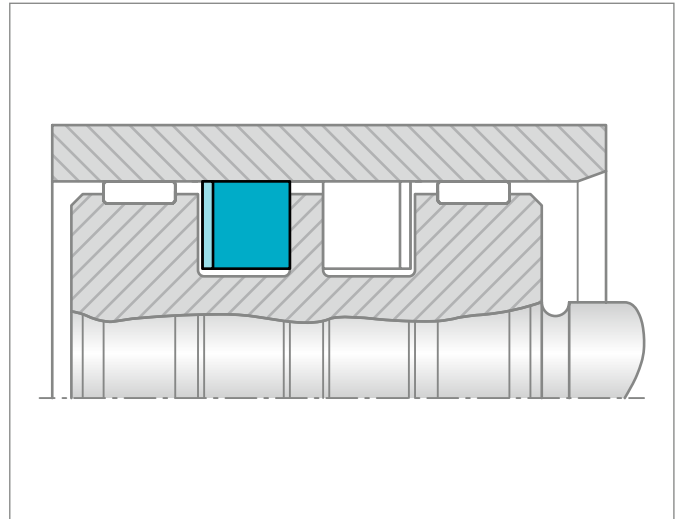

TURCON® GLYD RING® SG

Double-acting O-Ring energized piston seal for dynamic applications. Generally applied as spare part or for heavy applications requiring seals with oversized cross-sections. Installation according to ISO 7425-1 “Square Groove housings for pistons seals”. Turcon® materials provide low friction with no stick-slip, minimal break out force and high wear and pressure resistance.

Standard TSS Part Numbers are available (PGM).

Diameter Range mm	Pressure Range MPa	Temperature Range °C	Velocity m/s
10 - 2,700	Up to 60	-45 to +200	Up to 5

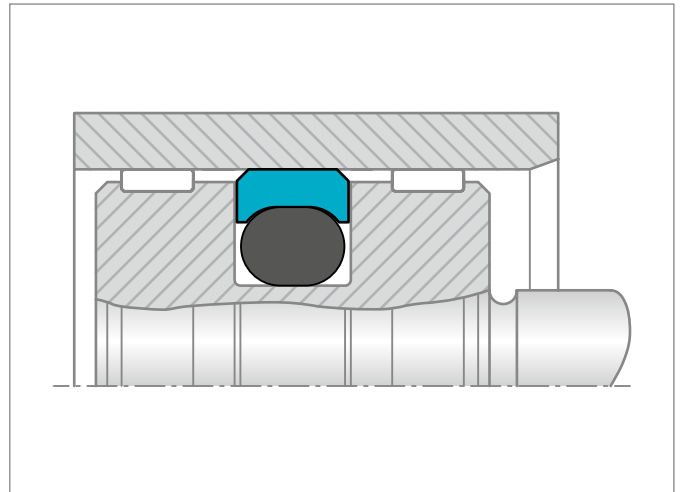

TURCON® STEPSEAL® SG

Single-acting O-Ring energized piston seal for dynamic applications. Generally applied as spare part or for heavy applications requiring seals with oversized cross-sections. Installation identical to ISO 7425-1 “Square Groove housings for pistons seals”. Turcon® materials provide low friction with no stick-slip, minimal break out force and high wear and pressure resistance.

Standard TSS Part Numbers are available (PSM).

Diameter Range mm	Pressure Range MPa	Temperature Range °C	Velocity m/s
10 - 2,700	Up to 60	-45 to +200	Up to 5

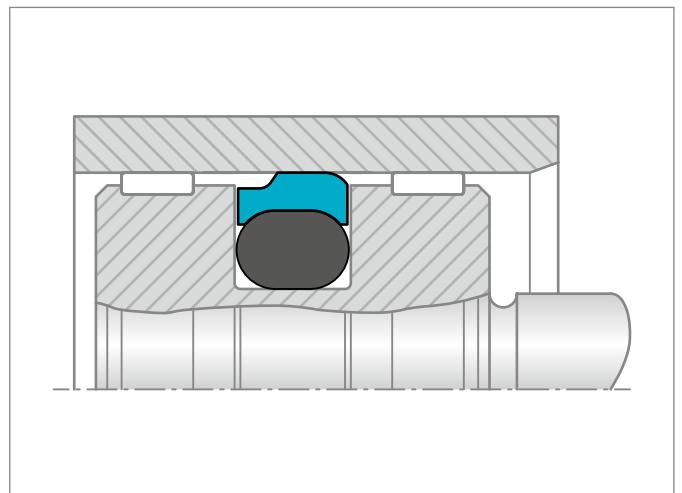



TURCON® AQ-SEAL® BEAN SEAL

A double-acting rubber energized piston seal for sealing between two media, e.g. fluid/gas separation by incorporating a narrow footprint elastomer Bean Seal into the dynamic sealing face. Recommended for piston accumulators, preferably in tandem configuration with a Turcon® Stepseal® V. Extended diameter range compared to standard AQ-Seal® at page 311.

Installation in grooves according to ISO 7425-1 (see standard Turcon® AQ-Seal®).

Standard TSS Part Numbers are available (PQB).

Diameter Range mm	Pressure Range MPa	Temperature Range °C	Velocity m/s
16 - 2,300	Up to 50	-45 to +110	Up to 2

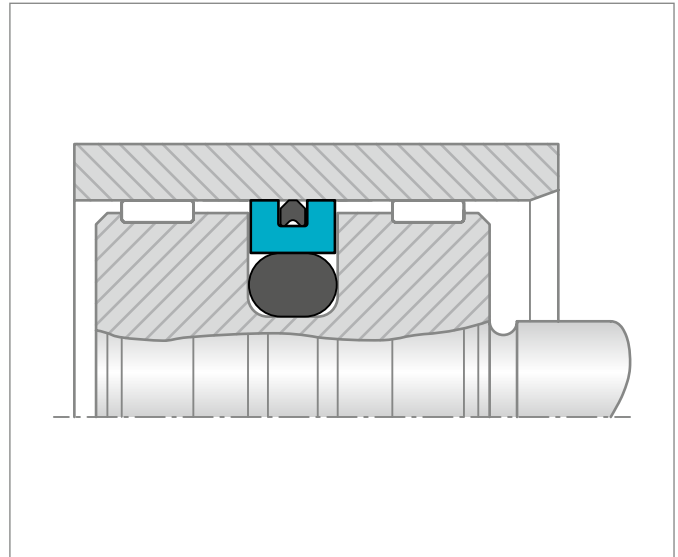

TURCON® AQ-SEAL® 5 BEAN SEAL

A double-acting rubber energized piston seal for sealing between two media, e.g. fluid/gas separation by incorporating a narrow footprint elastomer Bean Seal installed into the dynamic sealing face. Recommended for piston accumulators preferably in tandem configuration with a Turcon® Stepseal® V. Extended diameter range compared to standard AQ-Seal® 5 at page 301. Installation in the same housing groove dimensions as standard Turcon® AQ-Seal® 5.

Standard TSS Part Numbers are available (PQC).

Diameter Range mm	Pressure Range MPa	Temperature Range °C	Velocity m/s
16 - 2,300	Up to 60	-45 to +110	Up to 3

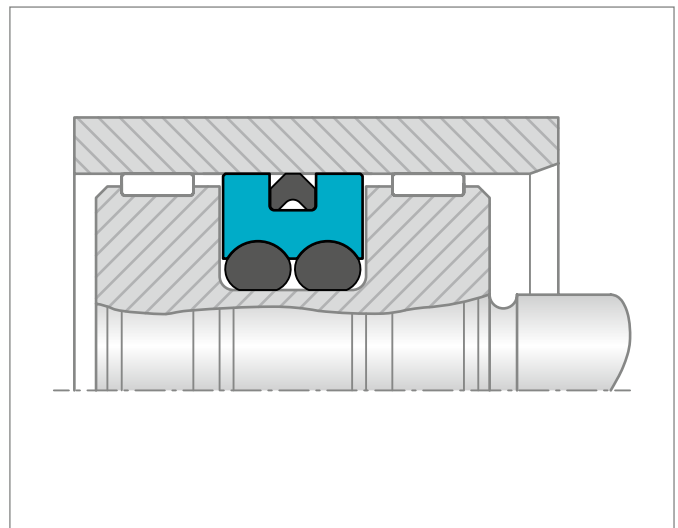

! This page is intentionally left blank.